

ν PRISM:

An Experimental Method to
Remove Neutrino Interaction
Uncertainties from Oscillation
Experiments

Mike Wilking
Stony Brook University
University of Chicago Seminar
January 12th, 2015

precision
reaction
independent
spectrum
measurement

ν PRISM:

An Experimental Method to Remove Neutrino Interaction Uncertainties from Oscillation Experiments

Mike Wilking
Stony Brook University
University of Chicago Seminar
January 12th, 2015

Overview

- Neutrino mixing and CP violation
- Test case: The T2K experiment
- Can experiments measure neutrino energy?
- Introduction to nuPRISM
- nuPRISM physics capabilities
 - ν_μ disappearance analysis
 - Sterile neutrino sensitivity and $\sigma(\nu_e)$ measurements
 - anti-neutrinos
- Feasibility (Cost and Time)
- Future outlook

Neutrino Mixing

Flavor States

Mass States

Note: $c_{ij} = \cos(\theta_{ij})$, $s_{ij} = \sin(\theta_{ij})$

$$\begin{pmatrix} \nu_e \\ \nu_\mu \\ \nu_\tau \end{pmatrix} = \begin{pmatrix} 1 & 0 & 0 \\ 0 & c_{23} & s_{23} \\ 0 & -s_{23} & c_{23} \end{pmatrix} \times \begin{pmatrix} c_{13} & 0 & s_{13}e^{-i\delta} \\ 0 & 1 & 0 \\ -s_{13}e^{i\delta} & 0 & c_{13} \end{pmatrix} \times \begin{pmatrix} c_{12} & s_{12} & 0 \\ -s_{12} & c_{12} & 0 \\ 0 & 0 & 1 \end{pmatrix} \times \begin{pmatrix} e^{i\alpha_1}/2 & 0 & 0 \\ 0 & e^{i\alpha_2}/2 & 0 \\ 0 & 0 & 1 \end{pmatrix} \times \begin{pmatrix} \nu_1 \\ \nu_2 \\ \nu_3 \end{pmatrix}$$

"Atmospheric ν "

(Super-K, K2K, MINOS)
 $\theta_{23} = 45^\circ \pm 6^\circ$ (90% C.L.)

"Reactor ν "

(Daya Bay, RENO,
 Double CHOOZ)
 $\theta_{13} = 9.0^\circ \pm 0.5^\circ$

"Solar ν "

(SNO, KamLAND)
 $\theta_{12} = 33.9^\circ \pm 1.0^\circ$

Majorana
 phases;
 Not yet
 observed

- The neutrino flavor states are related to the mass states via a mixing matrix
- Two of three mixing angles are quite large
- The remaining angle, θ_{13} , is small by comparison
- CP violation is controlled by the parameter δ

Defining “Precision δ_{CP} Measurements”

Hyper-Kamiokande

CPV Discovery Sensitivity (w/ Mass Hierarchy known)

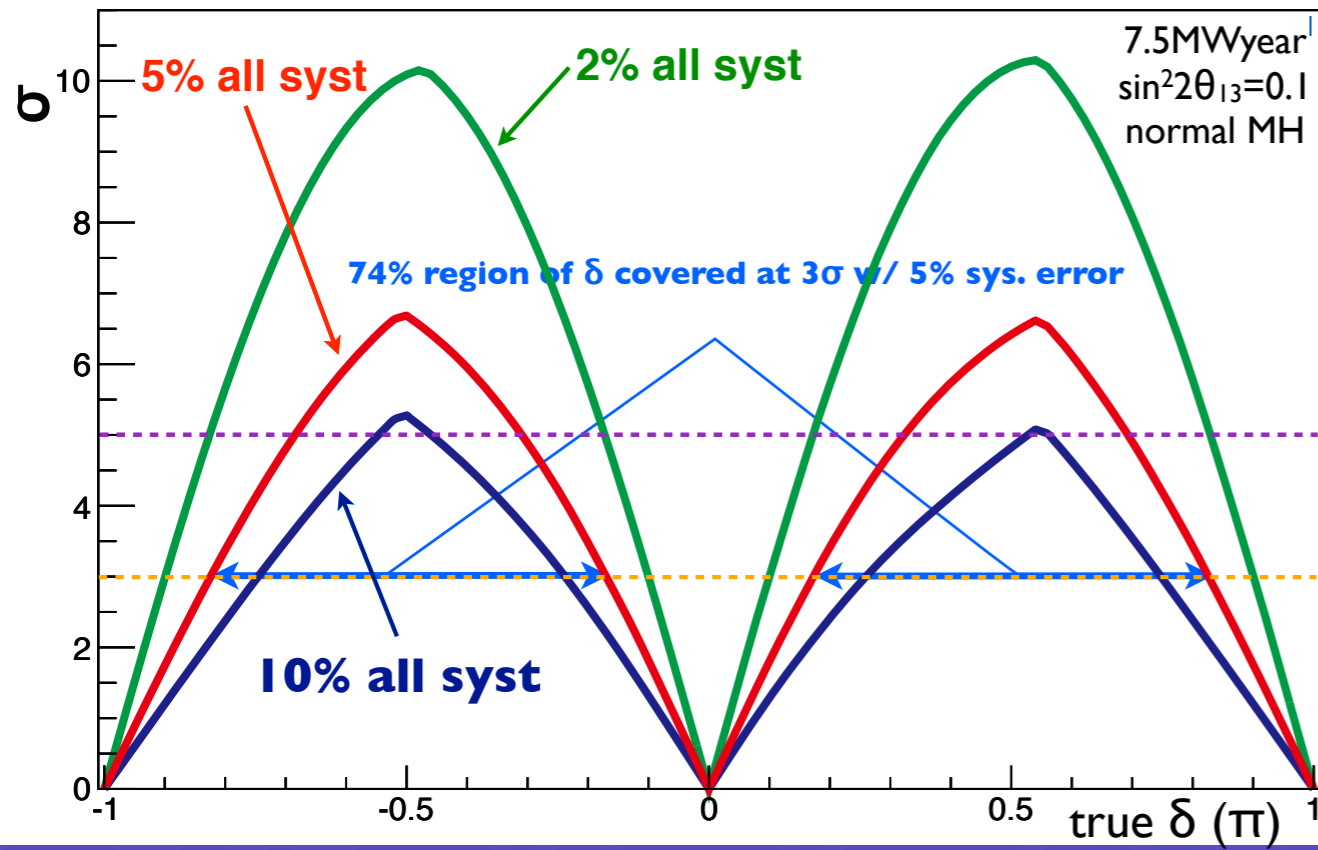

High Sensitivity to CPV w/ $\sim 5\%$ sys. error

LBNE

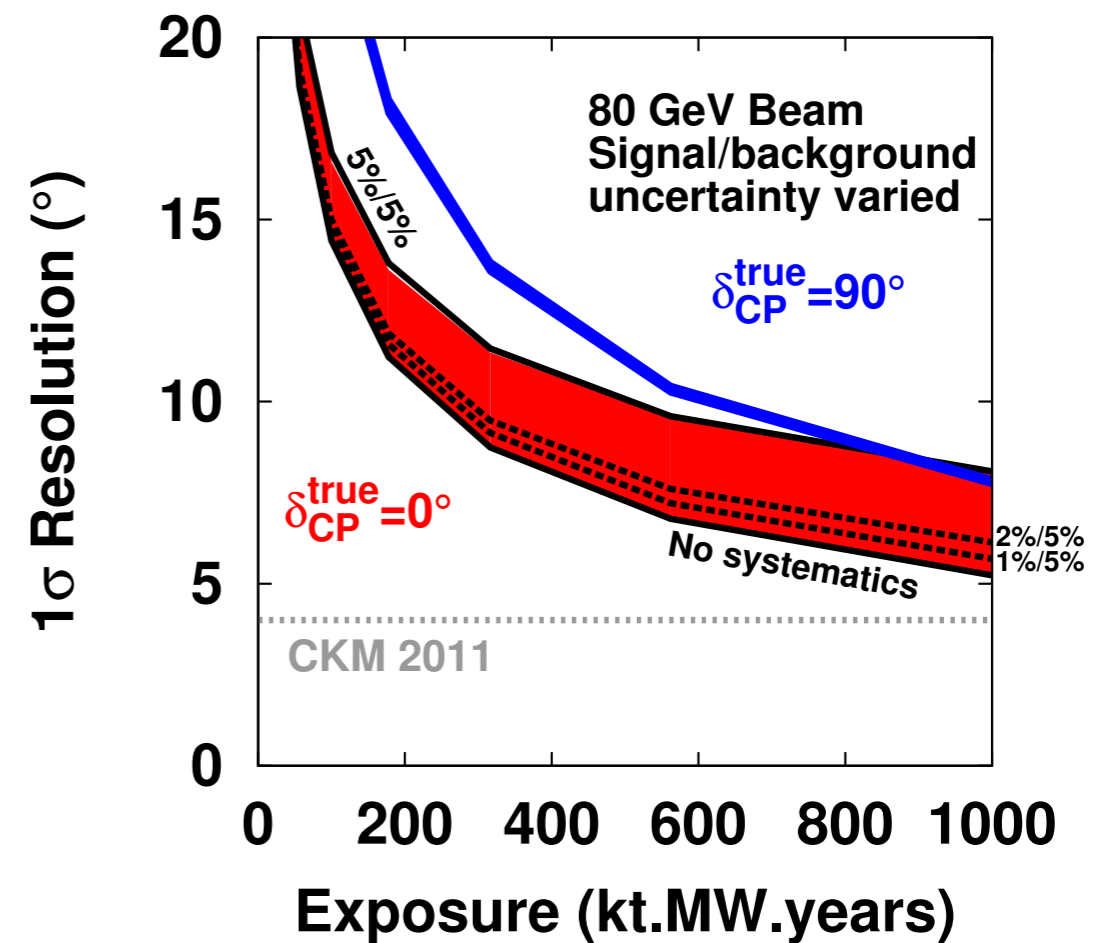

- To fully exploit the data taken by the next generation of oscillation experiments, $\sim 2\%$ systematic uncertainties are required
 - The LBNE physics mandate in the P5 report requires 1% signal uncertainty
- Neutrino energy reconstruction has a large effect on θ_{23} , which limits the sensitivity to δ_{CP}

Neutrino Interactions

(at the GeV Scale)

- Charged Current Quasi-Elastic (CCQE)
 - Neutrino flavor is tagged by outgoing lepton
 - Often the signal mode for oscillation experiments
- Charged Current Pion Production (CC π^+)
 - Comparable cross section to CCQE at 1 GeV
 - Background to CCQE-based oscillation searches

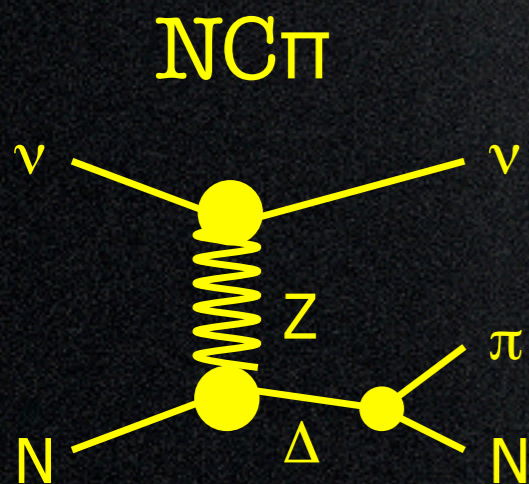
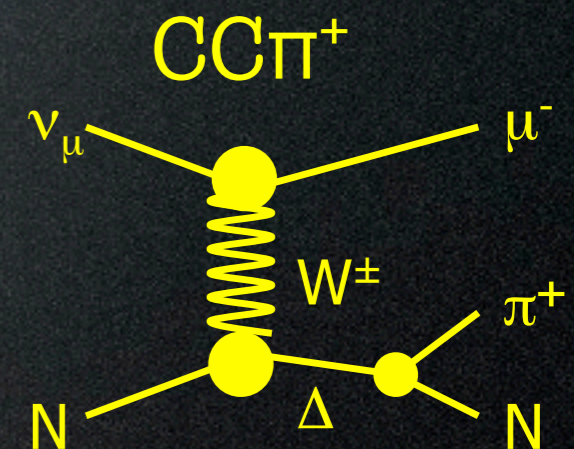
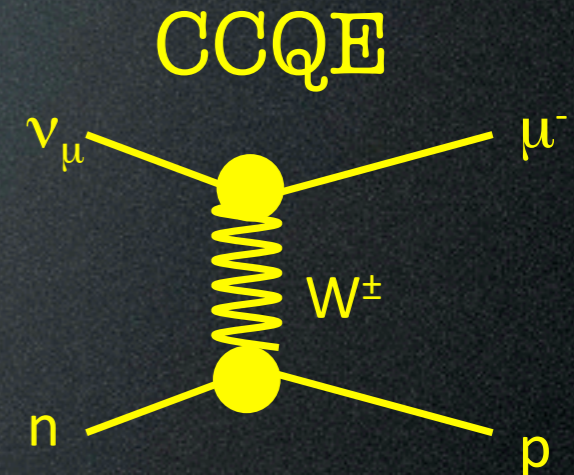

- Neutral Current Pion Production (NC π)
 - NC π^0 produces 2 photons
 - Can be misidentified as an electron
 - NC π^+ produces a single charged track
 - Can be misidentified as either a muon or electron

Test Case: The T2K Experiment

Super-K Detector

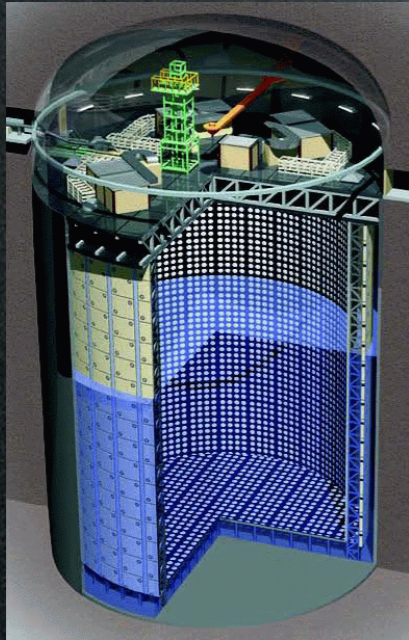

J-PARC Accelerator



Near Detector

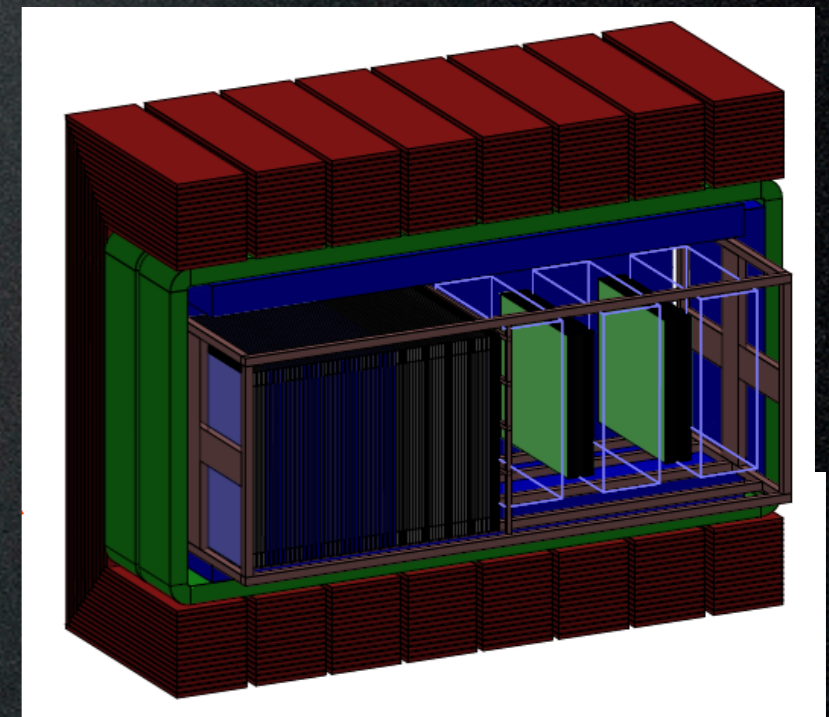

- The T2K experiment searches for neutrino oscillations in a **high purity ν_μ beam**
- A **near detector** located 280 m downstream of the target measures the **unoscillated neutrino spectrum**
- The **neutrinos travel 295 km** to the Super-Kamiokande water Cherenkov detector
 - Search for **appearance of ν_e** (to measure θ_{13} , δ_{CP})
 - Search for **disappearance of ν_μ** (to measure θ_{23} , Δm^2_{31})

Super-K Particle Identification

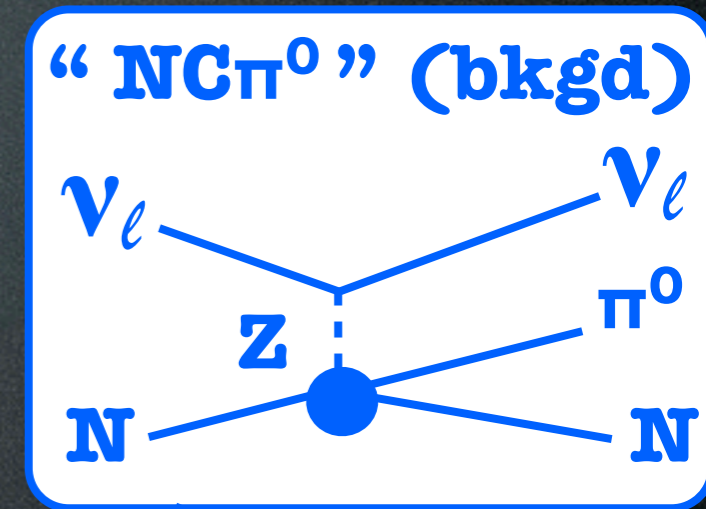
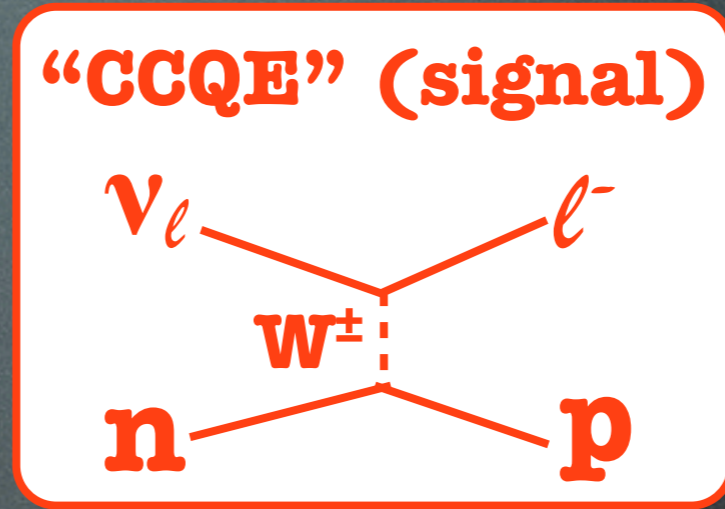
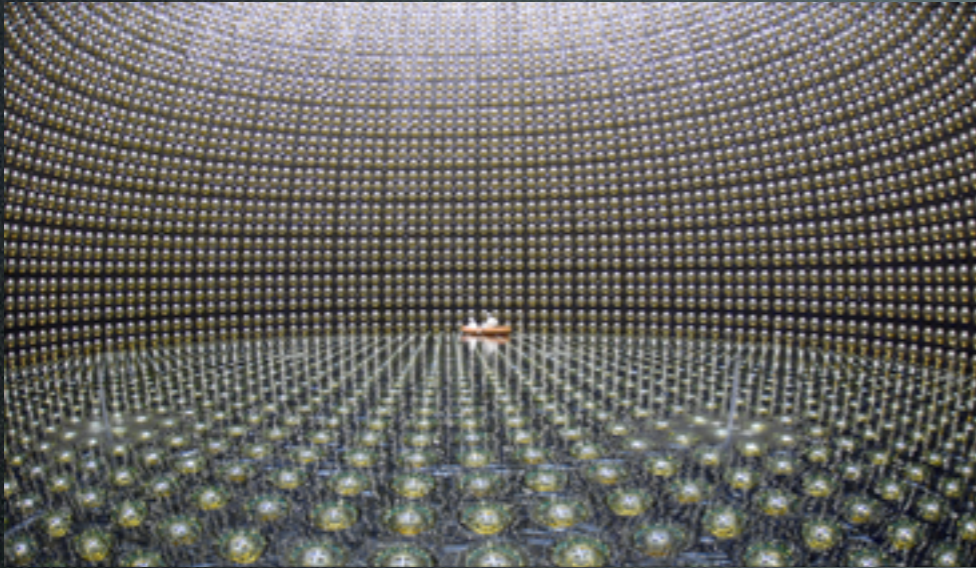

- 50 kton water Cherenkov detector
 - 39.3m diameter, 41.4m height
- $\nu_\mu \rightarrow \mu^\pm$ **detection**
 - Less scattering \Rightarrow sharp rings
- $\nu_e \rightarrow e^\pm$ **detection**
 - More scattering \Rightarrow fuzzy rings
- ν_e **background** $\rightarrow \pi^0$
 - 2 electron rings ($\pi^0 \rightarrow 2\gamma$)
 - **To separate from electrons, MUST detect 2nd ring**

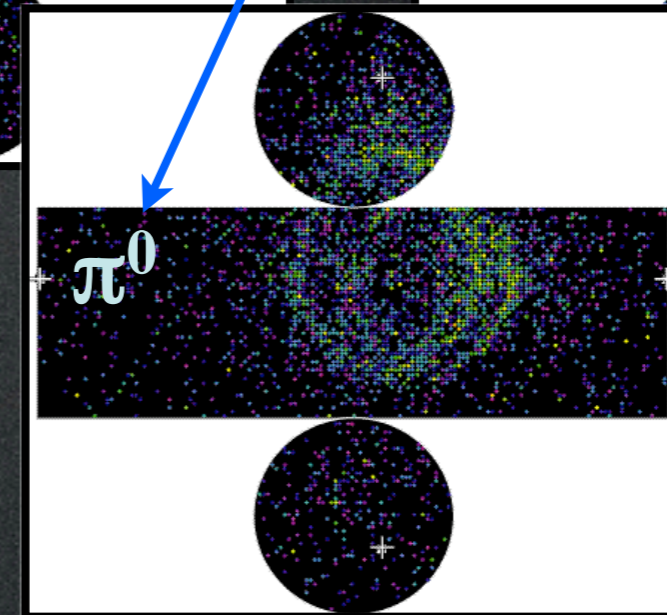
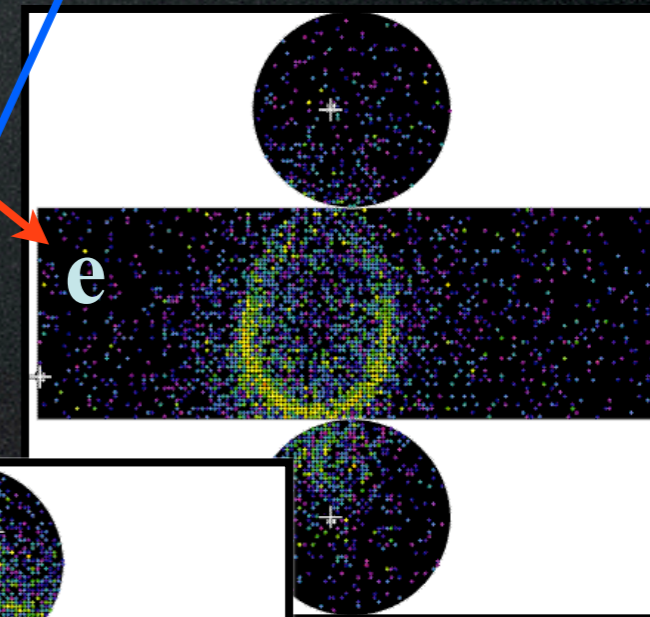
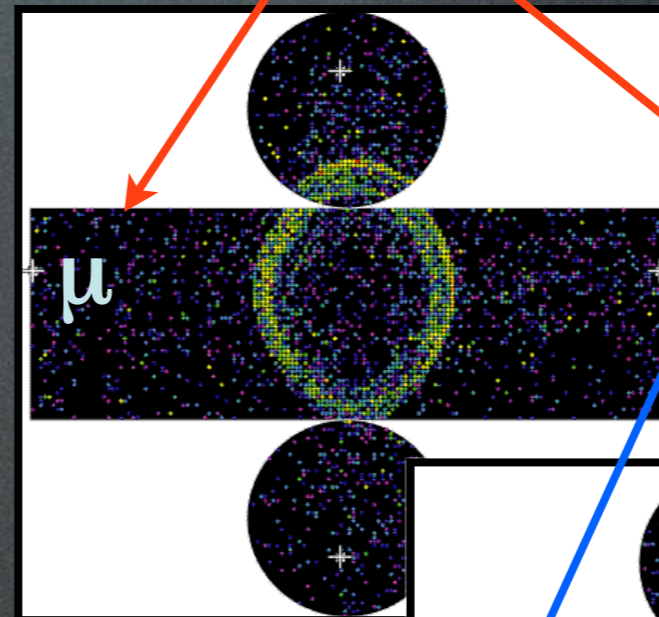

Off-Axis Neutrino Flux

- Along the beam direction, $E_\nu \propto p_\pi$
- By pointing the beam slightly off-axis, $E_\nu \approx \text{constant}$ (above some p_π)

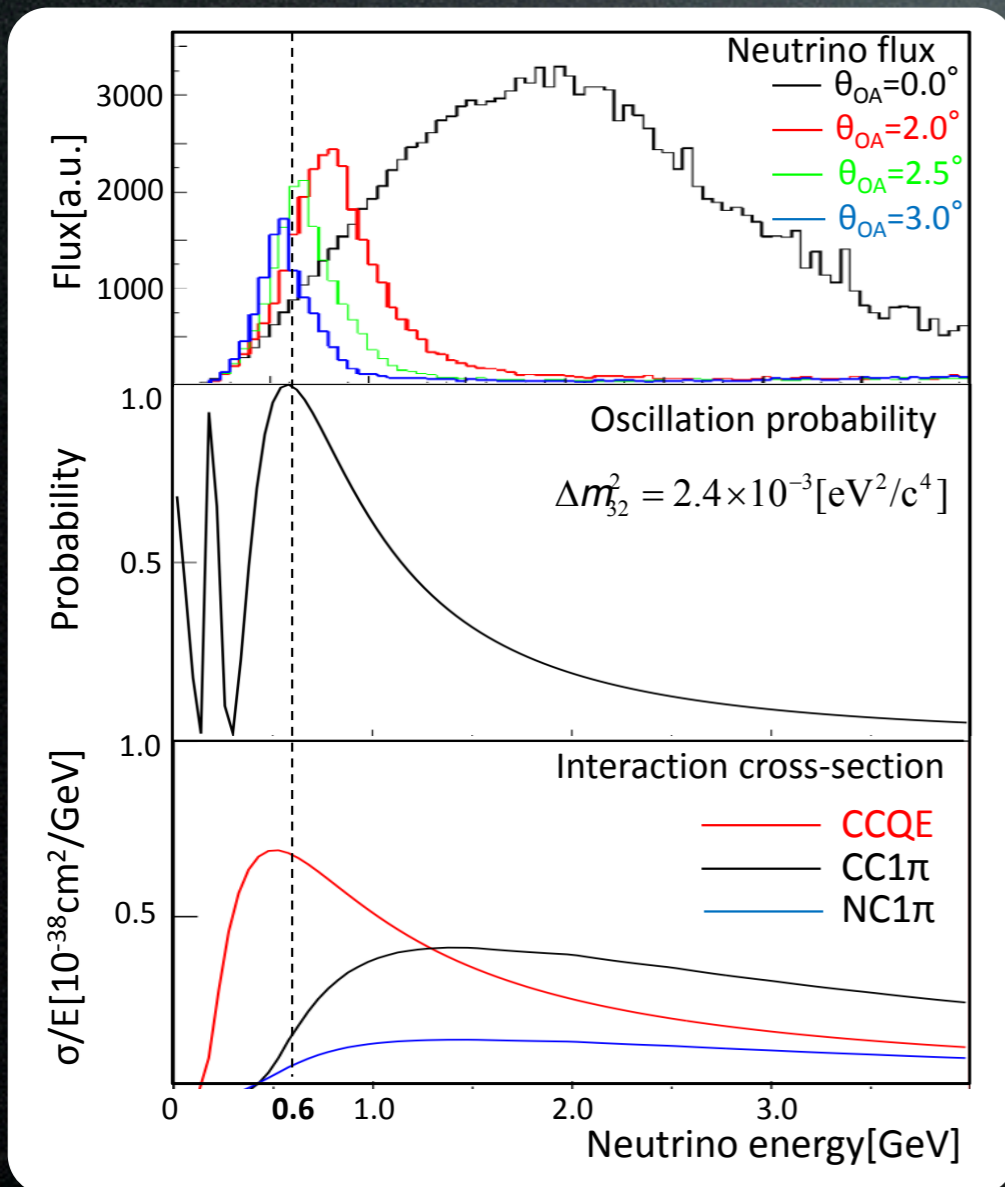
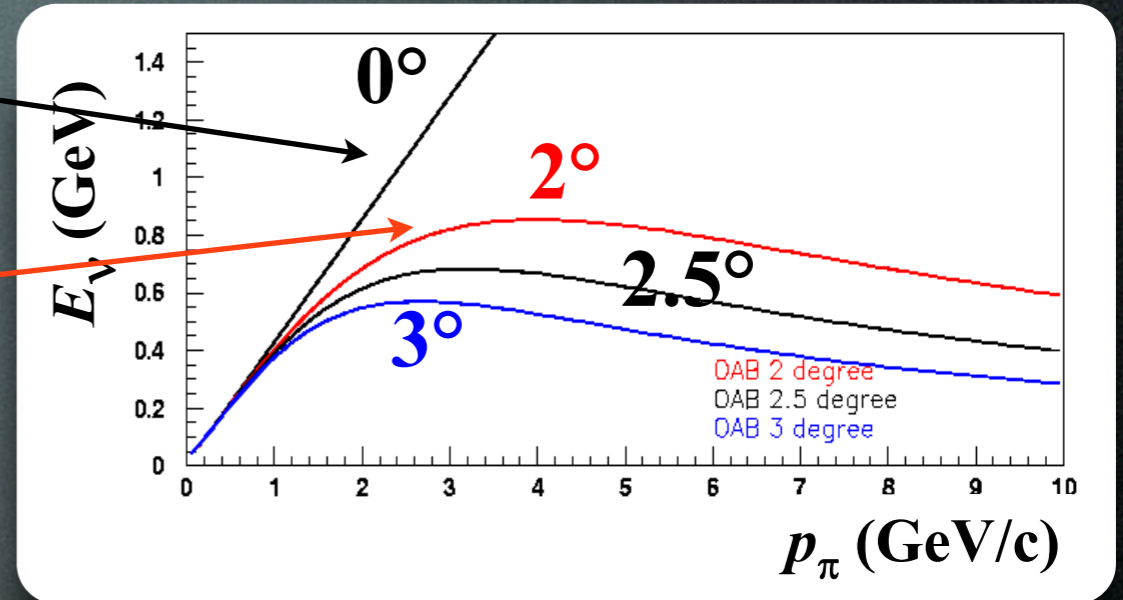

- Can **tune ν energy peak** by varying the off-axis angle
- Optimize for oscillation maximum
- Reduces the high E_ν tail
- Reduces the $\text{NC}\pi^0$ background
- Reduces the $\text{CC-multi-}\pi$ and DIS backgrounds
- **This off-axis effect is the key physics principle exploited by νPRISM**

T2K ν_μ Disappearance

Unoscillated Number of events at Super-K

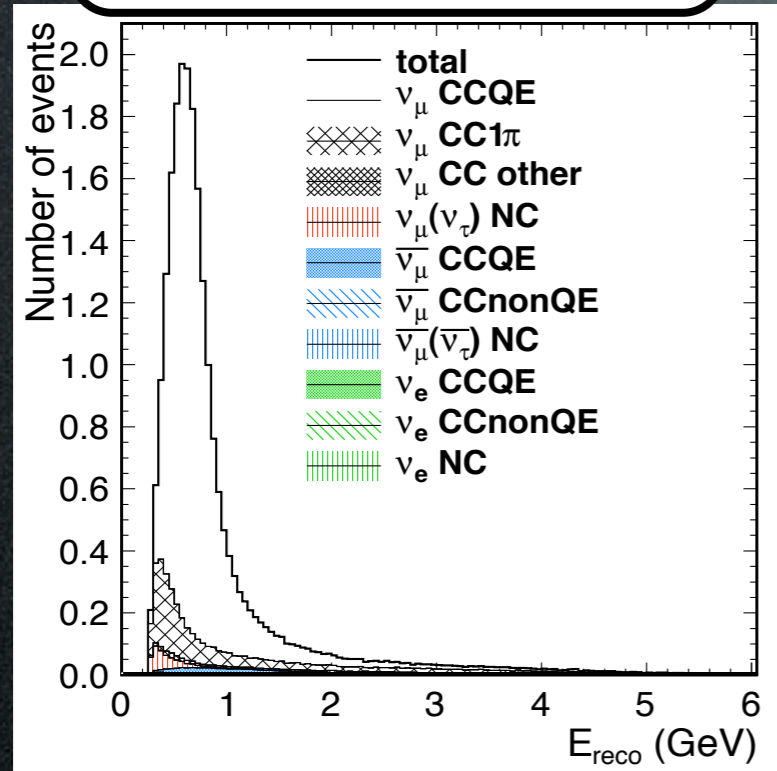

oscillation

$\sin^2(2\theta_{23})=1$
 $\Delta m_{32}^2=2.4 * 10^{-3} \text{ eV}^2/c^4$

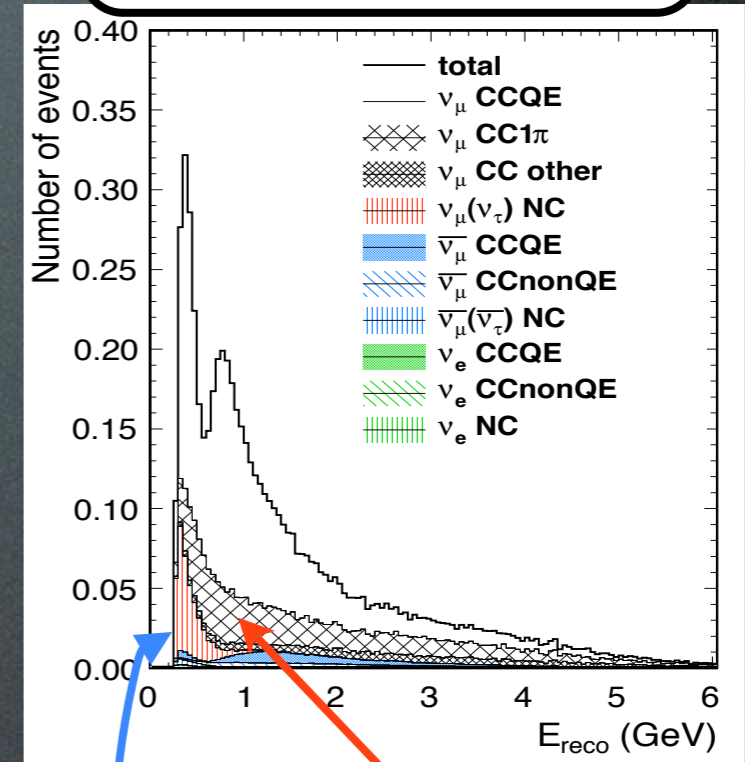

- Largest backgrounds are from $\text{CC}\pi^+$ and $\text{NC}\pi^+$
- **$\text{NC}\pi^+$** : pion is misidentified as a muon
 - **Uncertainty on $\text{NC}\pi^+$ is large (>100%)**
- **$\text{CC}\pi^+$** : pion is unobserved
 - Neutrino energy is misreconstructed
 - Fills in the oscillation “dip”
(big impact on θ_{23} measurement)

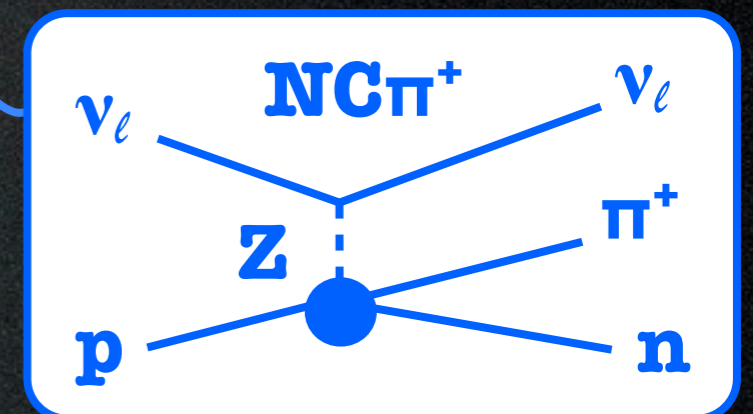
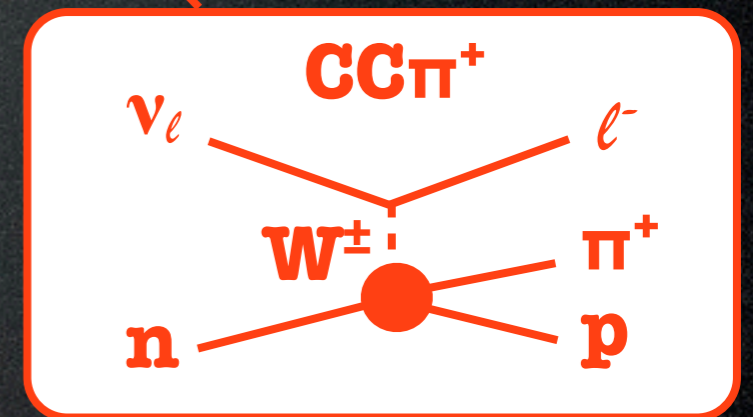

Measuring E_ν

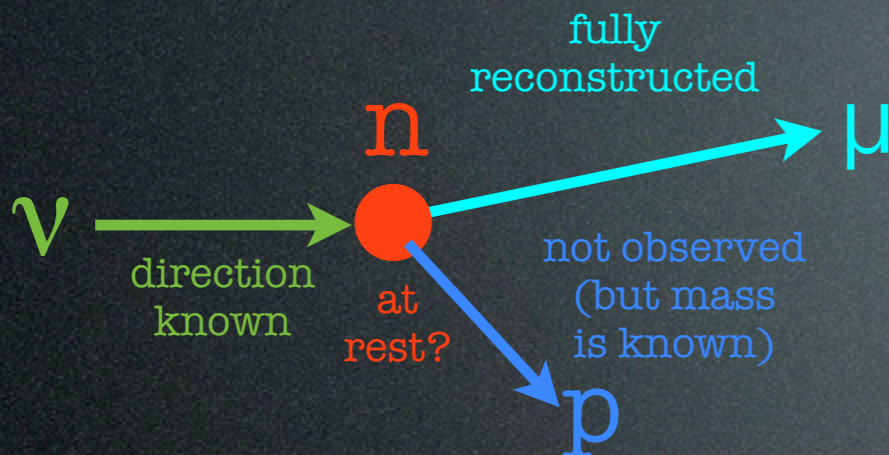

$$E_\nu^{QE} = \frac{2(M'_n)E_\mu - ((M'_n)^2 + m_\mu^2 - M_p^2)}{2 \cdot [(M'_n) - E_\mu + \sqrt{E_\mu^2 - m_\mu^2} \cos \theta_\mu]}$$

- The neutrino energy is determined from the final state particle kinematics
- If only the outgoing muon 4-momentum is measured, E_ν is determined assuming:
 - **The neutrino direction is known (good assumption)**
 - Detectors are far from the beam source
 - **The target nucleon is at rest (marginal assumption)**
 - Adds an irreducible smearing to the neutrino energy resolution
 - **The recoiling nucleon mass is known (problematic assumption)**
 - This is only correct for interactions on a single nucleon (next slide)
- Some experiments will attempt to measure the energy of the outgoing hadrons
 - **Requires knowledge of neutron production (problematic assumption)**

Can Experiments Measure E_ν ?

- In 2009, MiniBooNE CCQE data showed an excess not predicted by any existing neutrino cross section model
 - ...and inconsistent with NOMAD CCQE data at higher energies
- This is now believed to be caused by nucleon correlations (and other nuclear and even non-nuclear effects)
 - If correct, a large fraction of events ($\sim 20-30\%$) can have a significant bias in reconstructed energy
- No direct data constraint exists
 - Oscillation experiments completely rely on models that were very different just 5 years ago

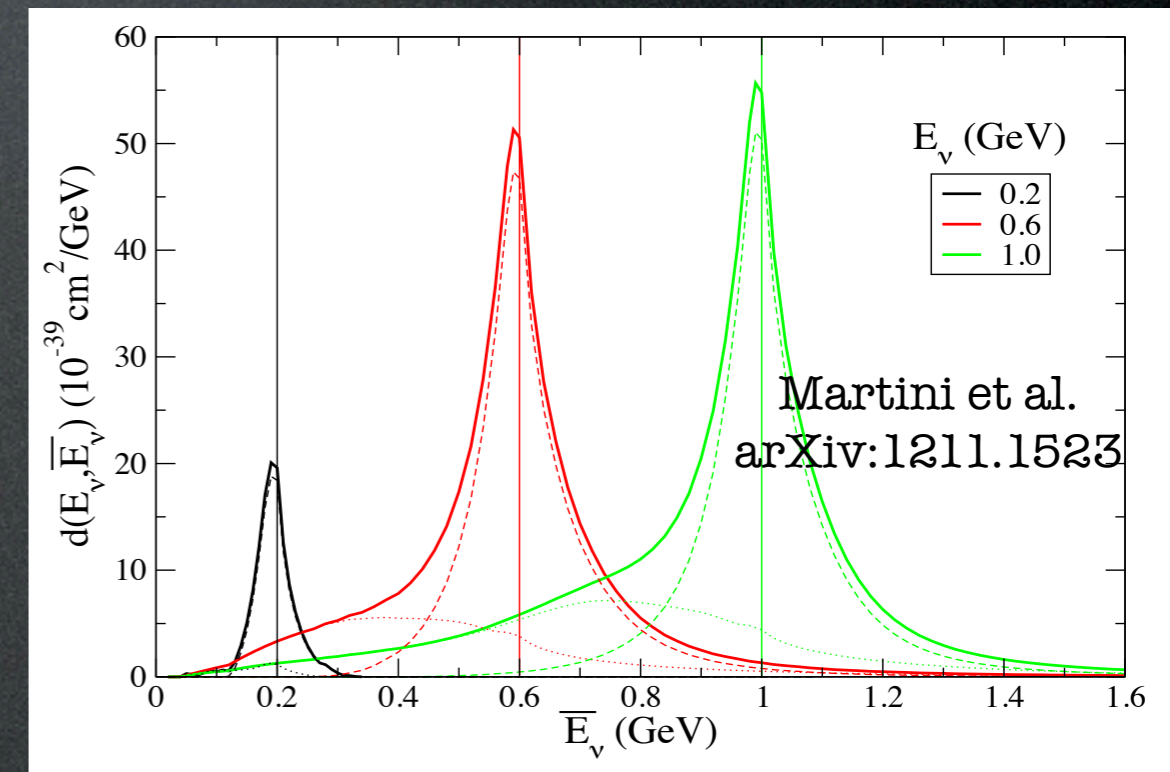
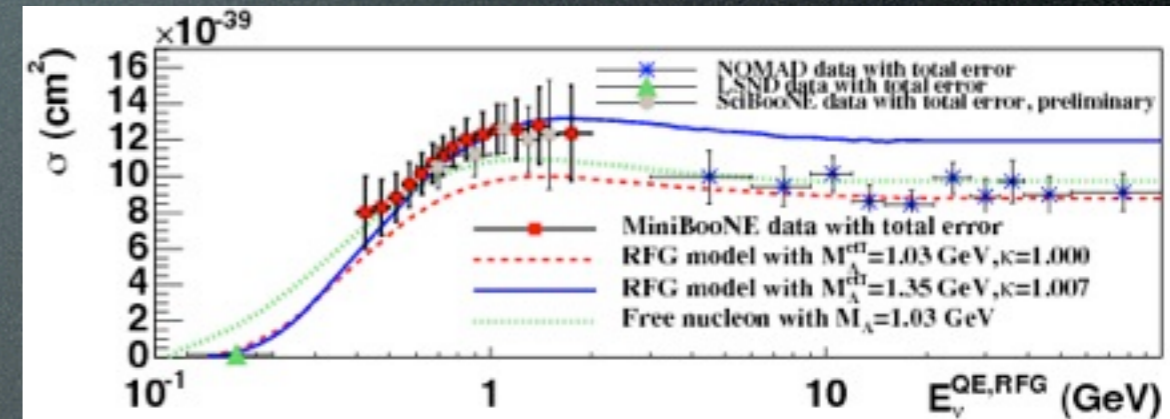

How Well are the New Models Understood?

- It is very difficult to answer this question without a direct measurement
- However, the two most commonly used “new” models can be compared
 - J. Nieves, I. Ruiz Simo, and M. J. Vicente Vacas, PRC 83:045501 (2011)
 - M. Martini, M. Ericson, G. Chanfray, and J. Marteau, PRC 80:065501 (2009)
- Cross section differs by a factor of 2 to 3 over a large range of neutrino energies
- Which model is correct?
 - Is either model correct?
- Nuclear physics at 1 GeV is difficult

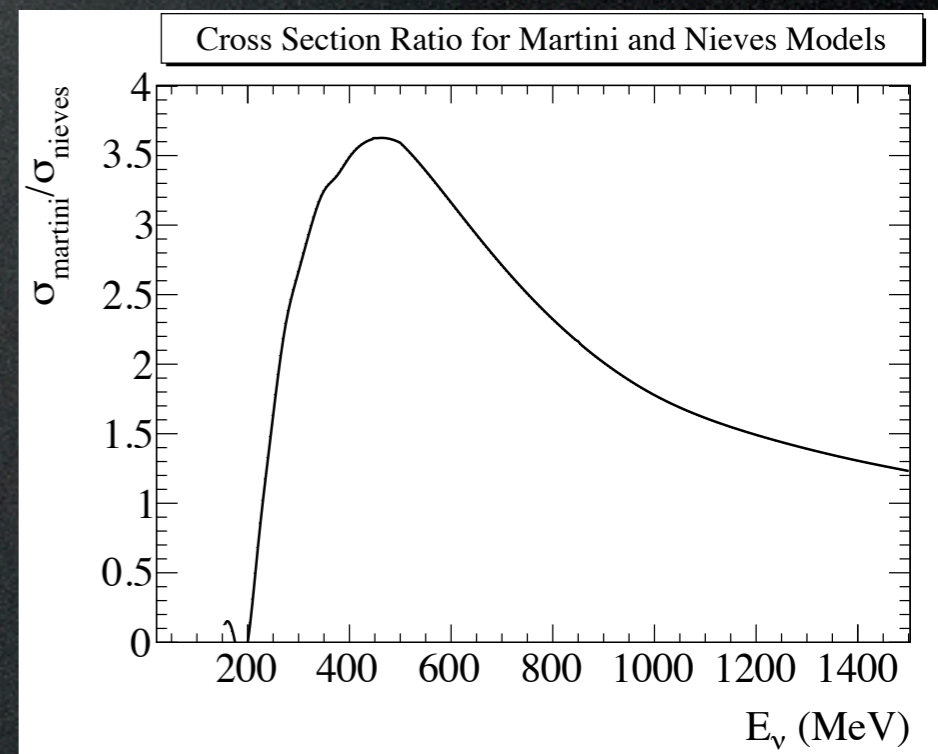
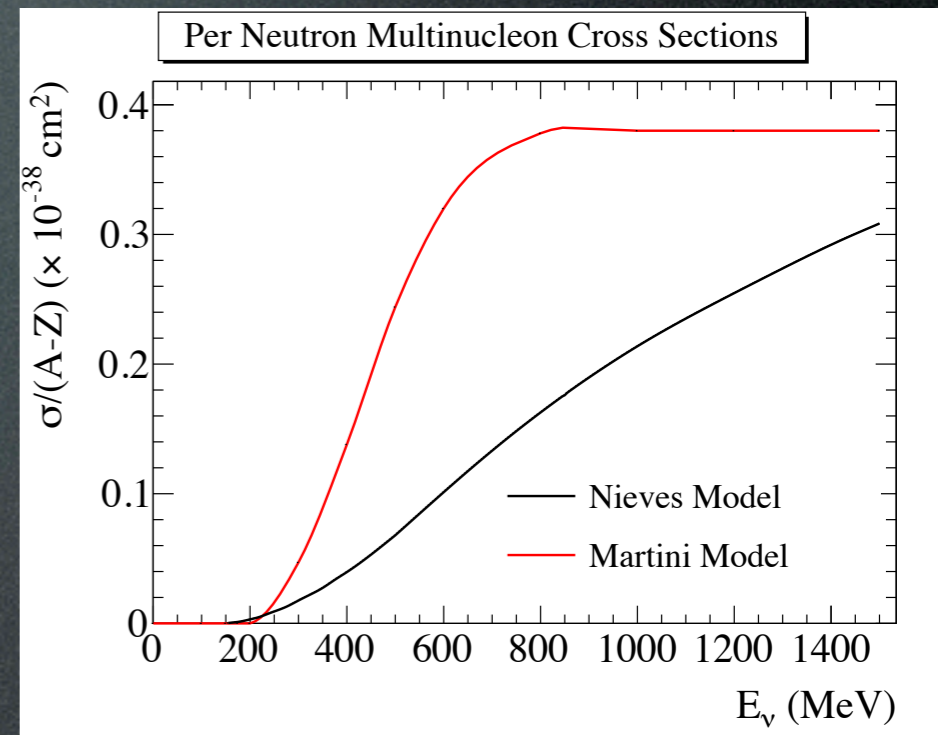

Isn't This is Why Oscillation Experiments Build Near Detectors?

- Shouldn't cross section systematics cancel in a near/far fit?
 - Some errors, like total normalization, will cancel
- However, multi-nucleon effect causes feed-down of events into oscillation dip
 - Cannot disentangle with near detectors
 - Energy spectrum is not oscillated
- More multi-nucleon = smaller dip
 - **Multi-nucleon effects are largely degenerate with mixing angle effect!**

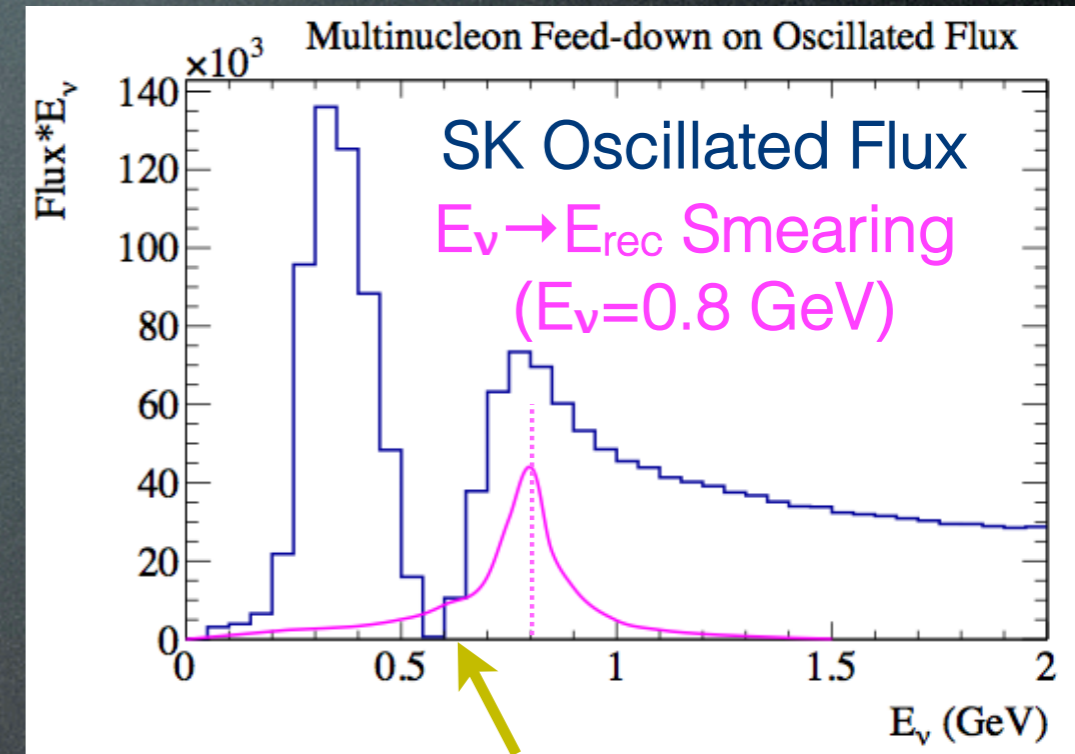

Mixing Angle Bias!

Near detectors lack sensitivity

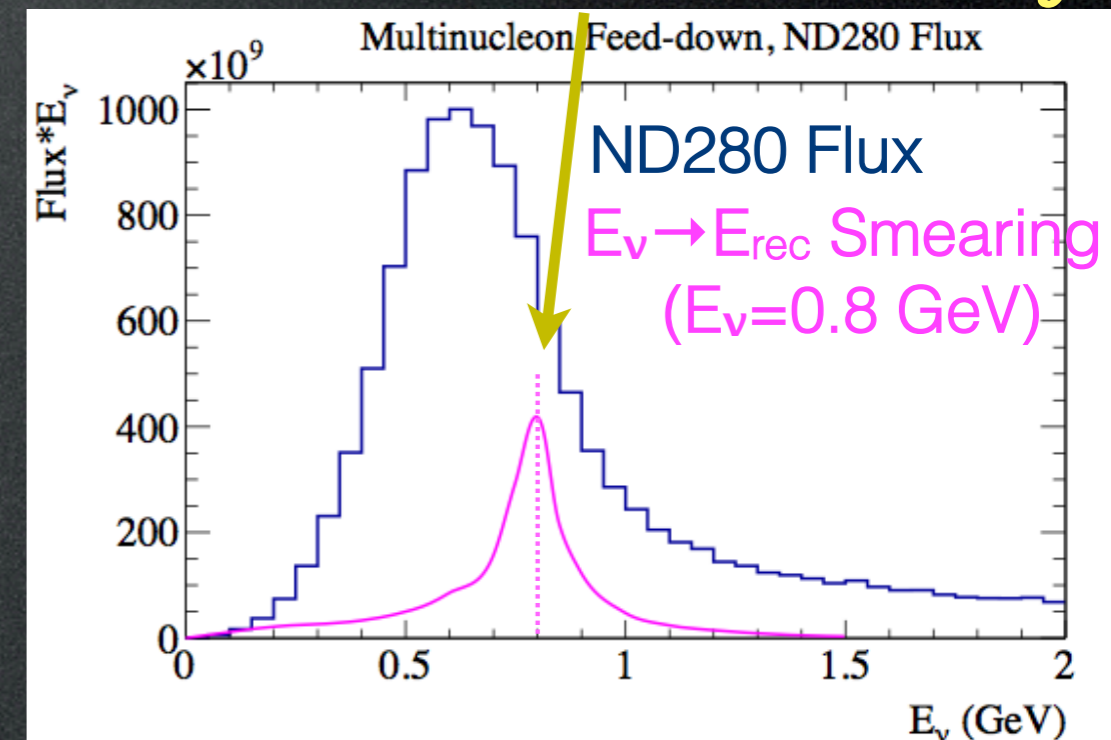

Effect on T2K ν_μ Disappearance

- Create “fake data” samples with flux and cross section variations
 - With and without multi-nucleon events
- For each fake data set, full T2K near/far oscillation fit is performed
 - For each variation, plot difference with and without multi-nucleon events
- For Nieves model, “average bias” (RMS) = **3.6%**
- For Martini model, mean bias = -2.9%, RMS = 3.2%
 - Full systematic = $\sqrt{(2.9\%^2 + 3.2\%^2)} = \mathbf{4.3\%}$
 - **This would be one of the largest systematic uncertainties**
- But this is just a comparison of 2 models
 - How much larger could the actual systematic uncertainty be?
- **We need a data-driven constraint!**

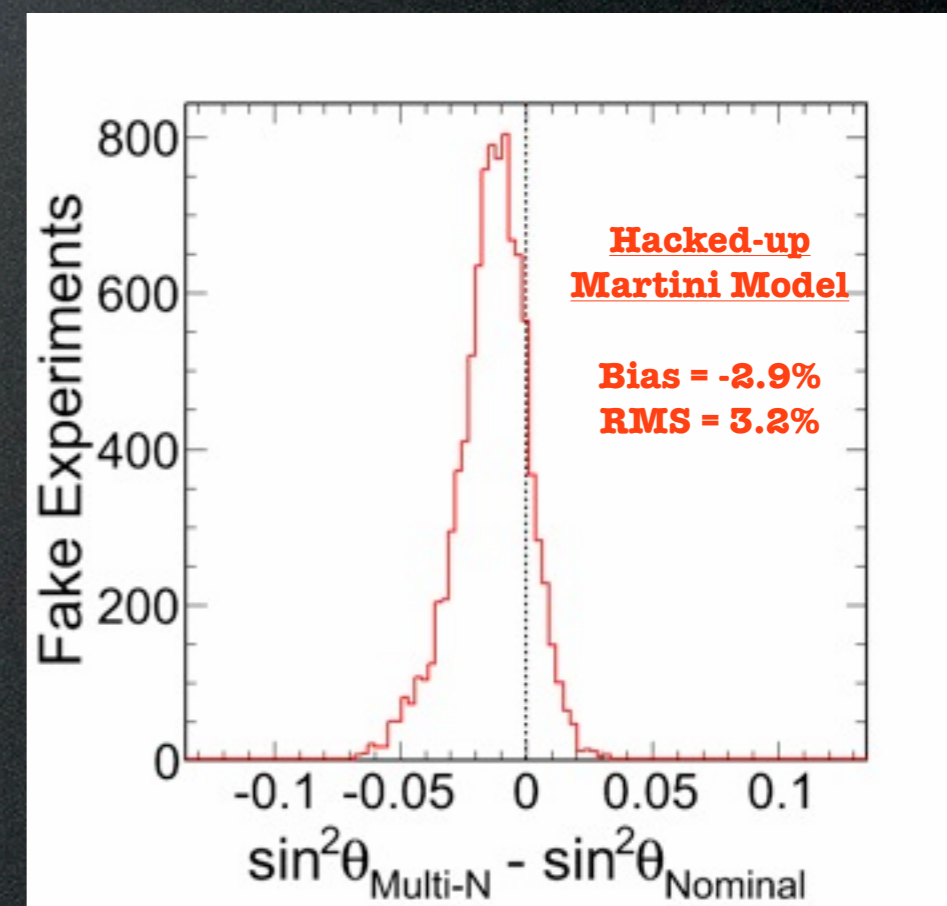
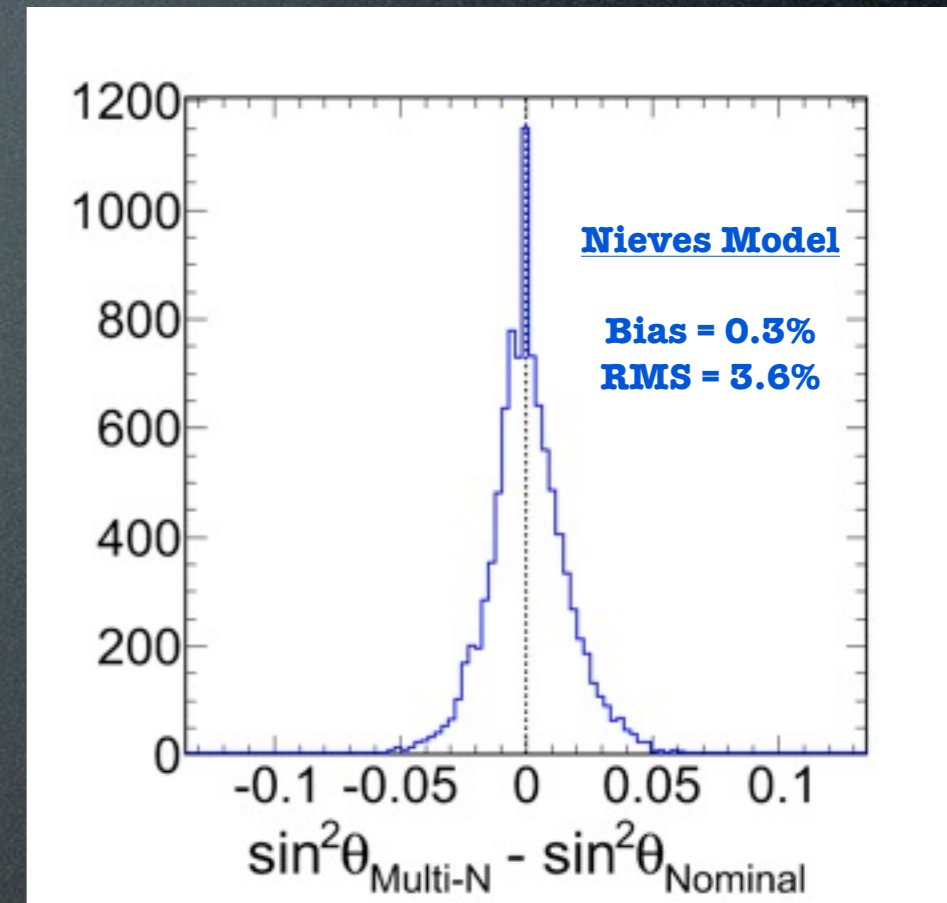

**Can the E_ν problem be
solved experimentally?**

nuPRISM Detector Concept



nuPRISM Detector Concept

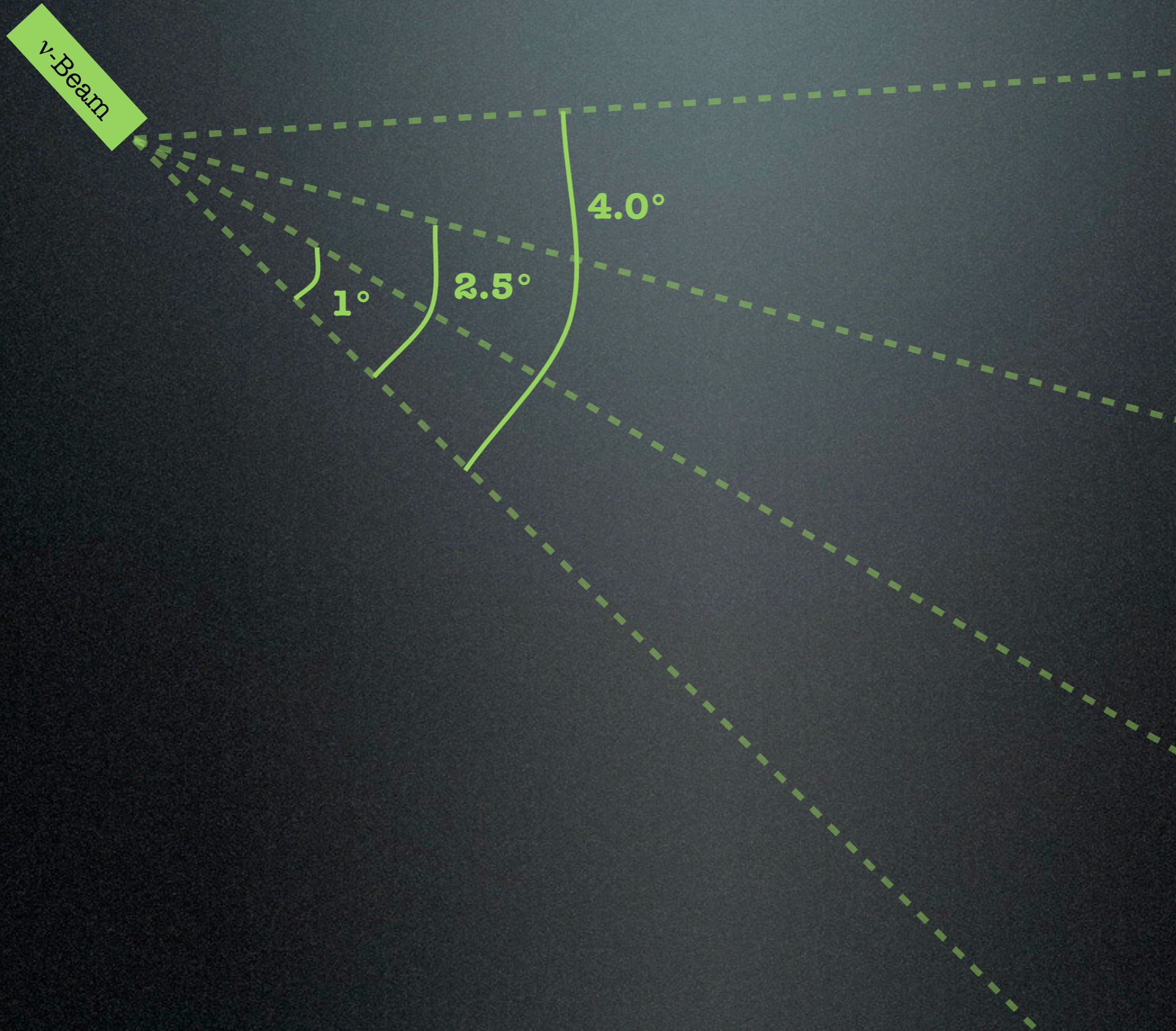

nuPRISM Detector Concept

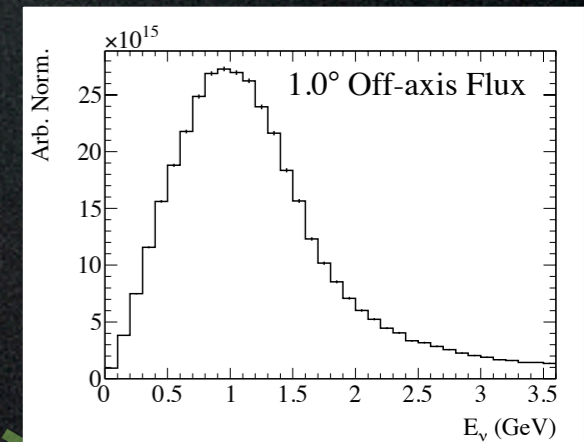
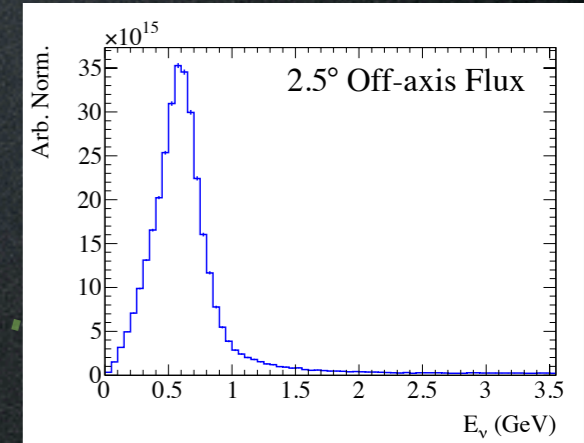
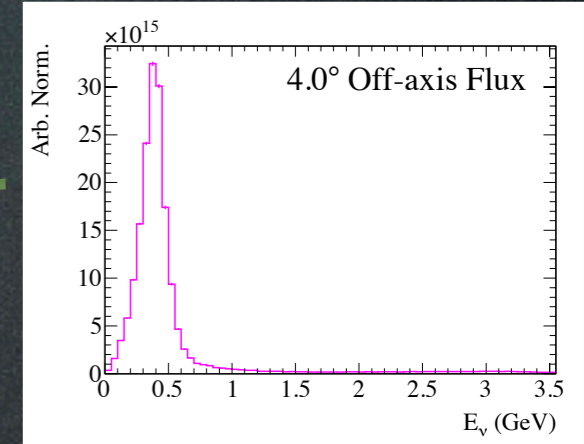
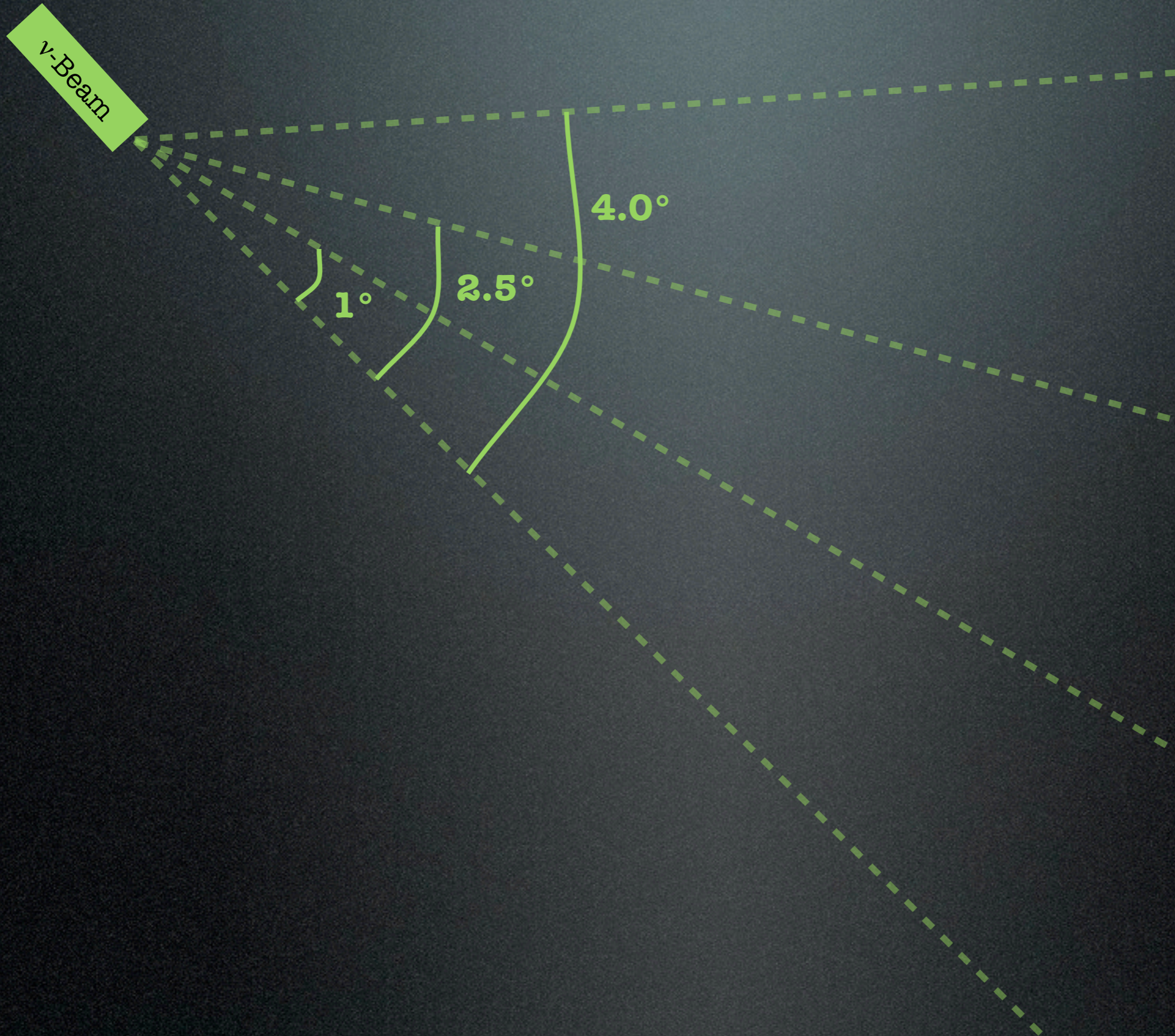

nuPRISM Detector Concept

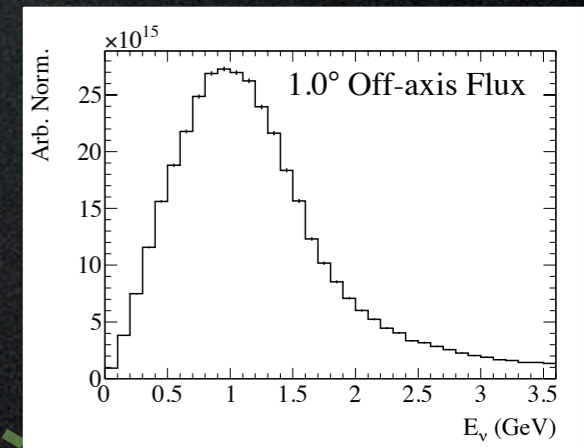
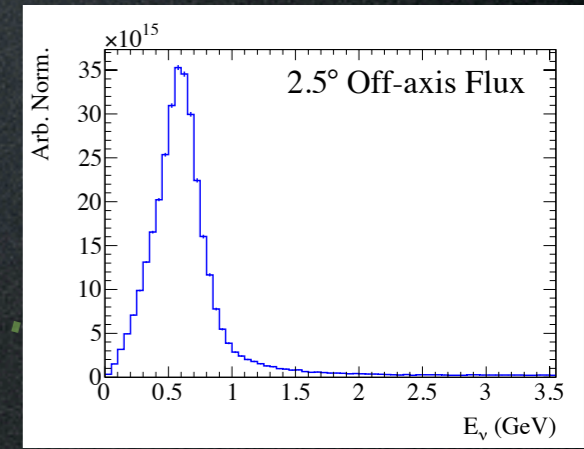
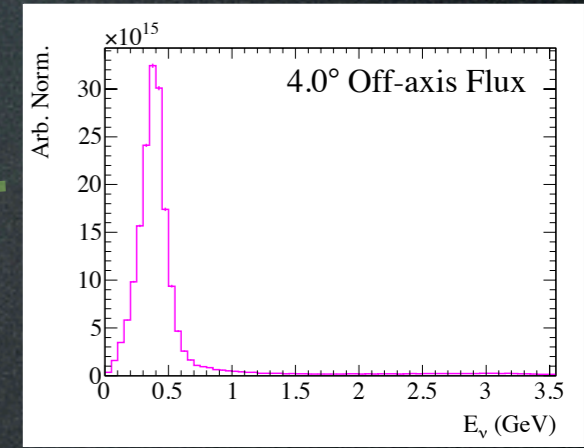
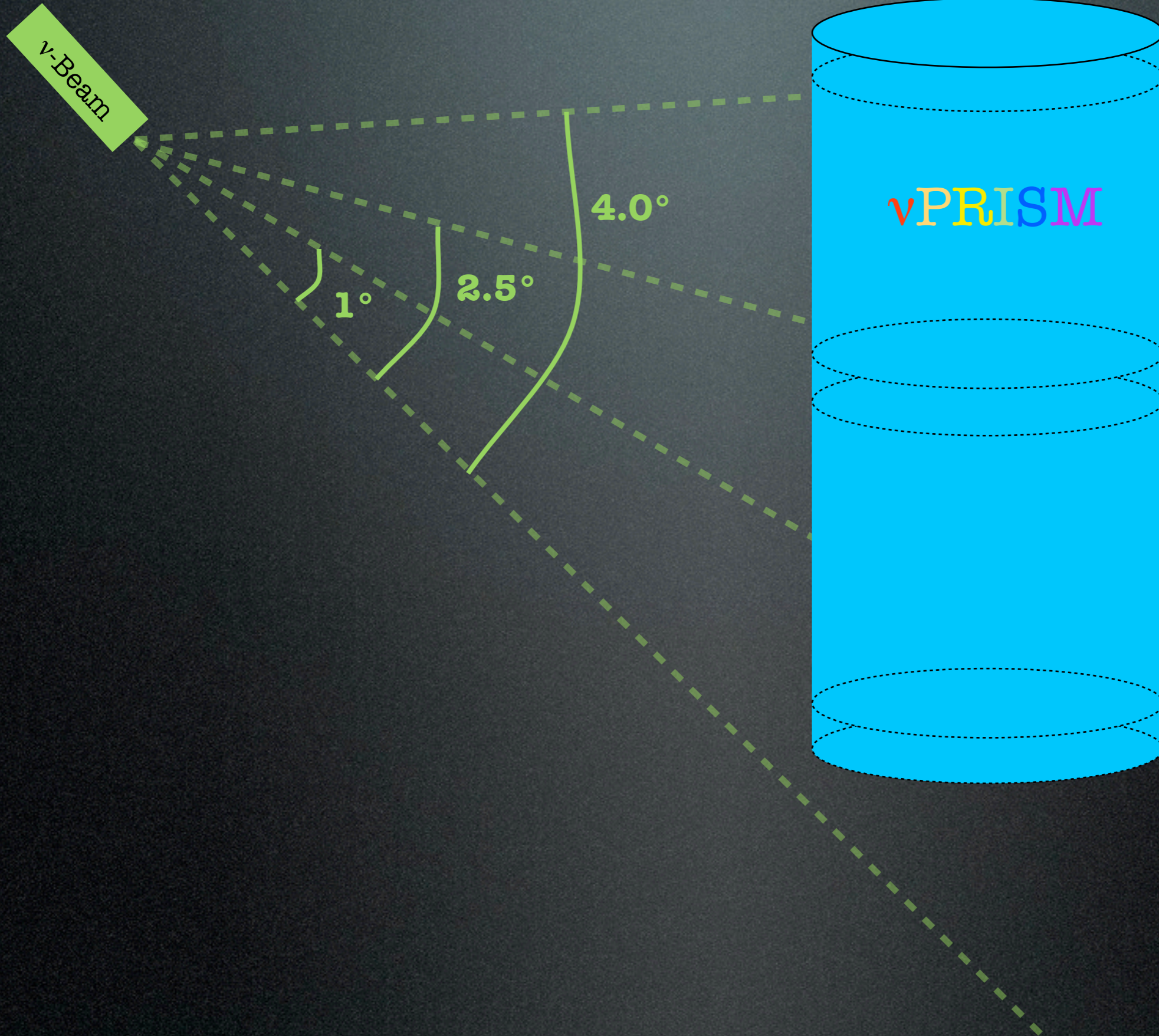

nuPRISM Detector Concept

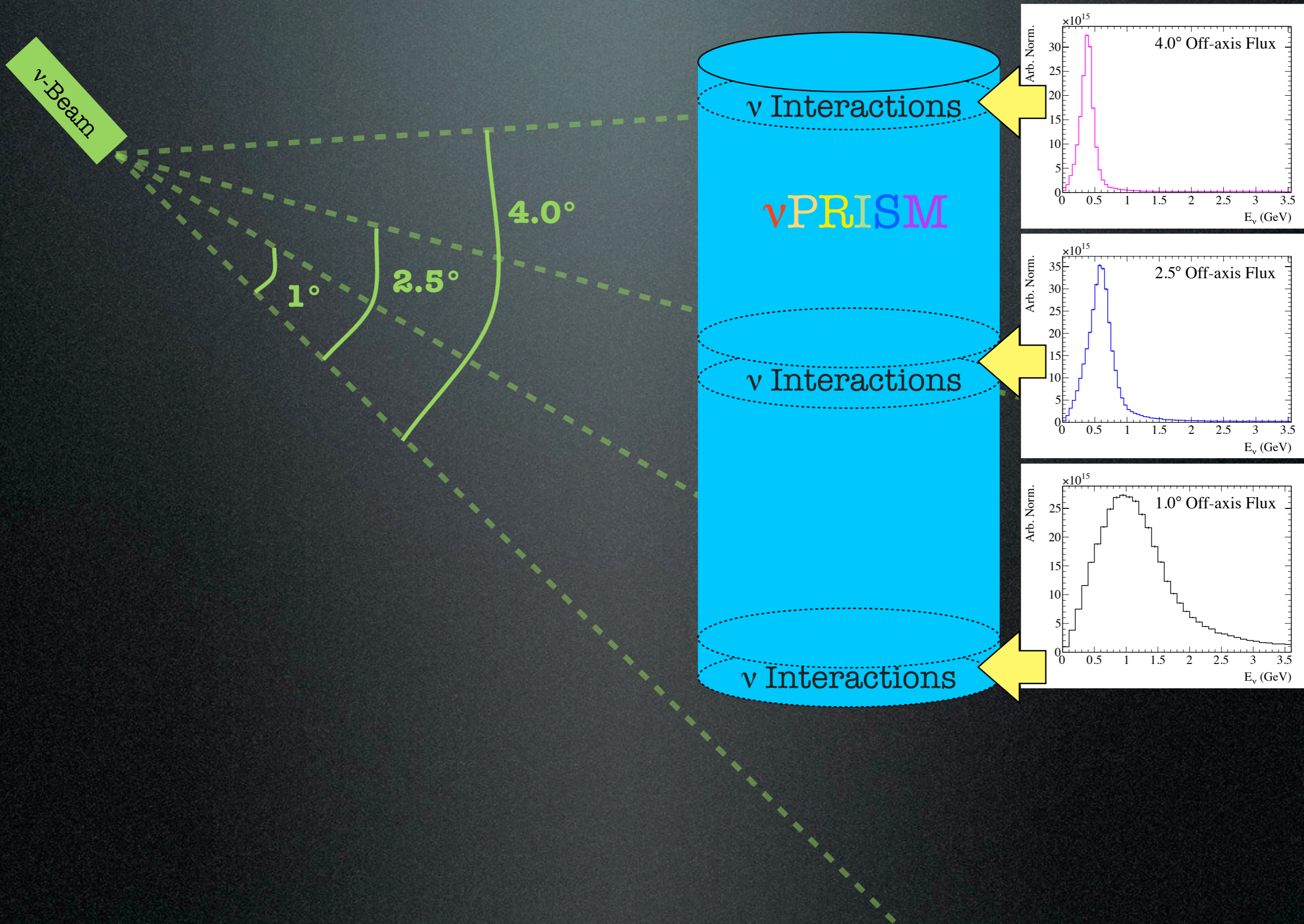

nuPRISM Detector Concept

ν -Beam

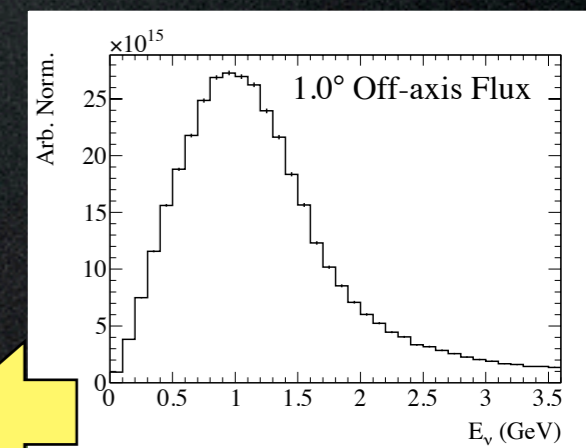
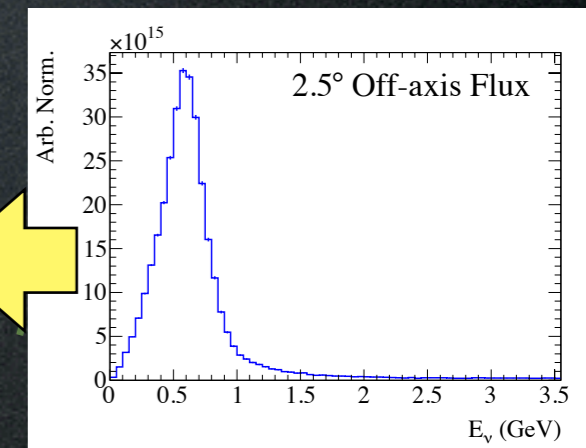
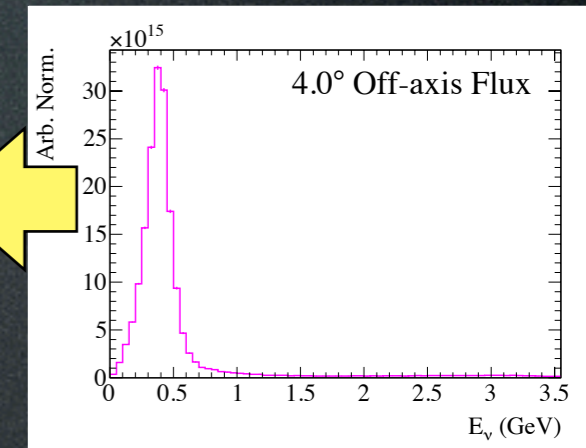
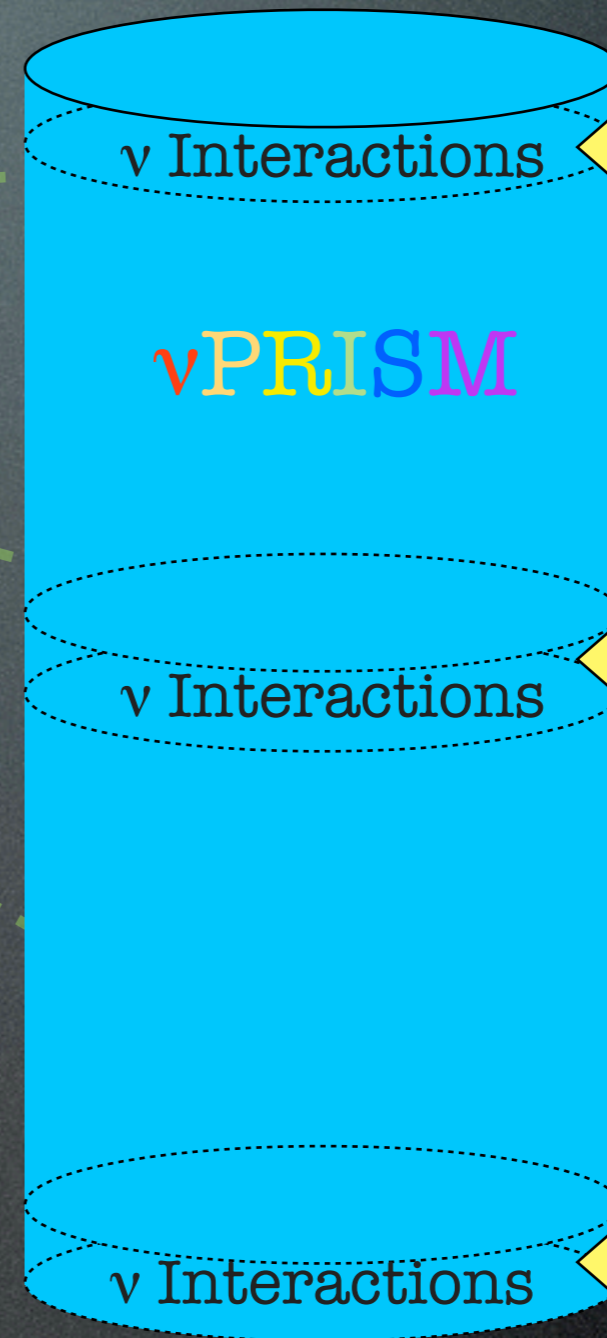
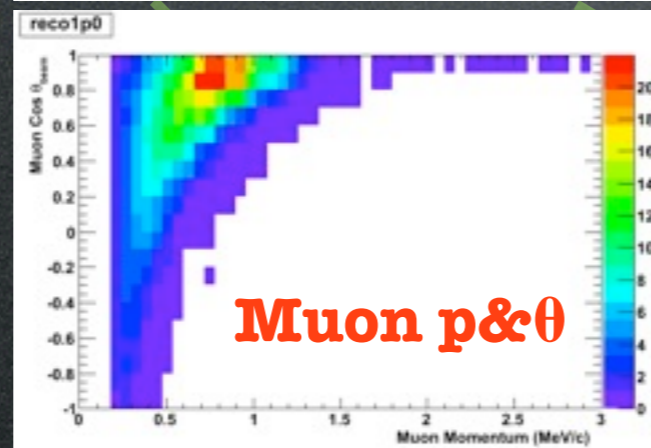
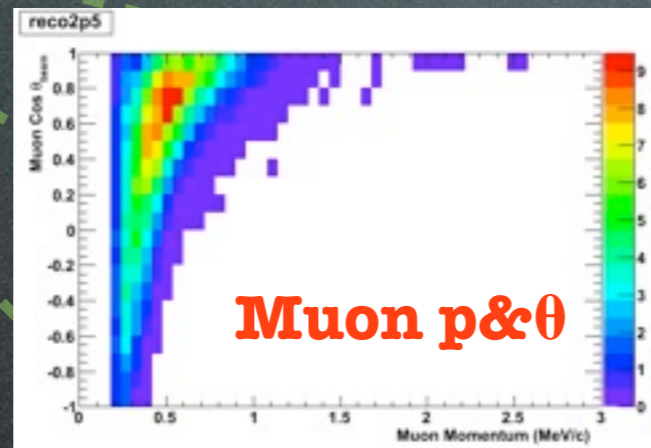
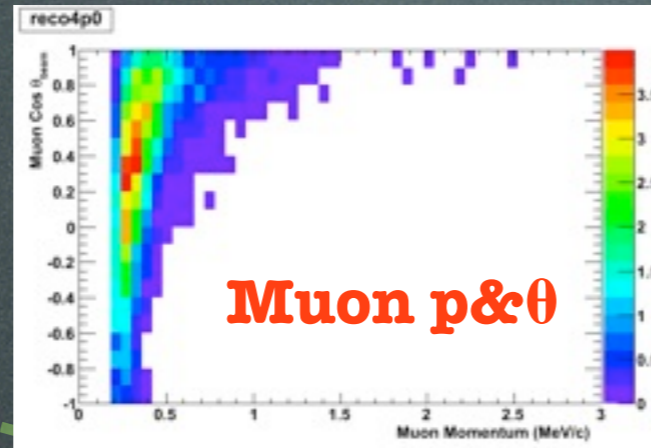

nuPRISM Detector Concept

ν -Beam

Take linear combinations!

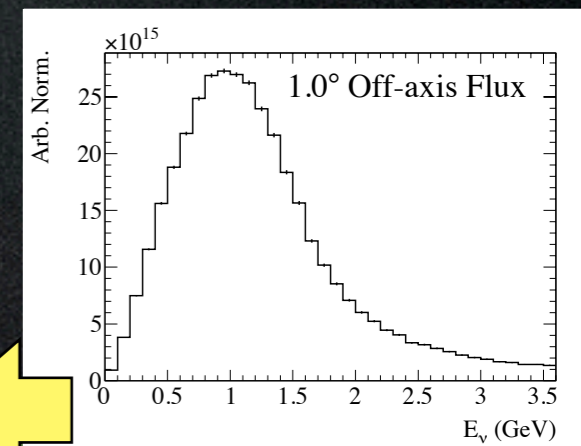
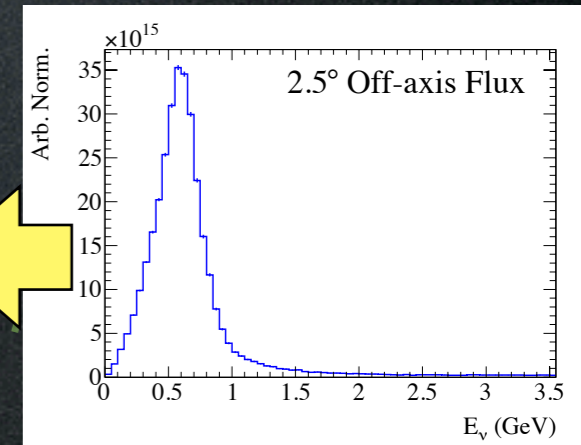
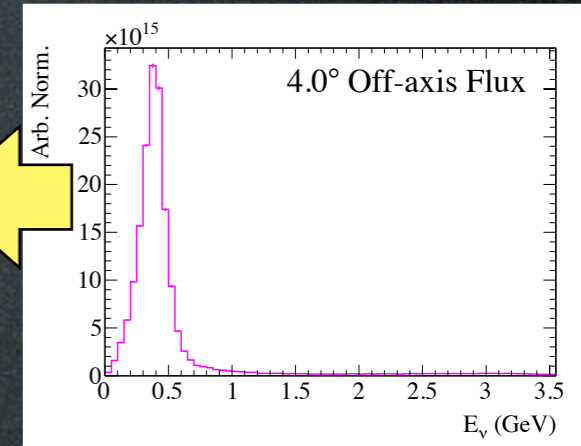
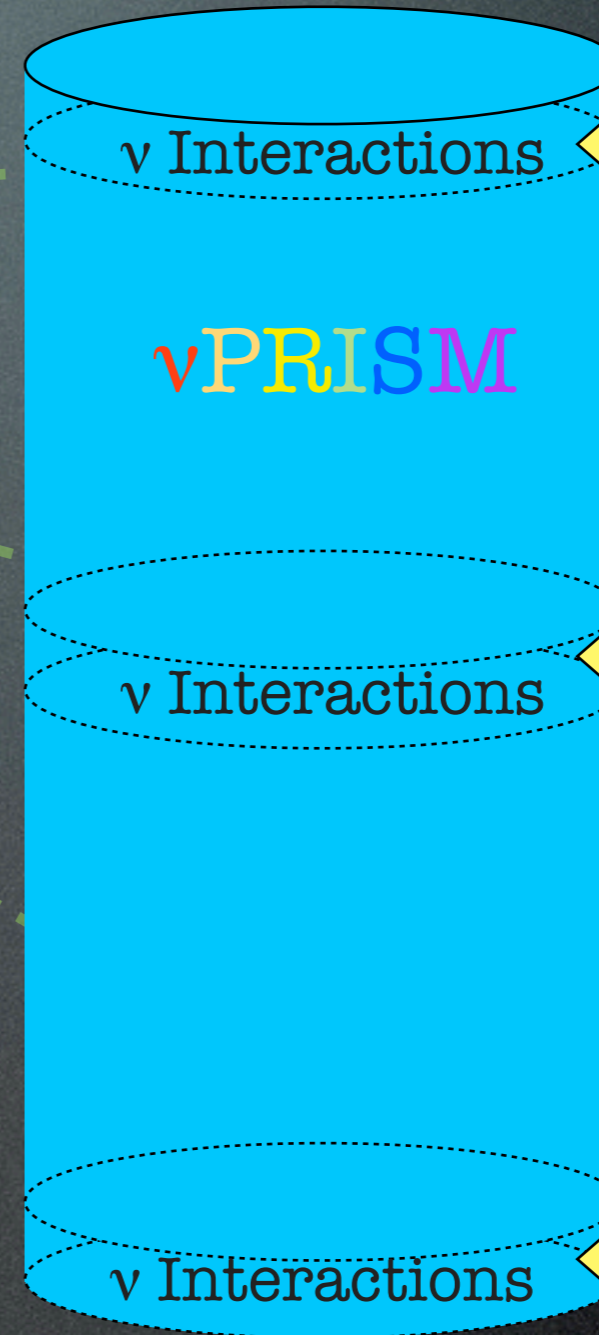
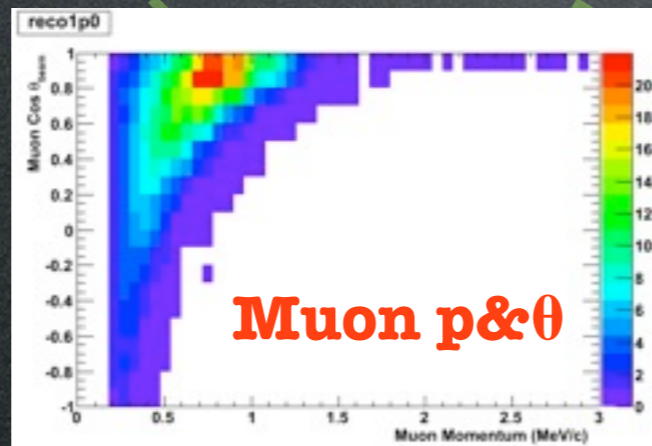
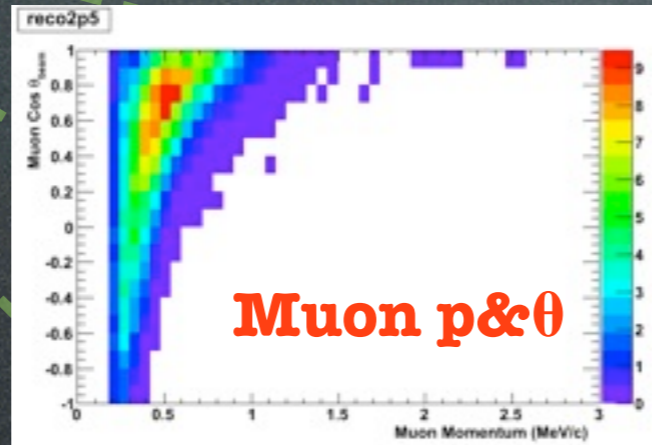
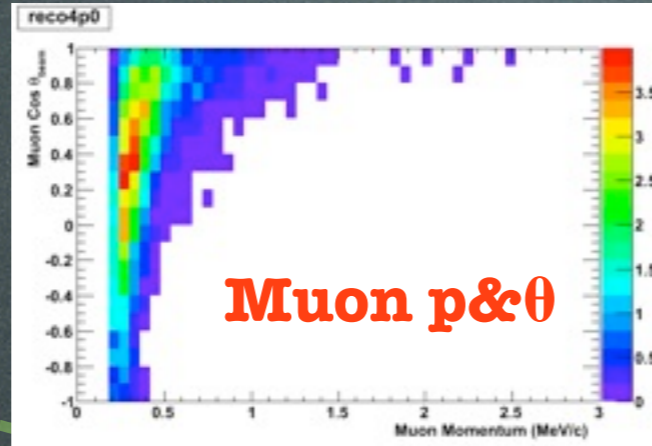

nuPRISM Detector Concept

ν -Beam

-0.5 *

Take linear combinations!

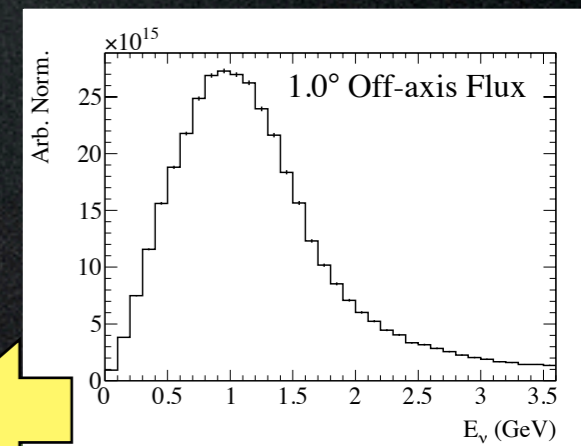
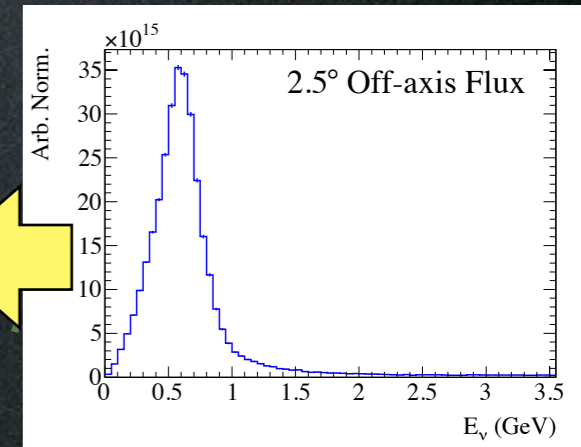
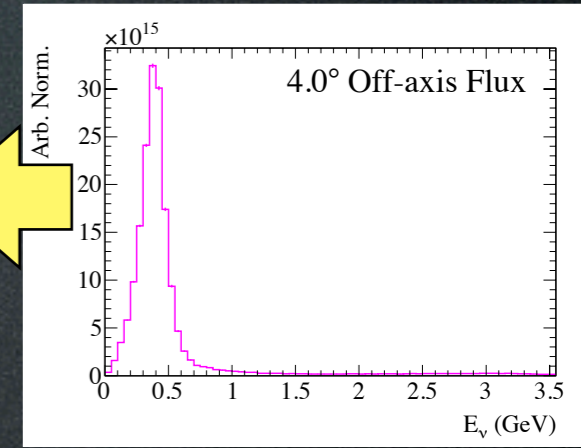
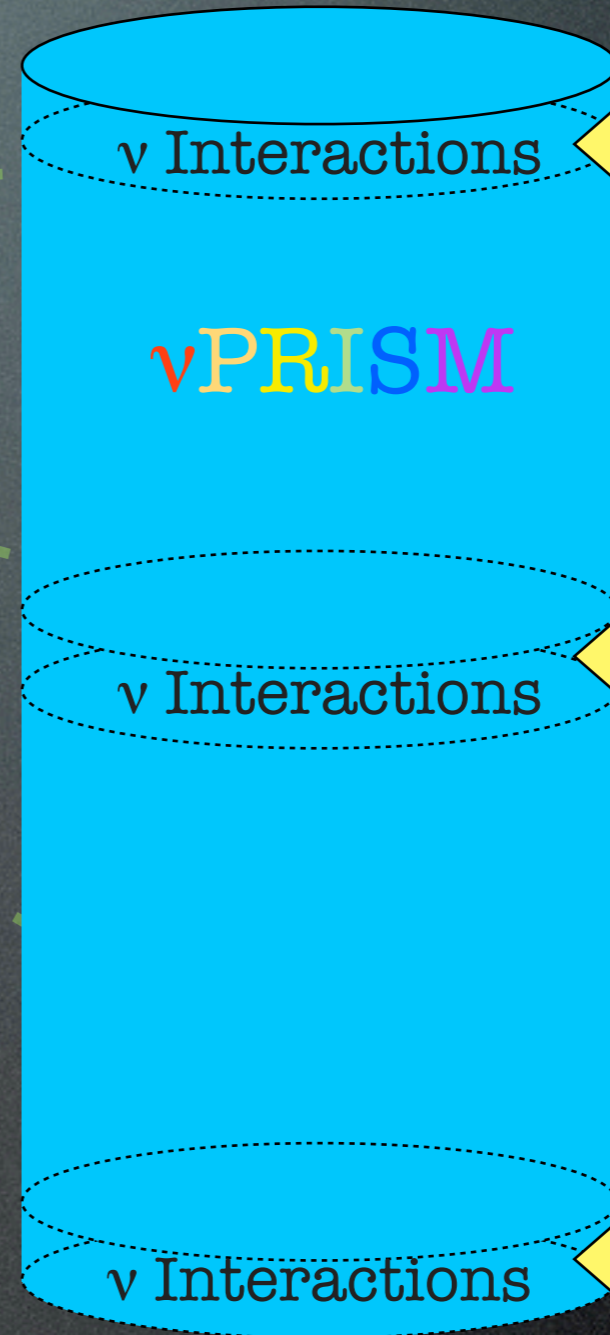
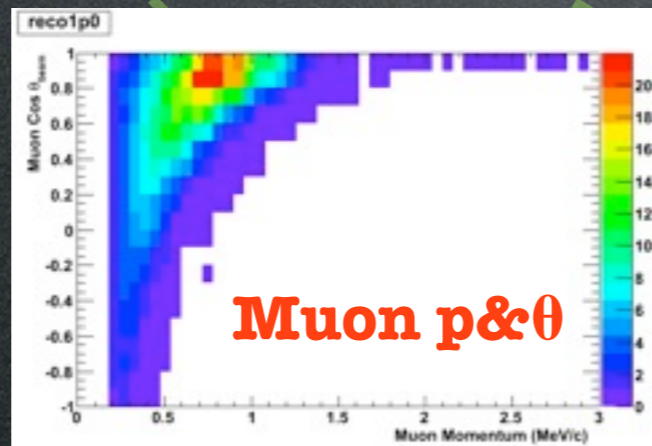
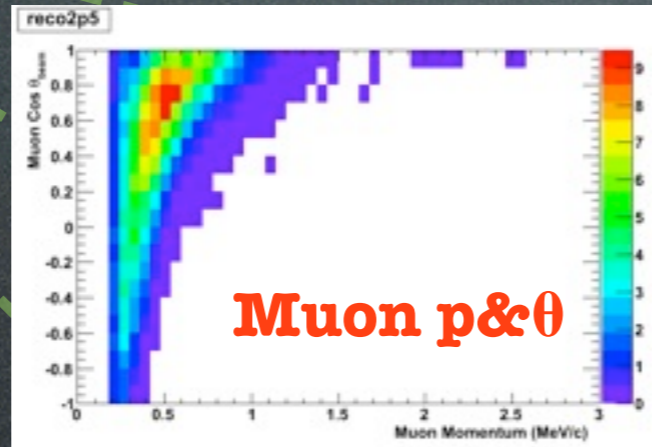
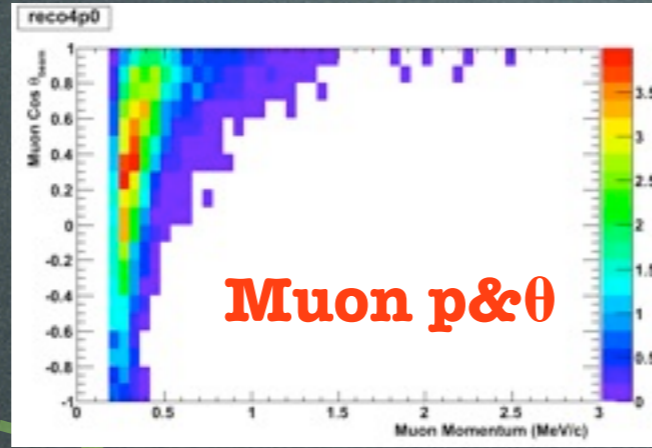

nuPRISM Detector Concept

ν -Beam

-0.5 *

+1.0 *

Take linear combinations!

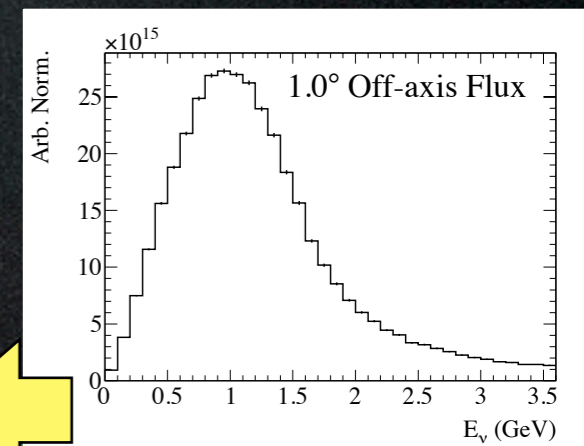
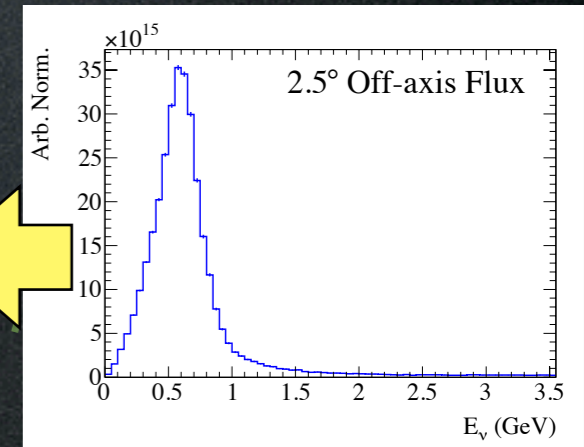
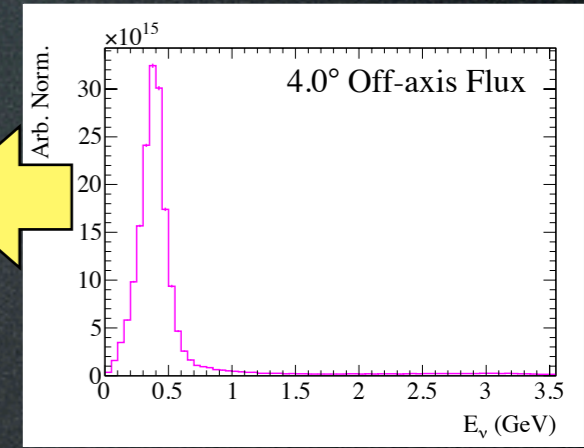
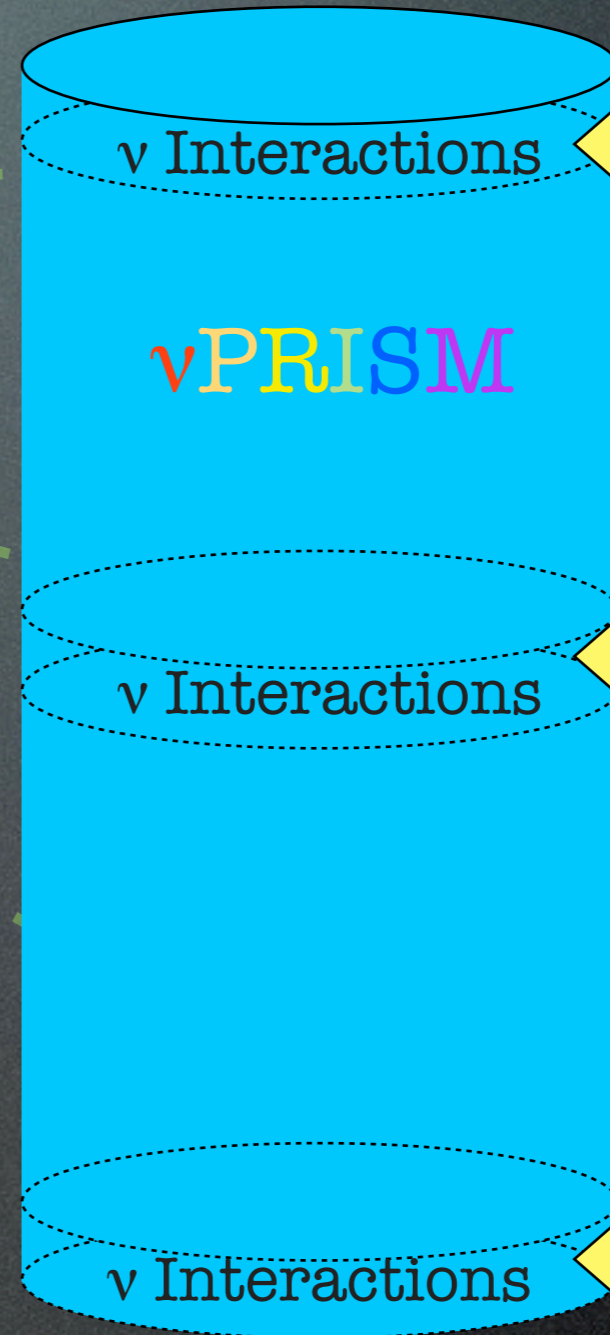
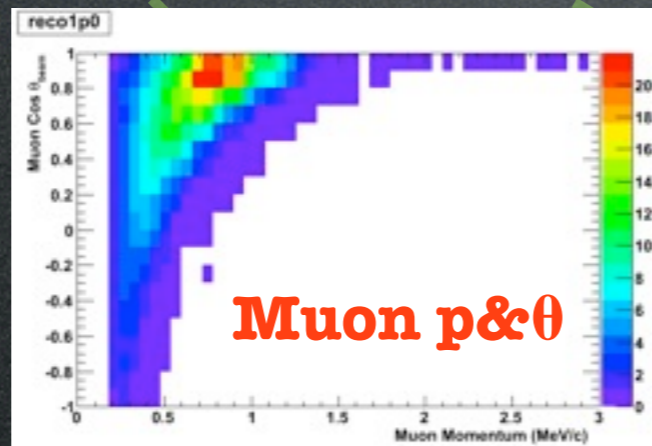
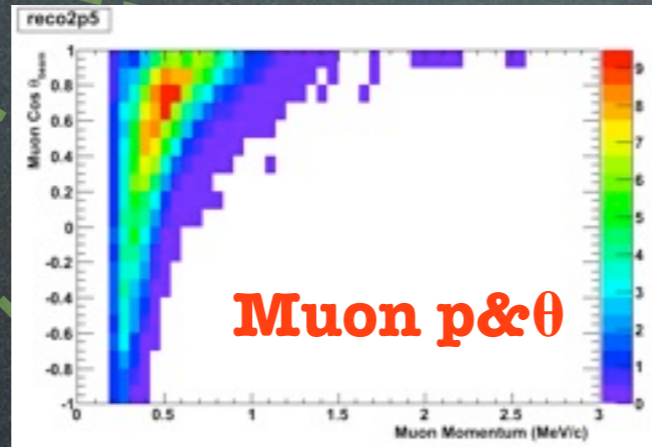
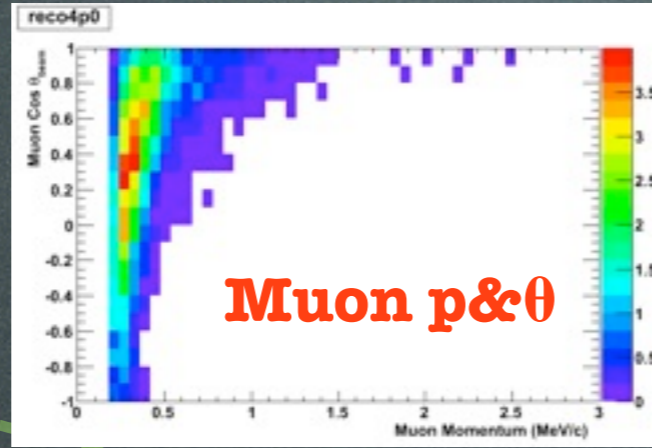

nuPRISM Detector Concept

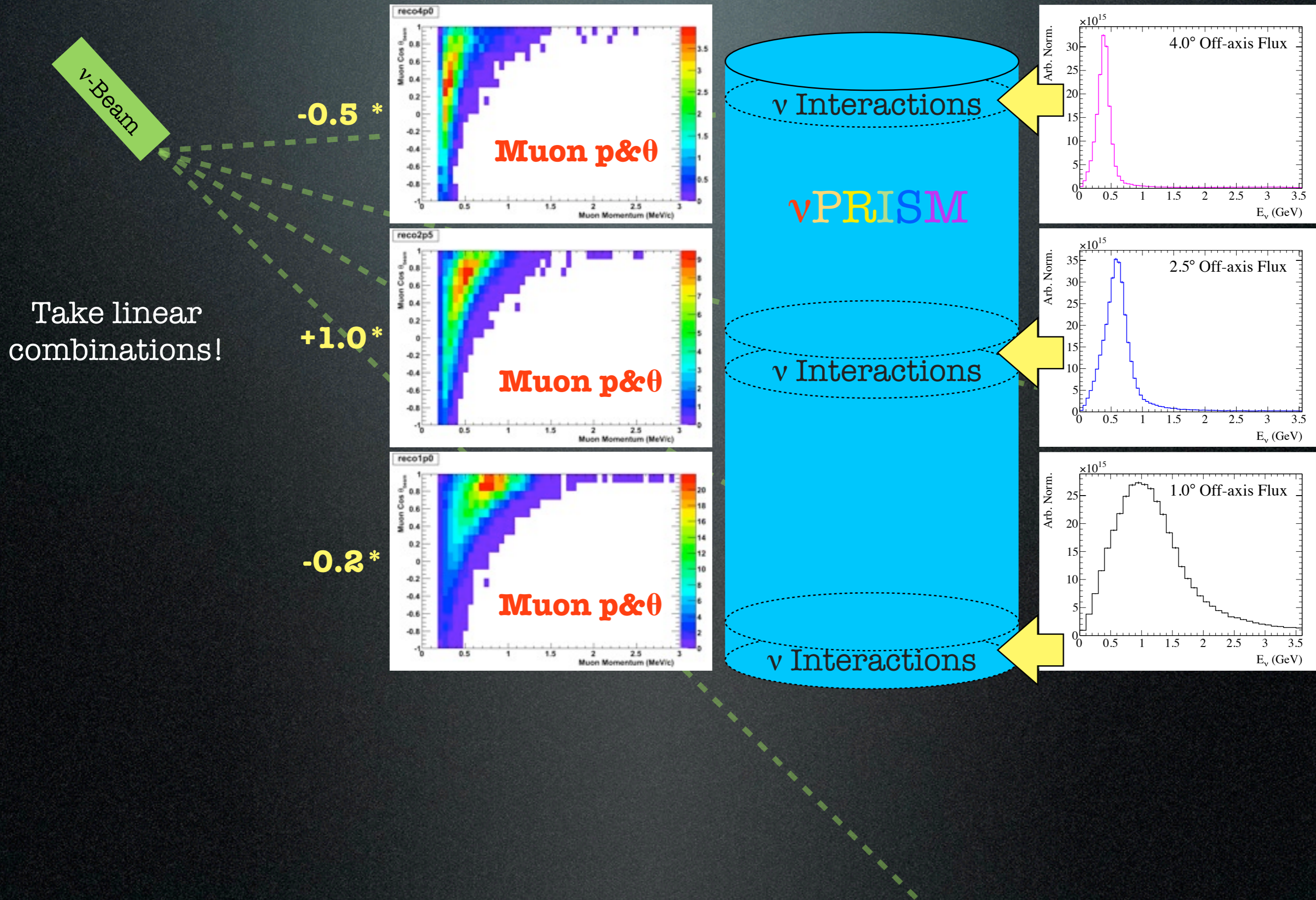

nuPRISM Detector Concept

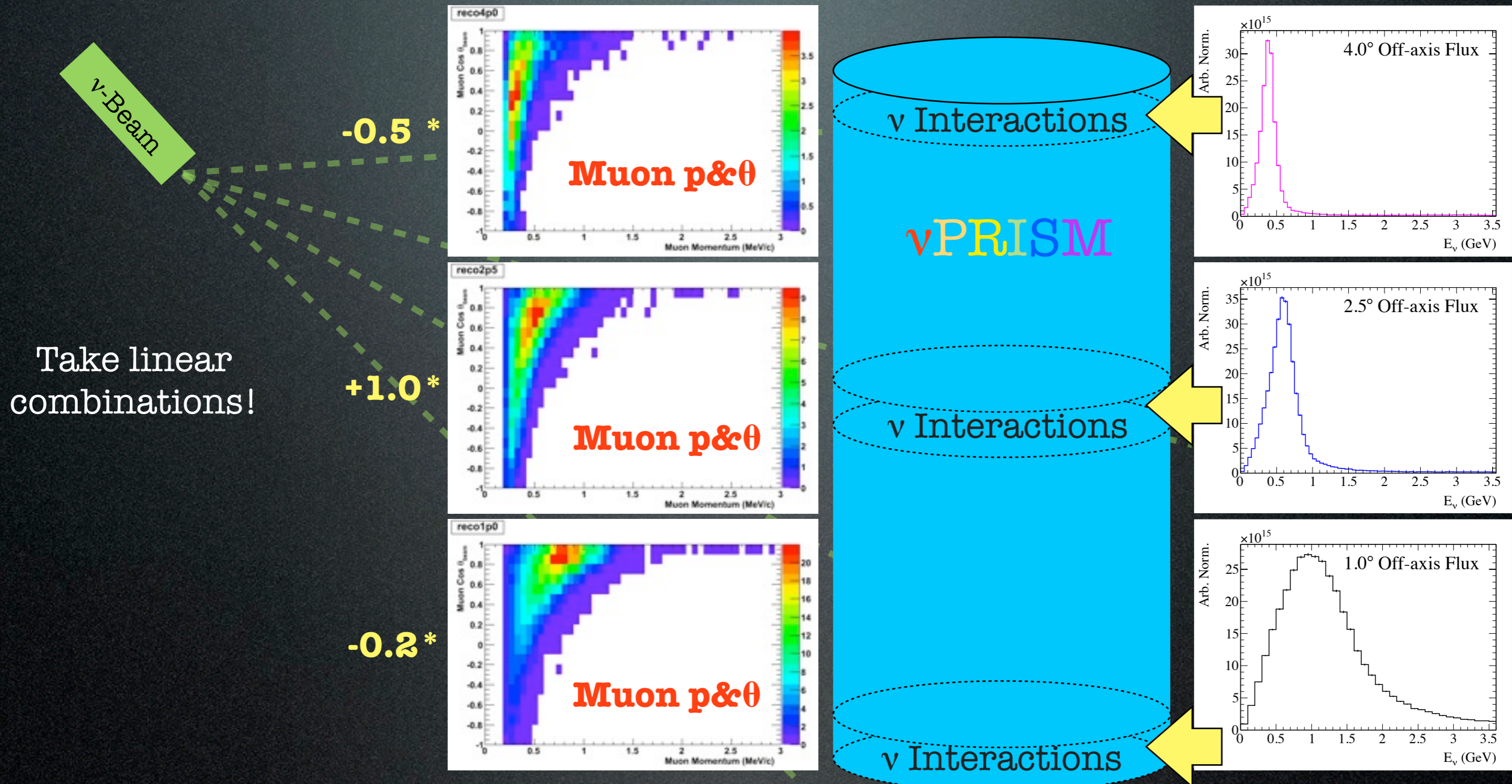

nuPRISM Detector Concept

ν -Beam

-0.5^*

$+1.0^*$

-0.2^*

Take linear combinations!

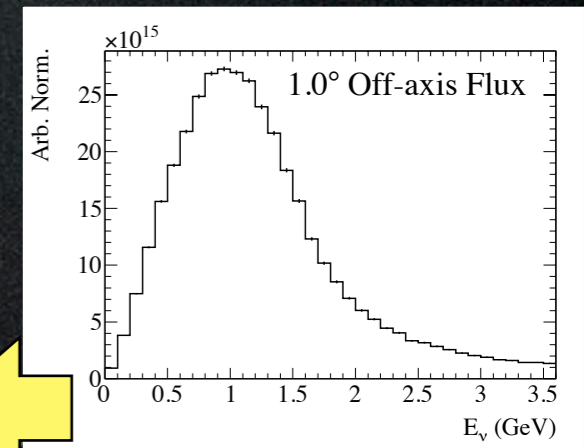
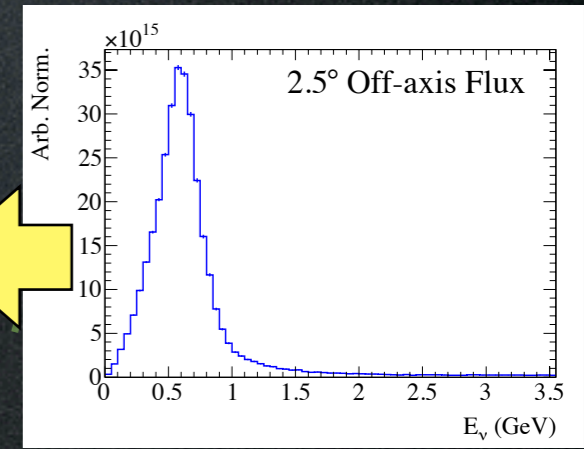
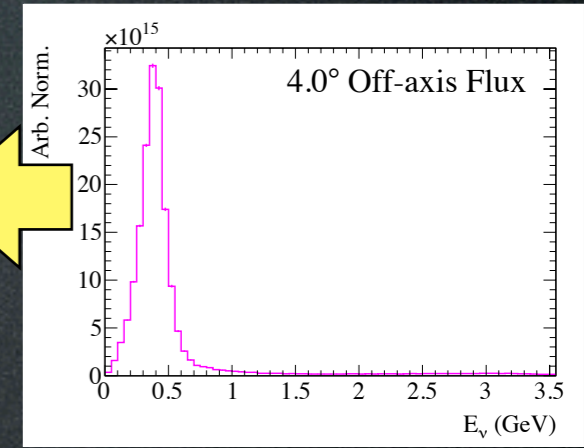
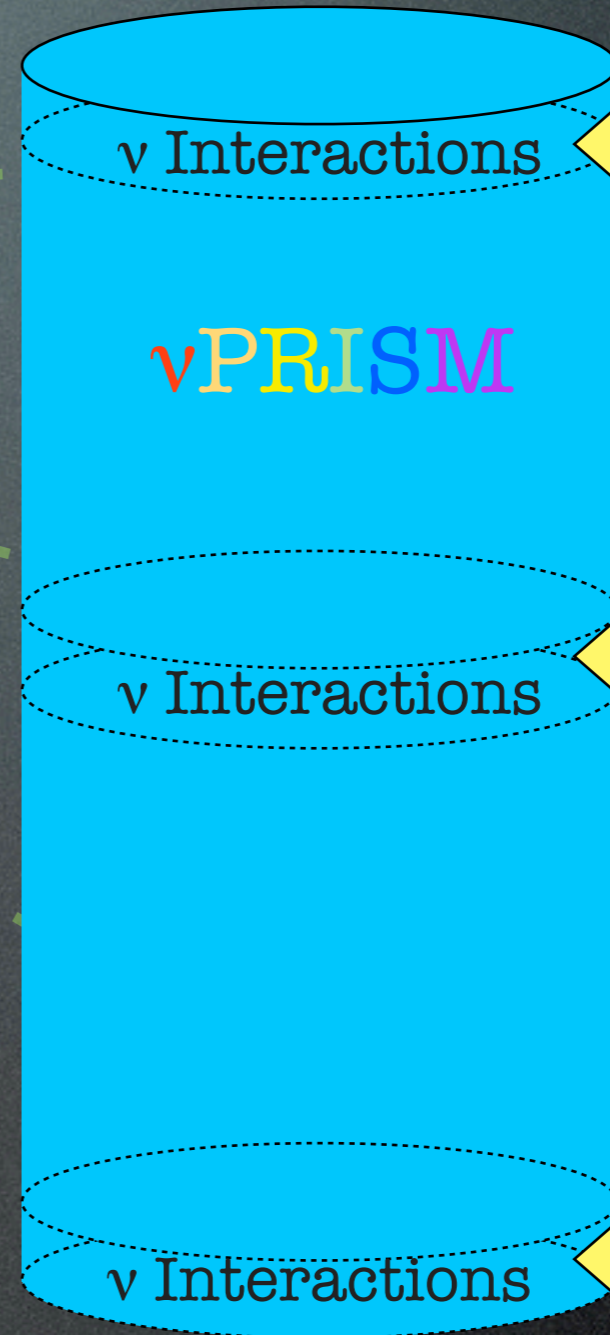
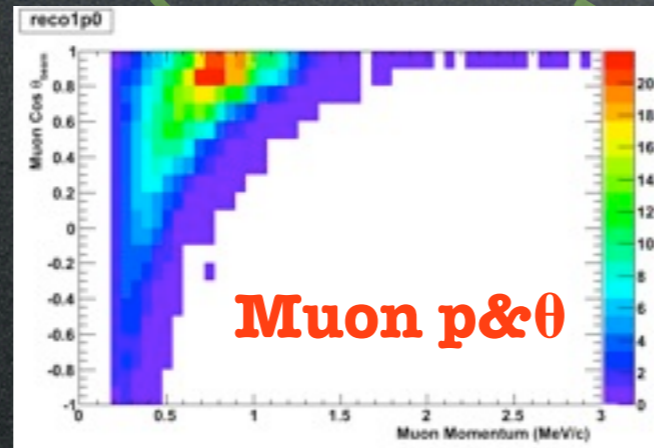
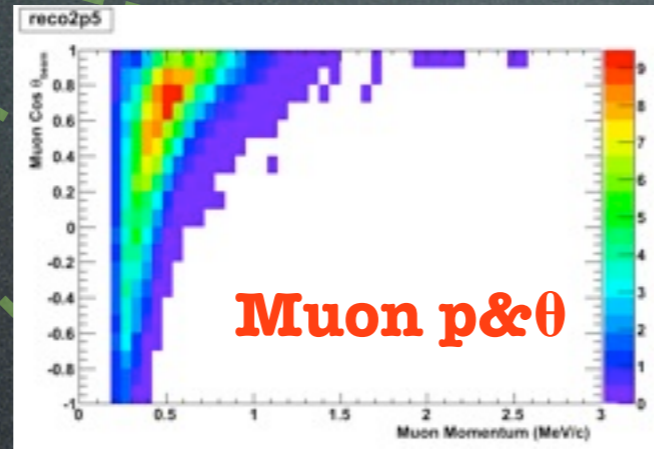
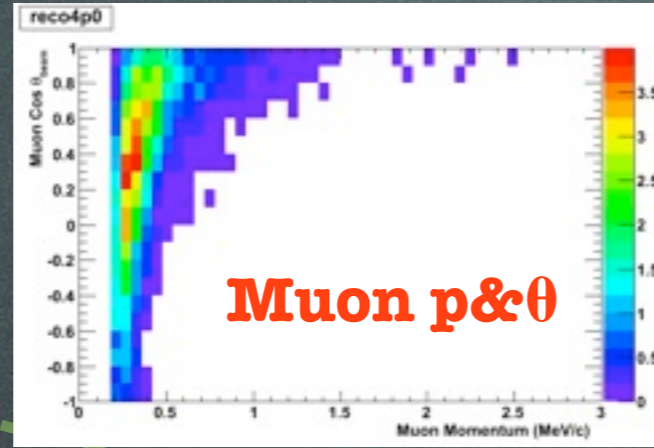

**Muon p& θ
for 700 MeV
Monoenergetic
 ν -Beam!**

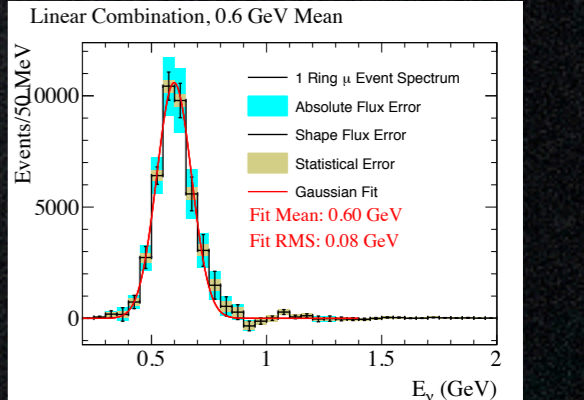

nuPRISM Detector Concept

ν -Beam

-0.5 *

+1.0 *

Take linear combinations!

600 MeV Monoenergetic Beam
using 60 slices
in off-axis angle

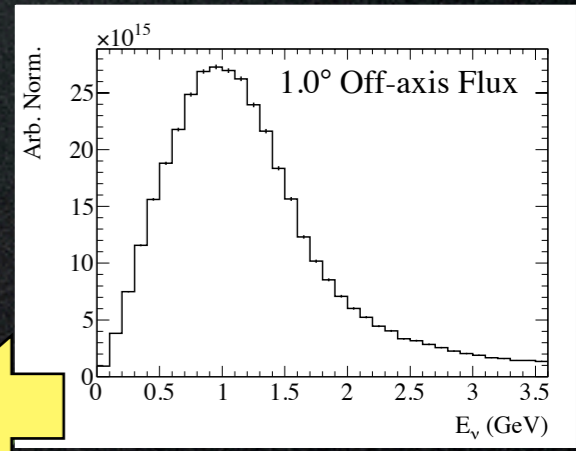
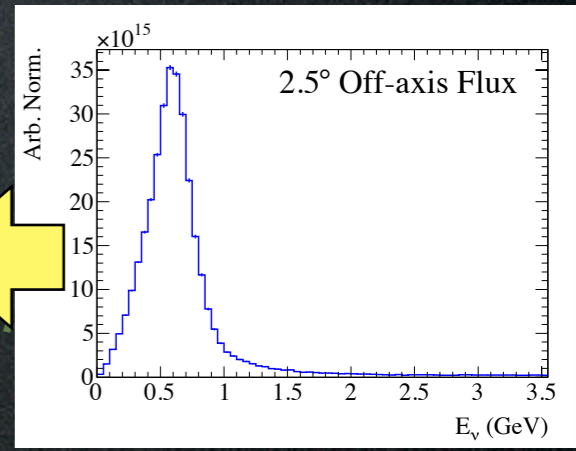
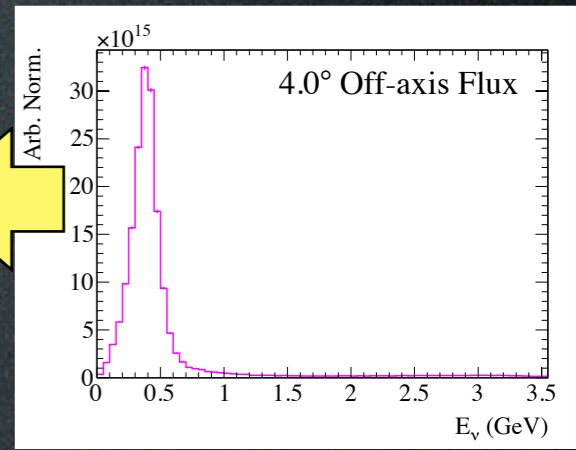
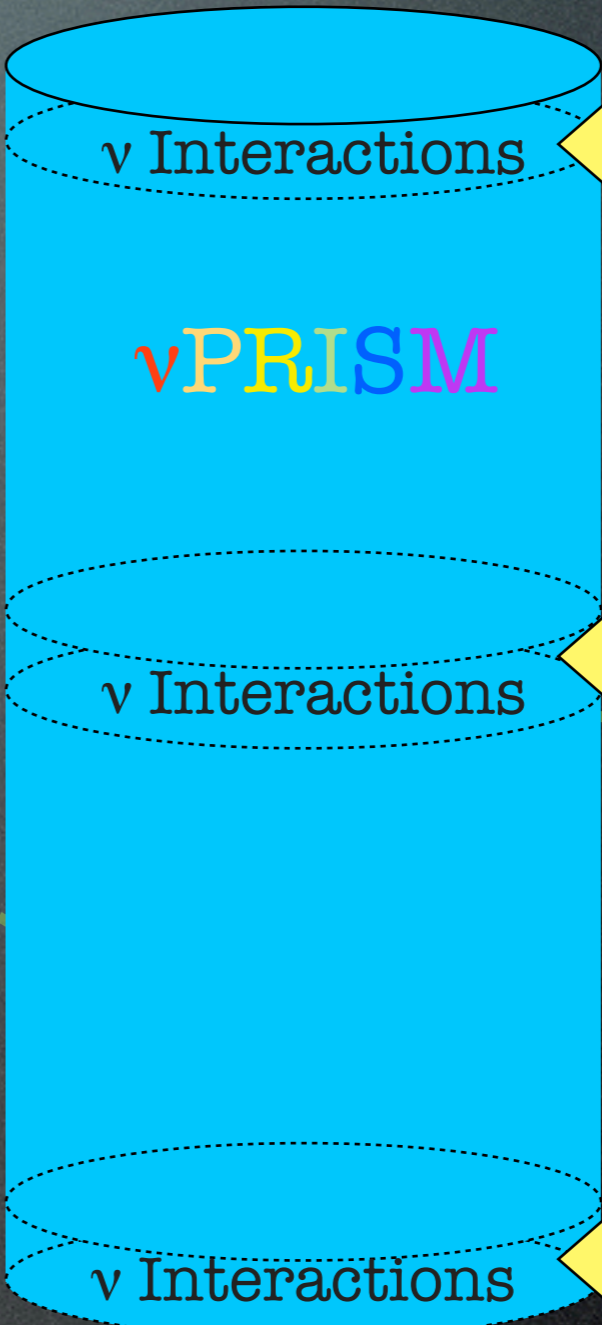
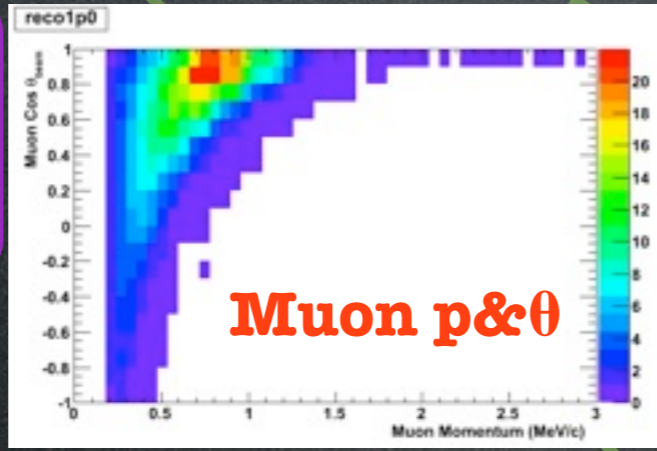
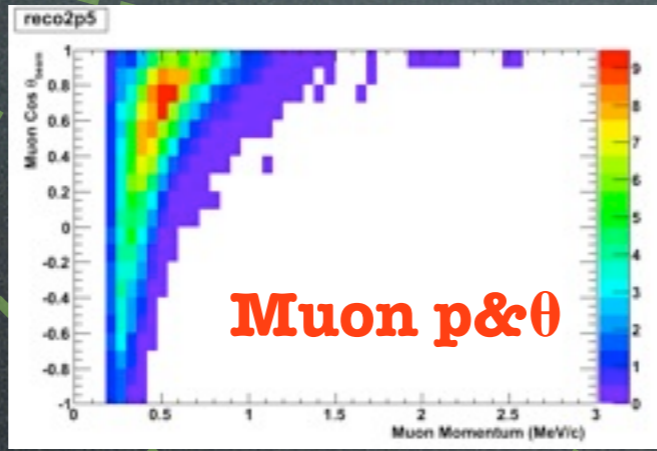
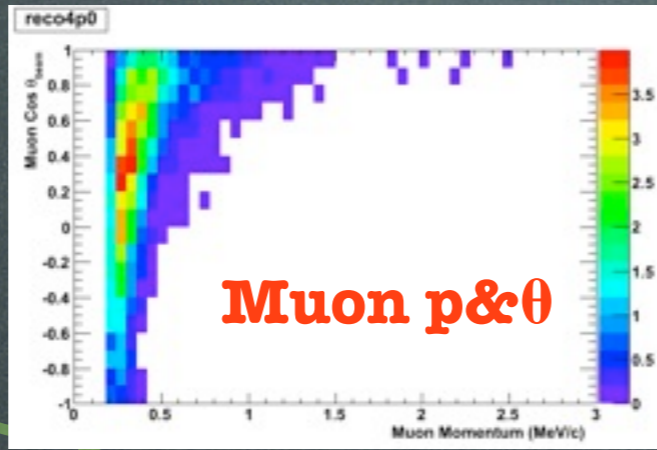
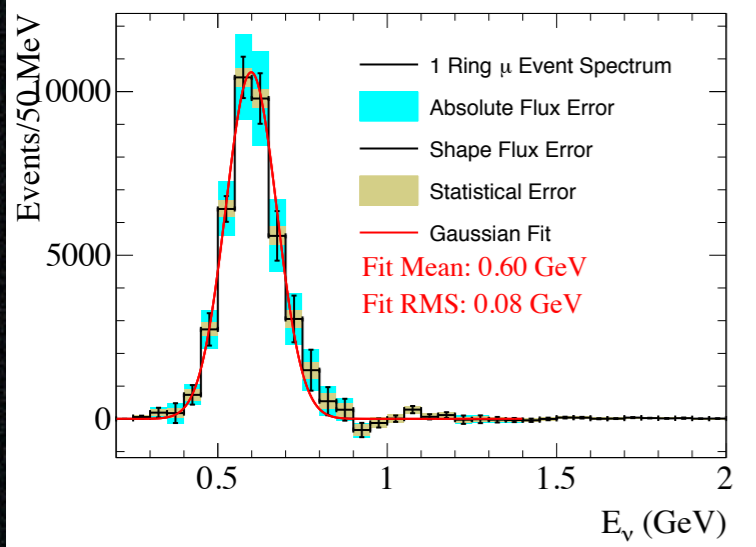

Muon $p \& \theta$
for 700 MeV
Monoenergetic
 ν -Beam!

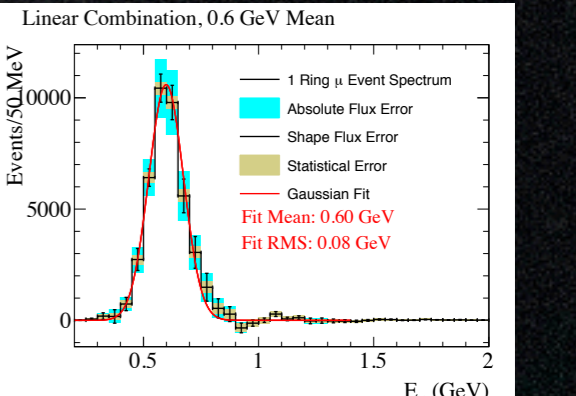

Benefits of a Monoenergetic Beam

- First ever measurements of NC events with E_ν
 - Much better constraints on NC oscillation backgrounds
- First ever “correct” measurements of CC events with E_ν
 - No longer rely on final state particles to determine E_ν
- It is now possible to separate the various components of single- μ events!

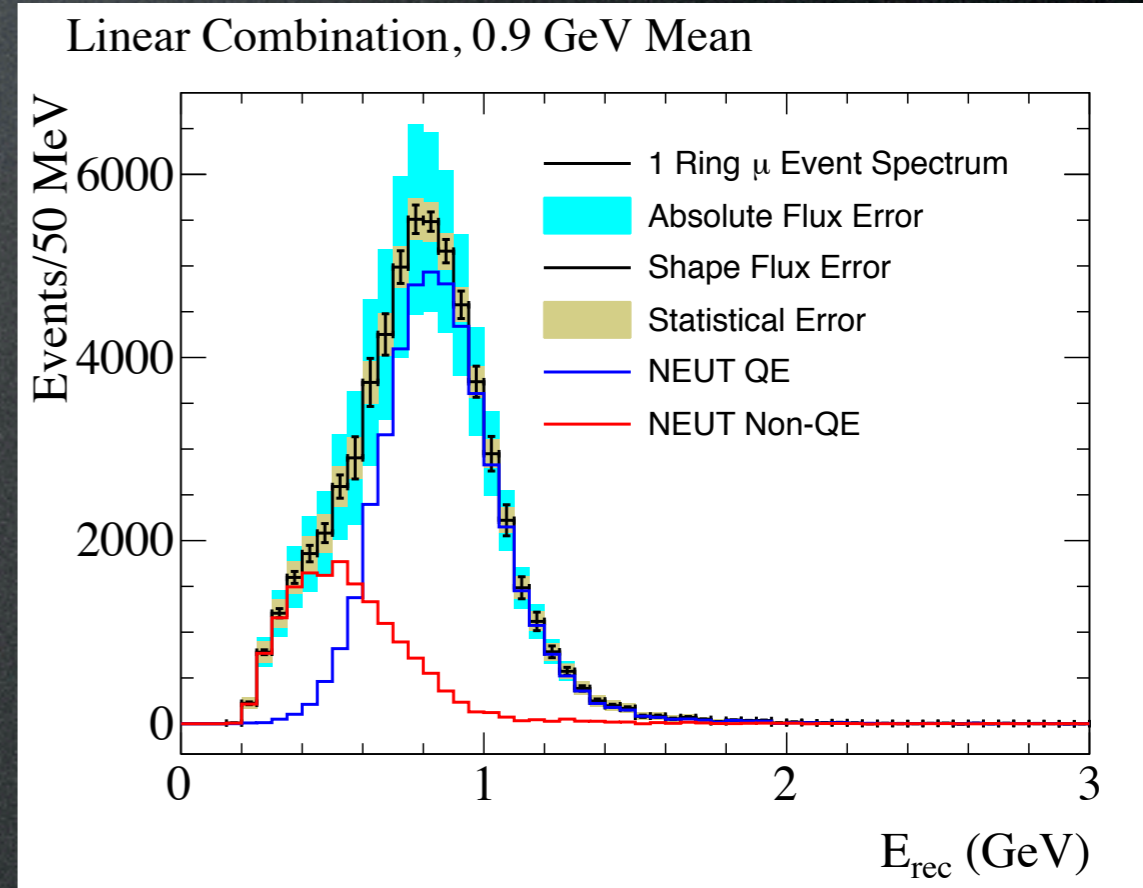
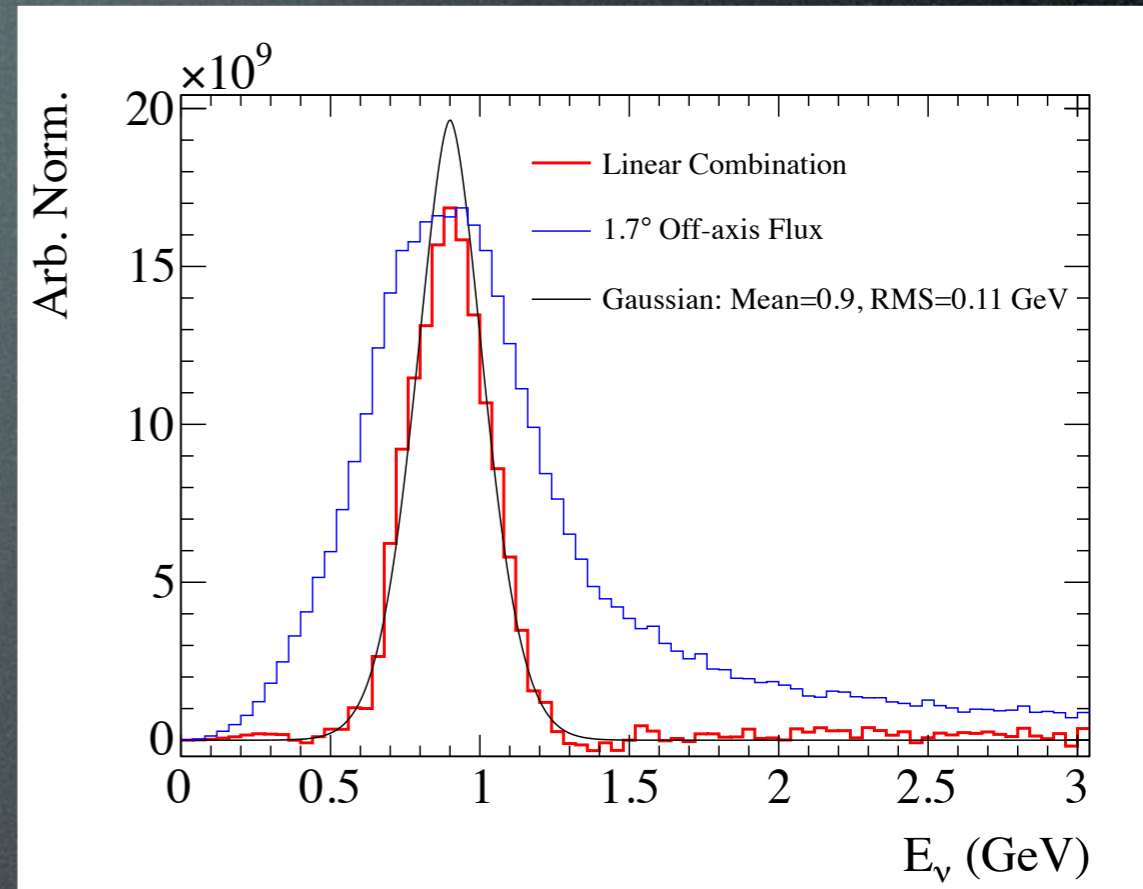

Other Uses of nuPRISM data

Limitations of Near Detectors

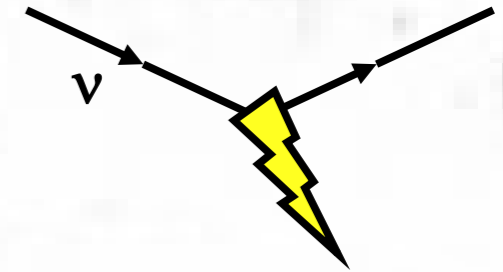

- Limitations of even “perfect” near detectors:
 1. Flux is never identical near and far, because of oscillations if for no other reason.
 2. Near detector has backgrounds to reactions of interest which may not be identical to far detector (see #1).

K. McFarland, Aspen Conference (2013)

Can nuPRISM address this issue as well?

Removing Near/Far Flux Differences

ν -Beam

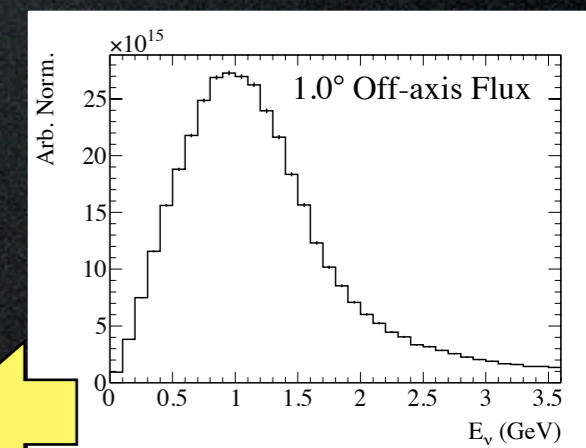
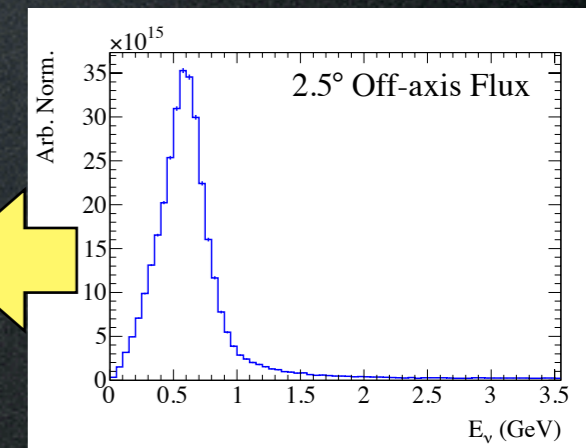
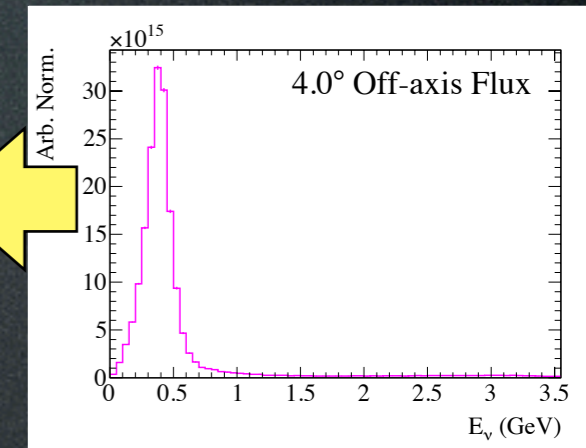
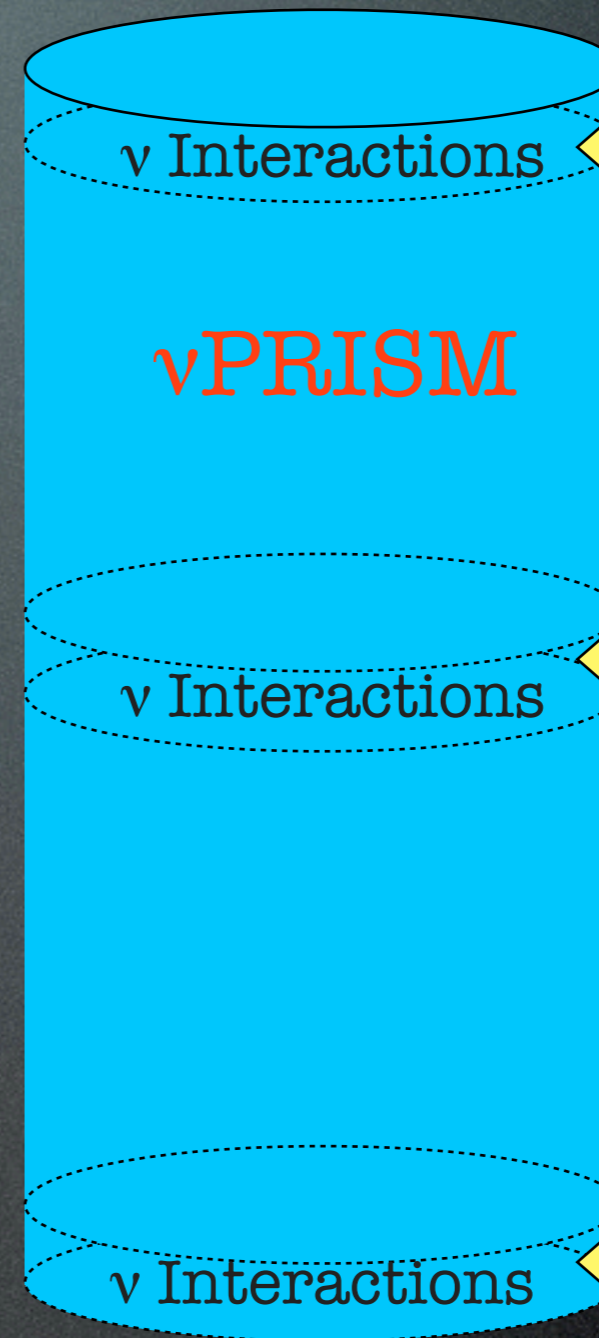
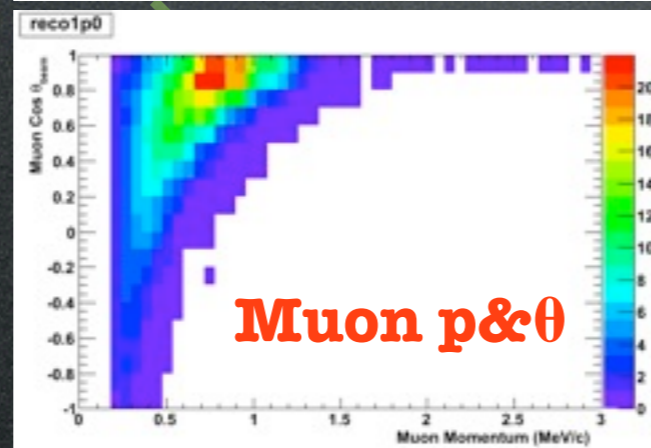
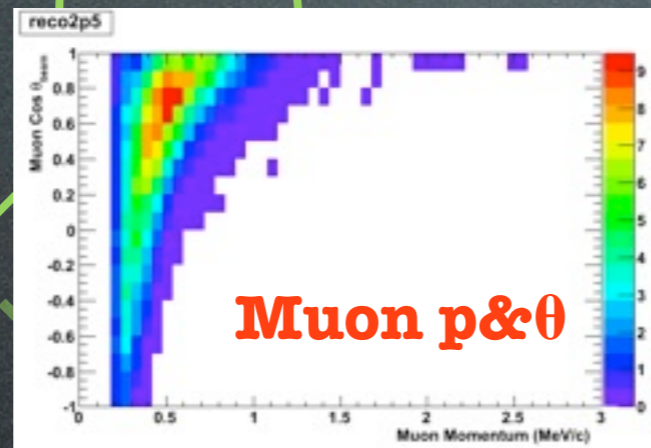
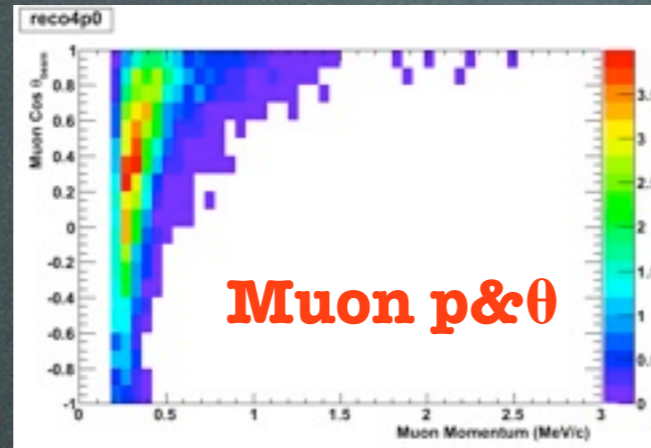

Removing Near/Far Flux Differences

ν -Beam

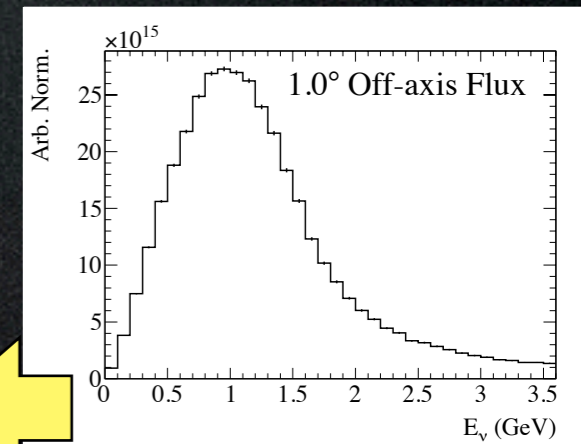
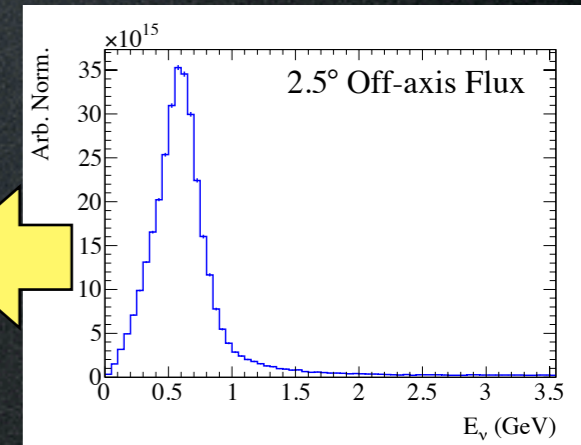
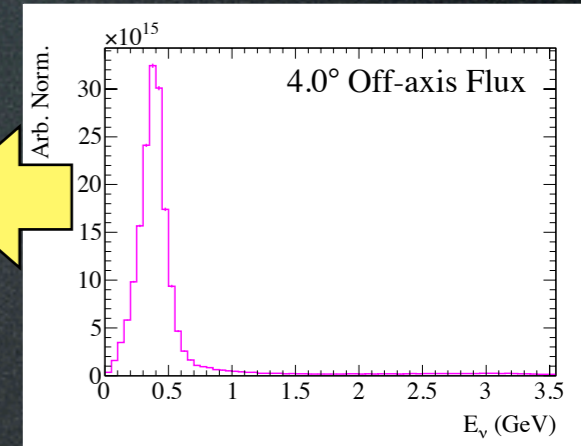
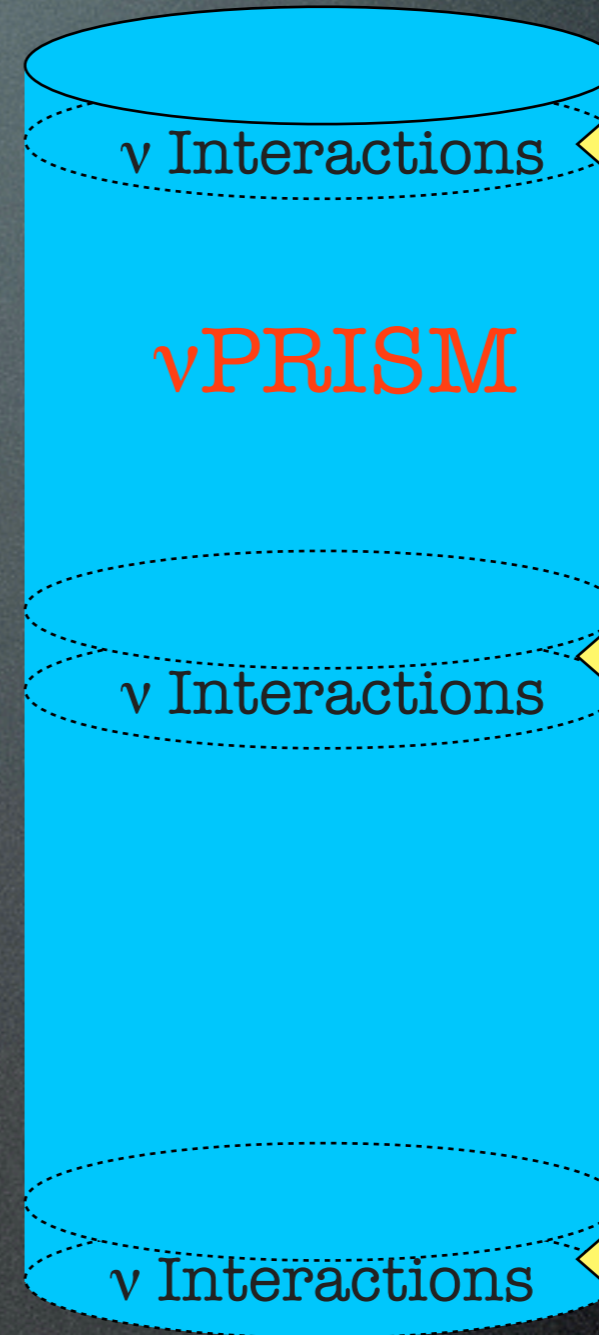
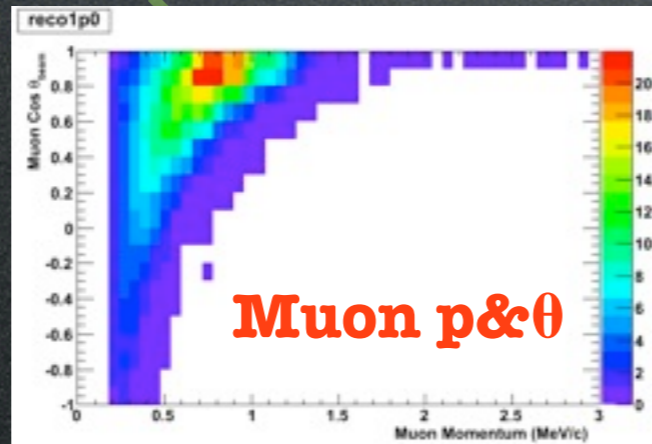
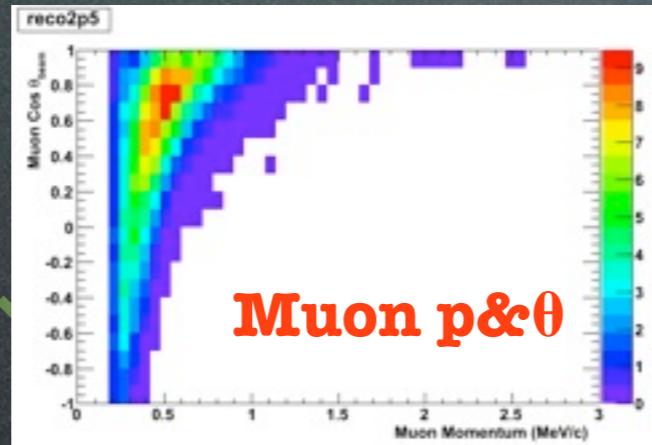
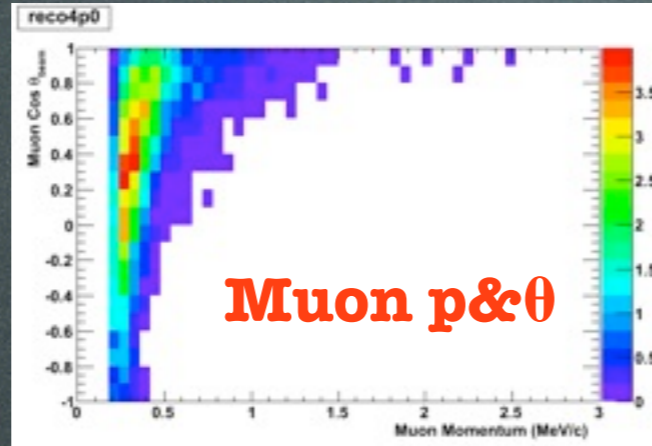

Removing Near/Far Flux Differences

ν -Beam

Take different
linear
combinations!

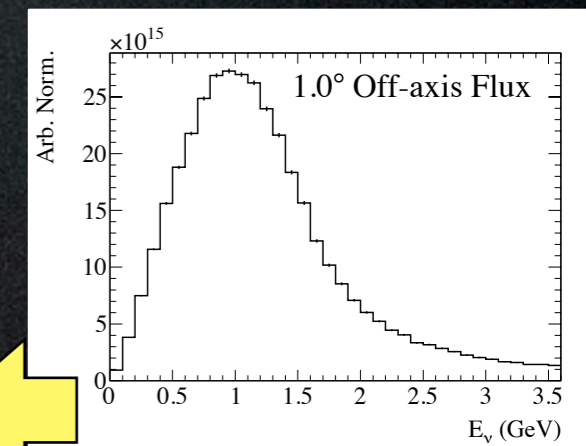
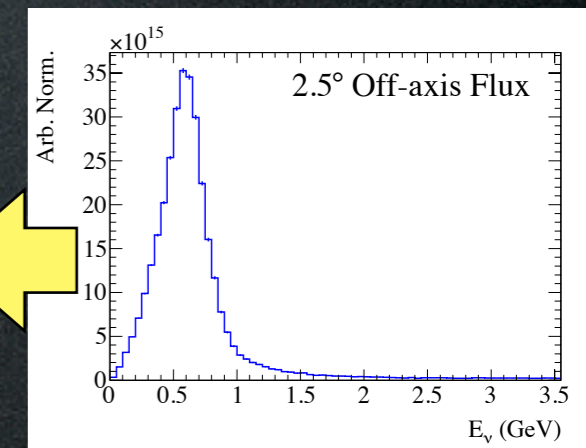
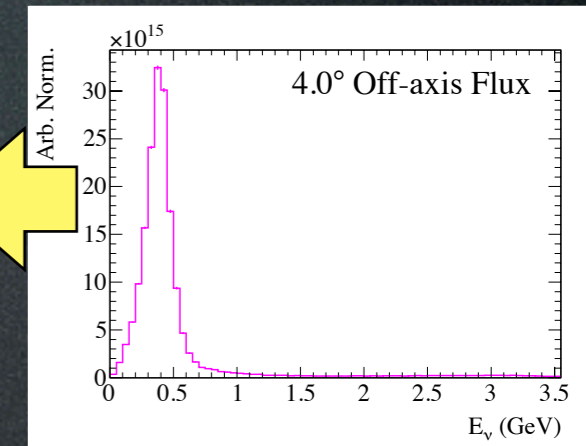
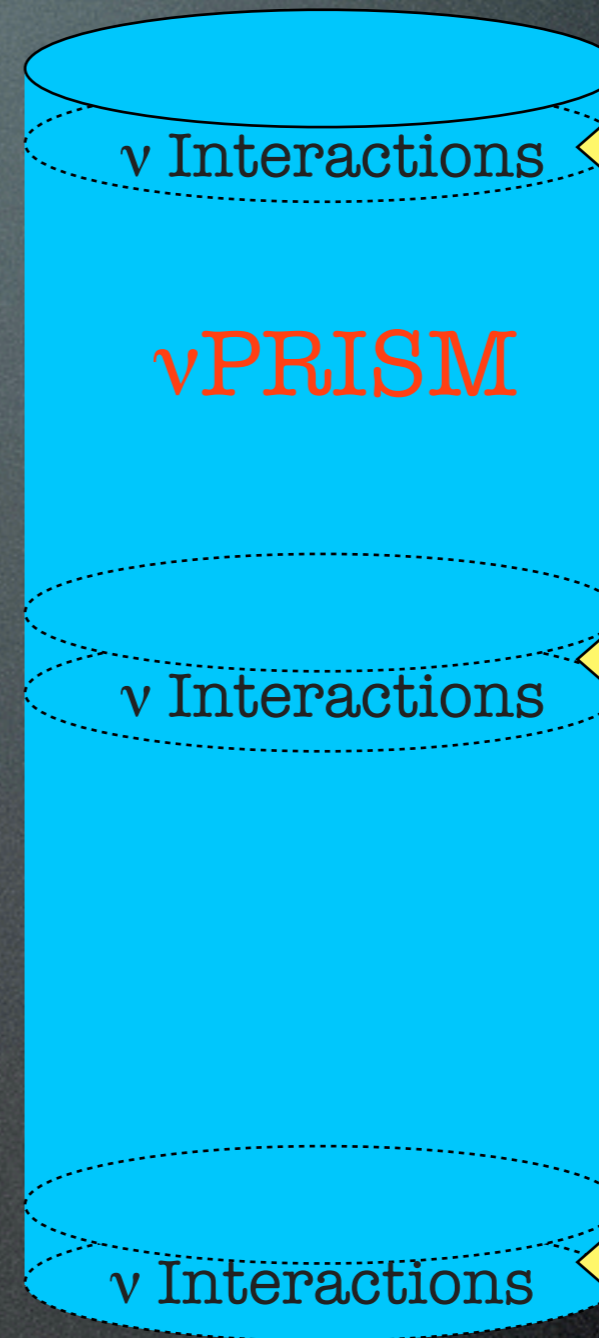
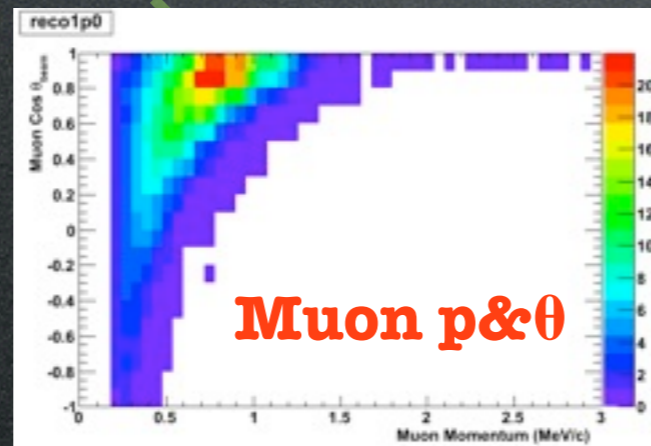
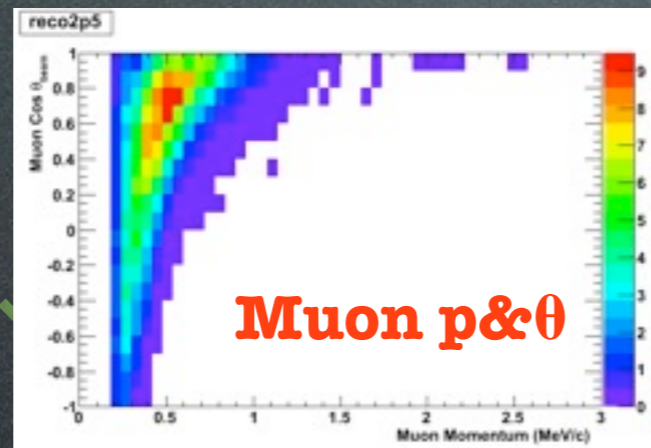
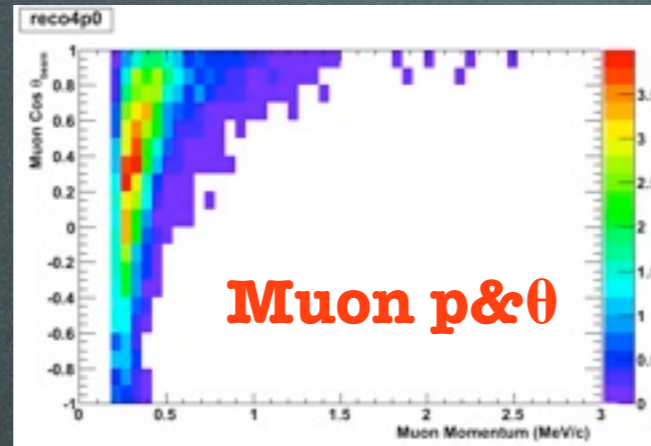

Removing Near/Far Flux Differences

ν -Beam

+1.0*

Take different
linear
combinations!

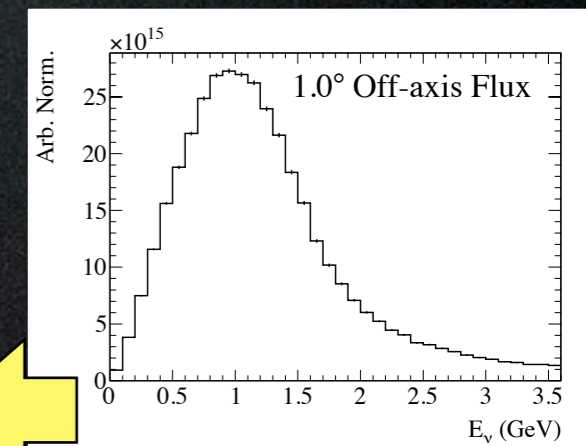
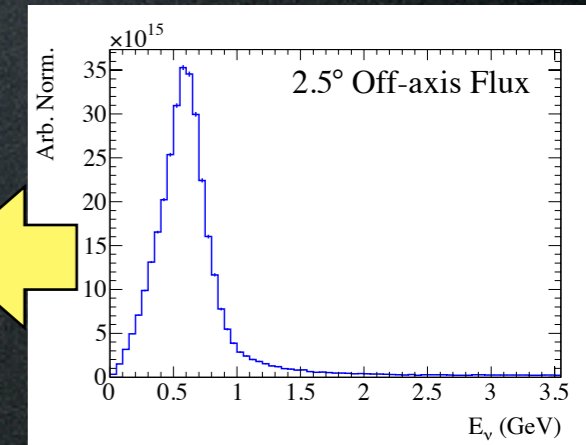
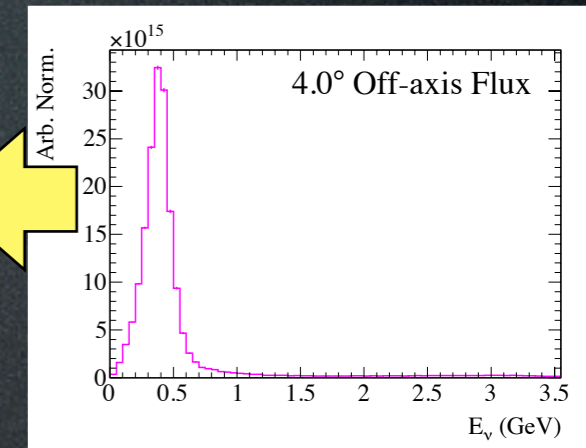
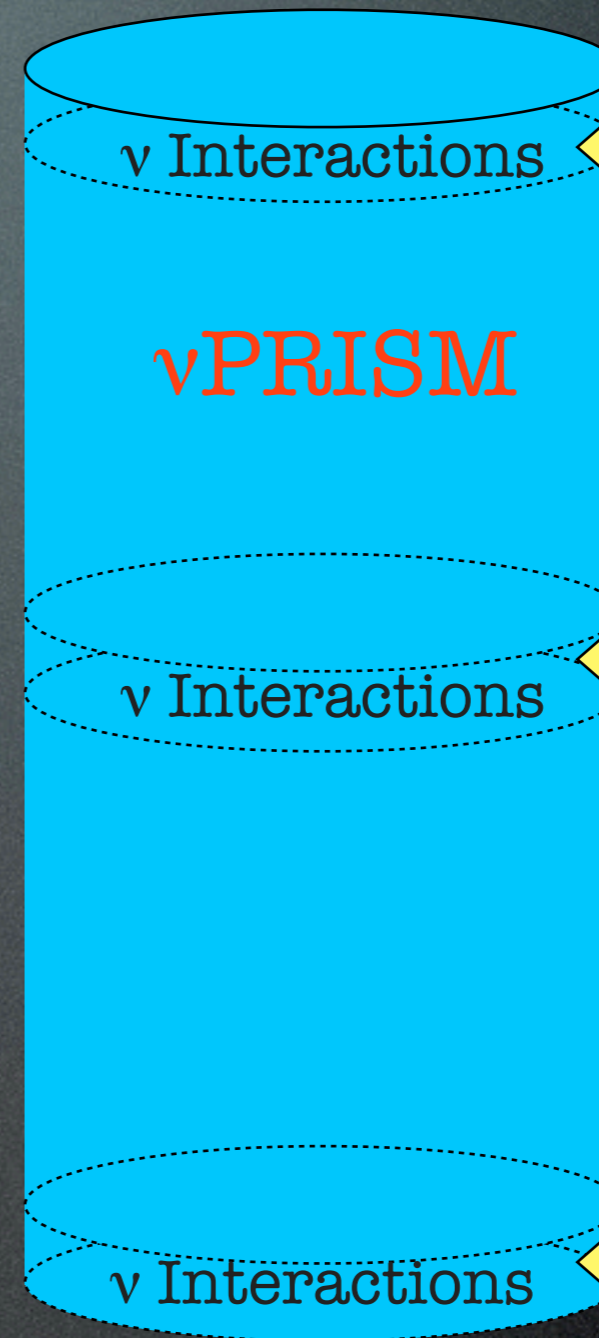
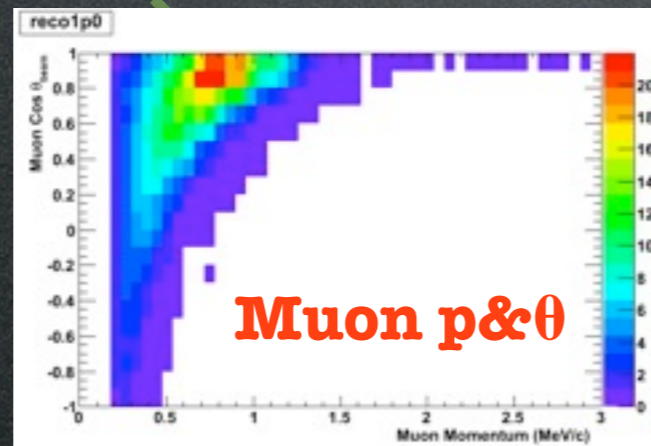
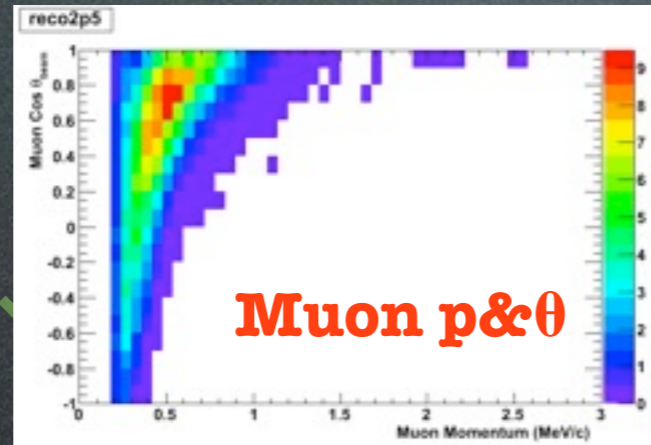
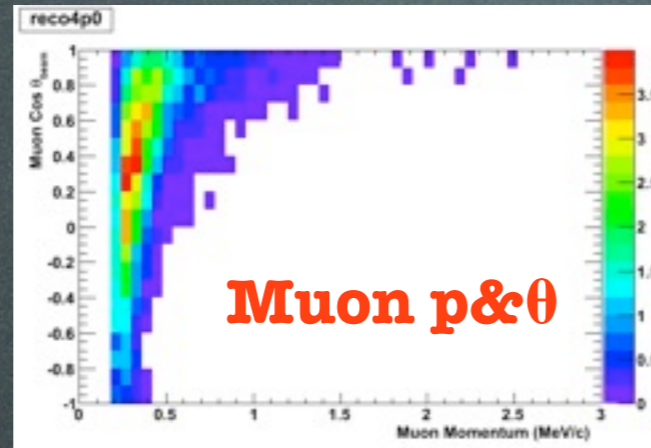

Removing Near/Far Flux Differences

ν -Beam

Take different
linear
combinations!

+1.0*

-0.8*

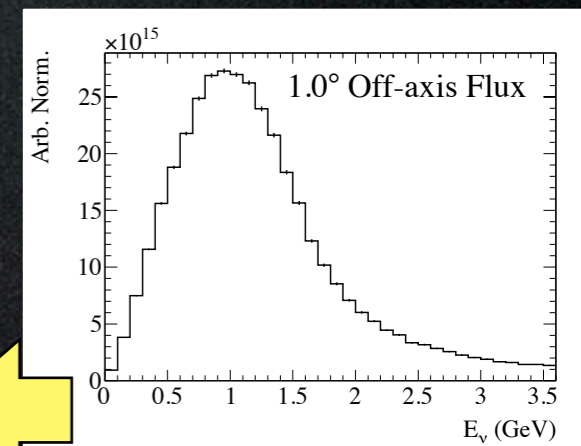
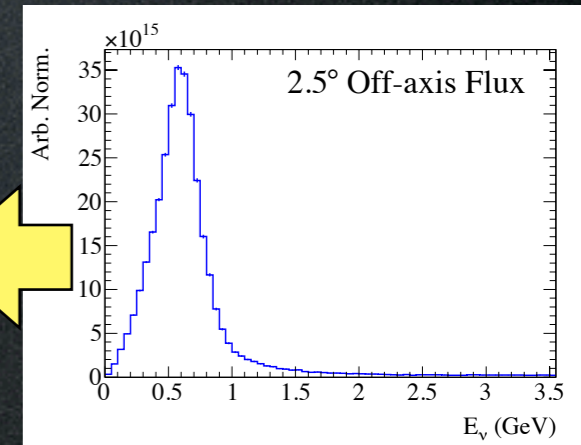
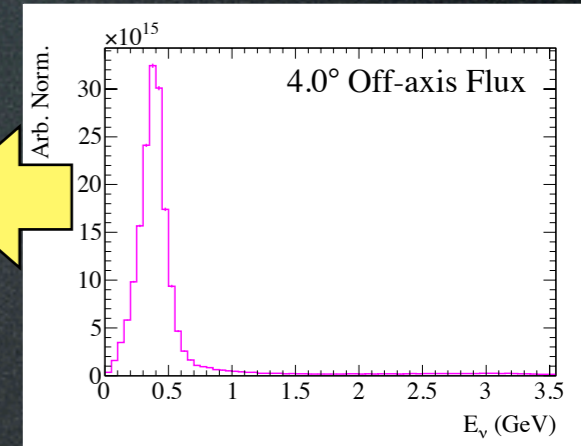
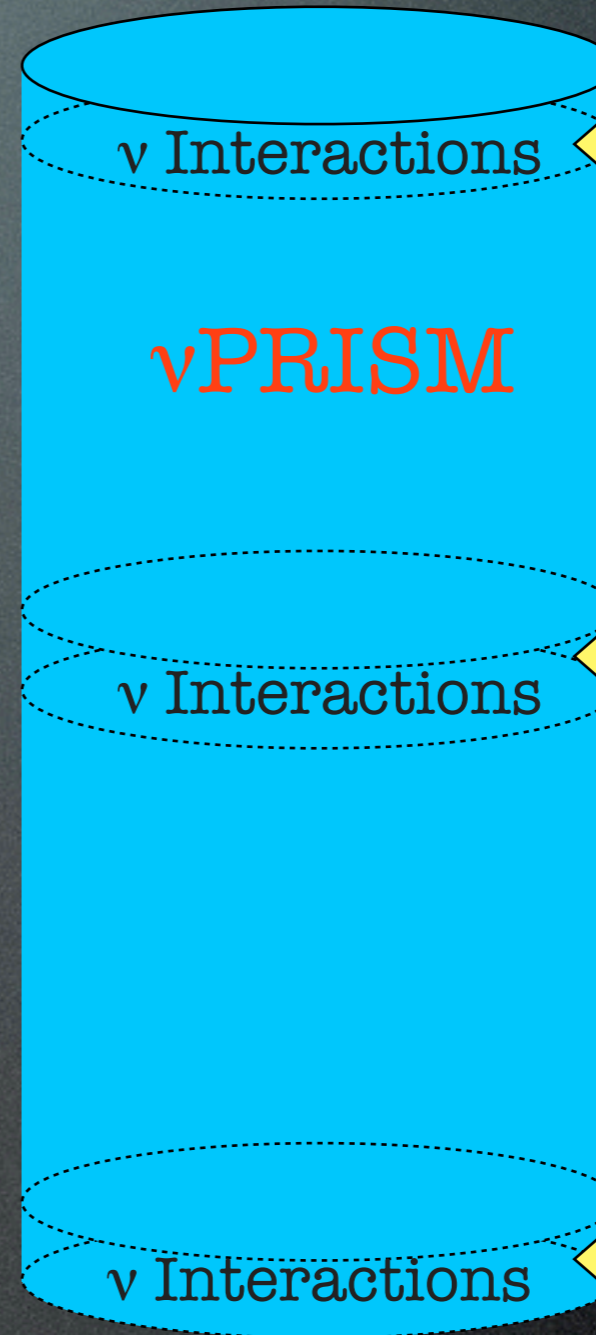
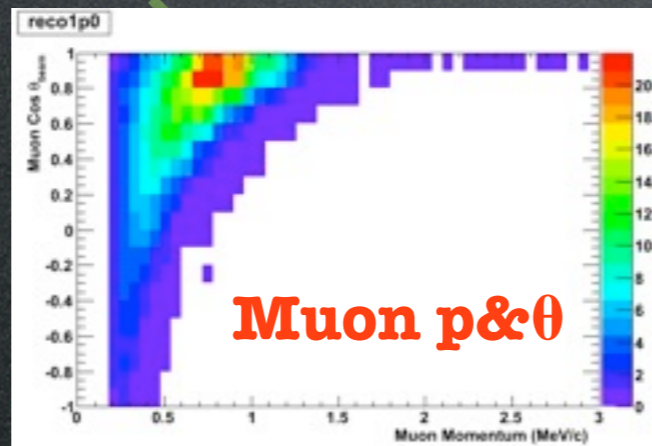
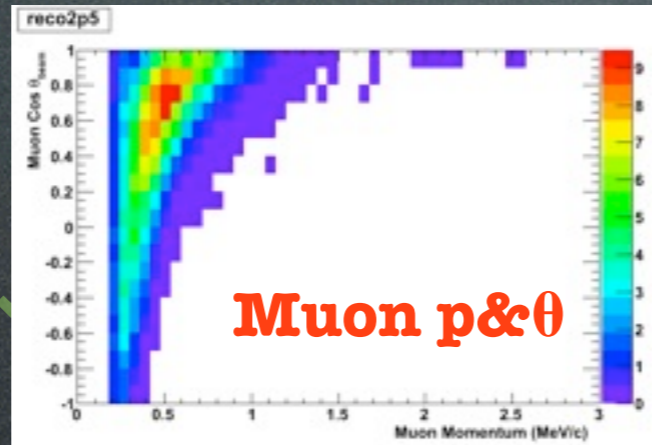
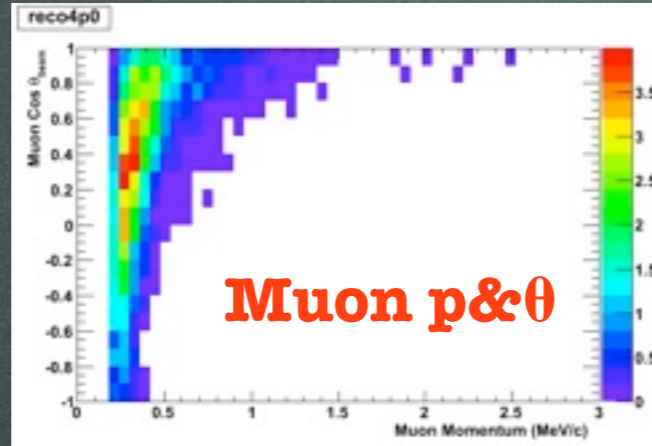

Removing Near/Far Flux Differences

ν -Beam

Take different
linear
combinations!

+1.0*

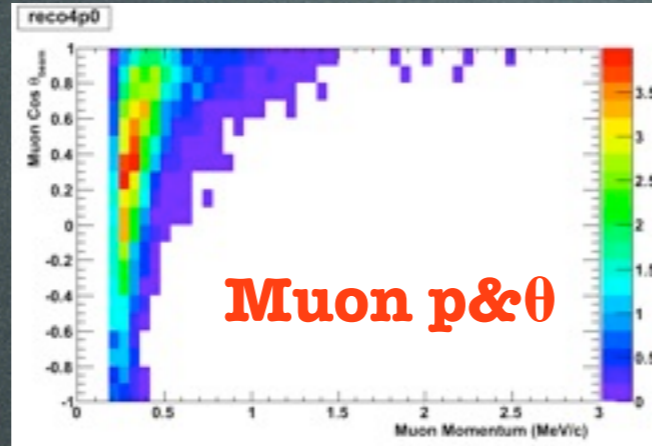

-0.8*

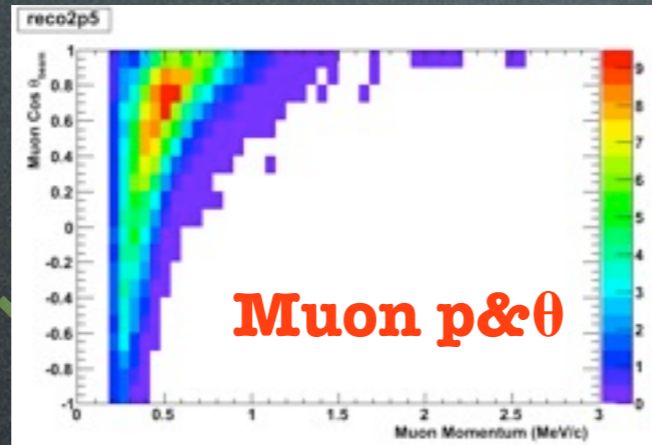

+0.2*

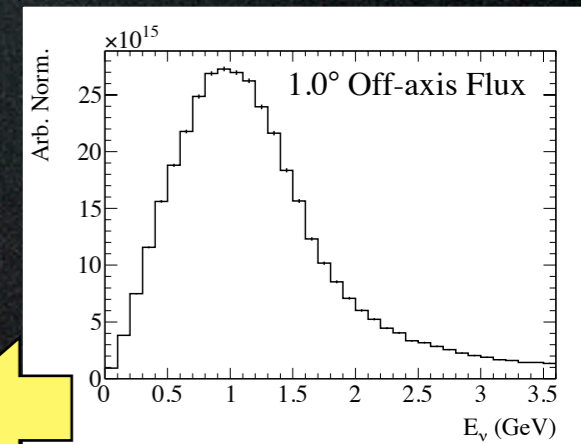
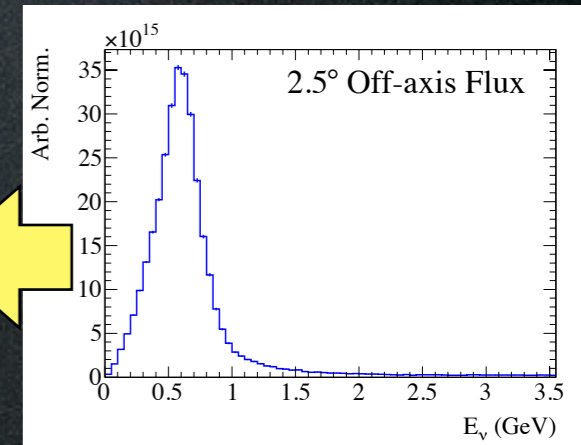
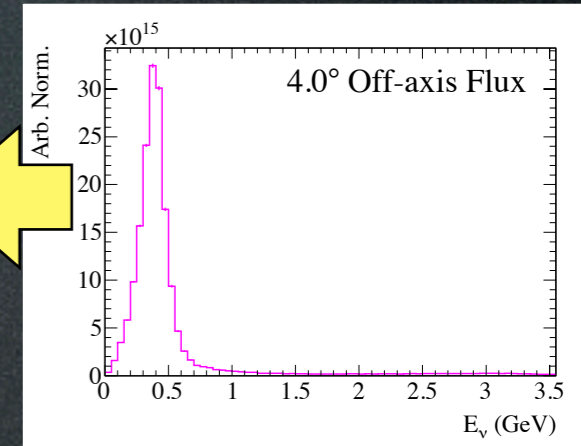
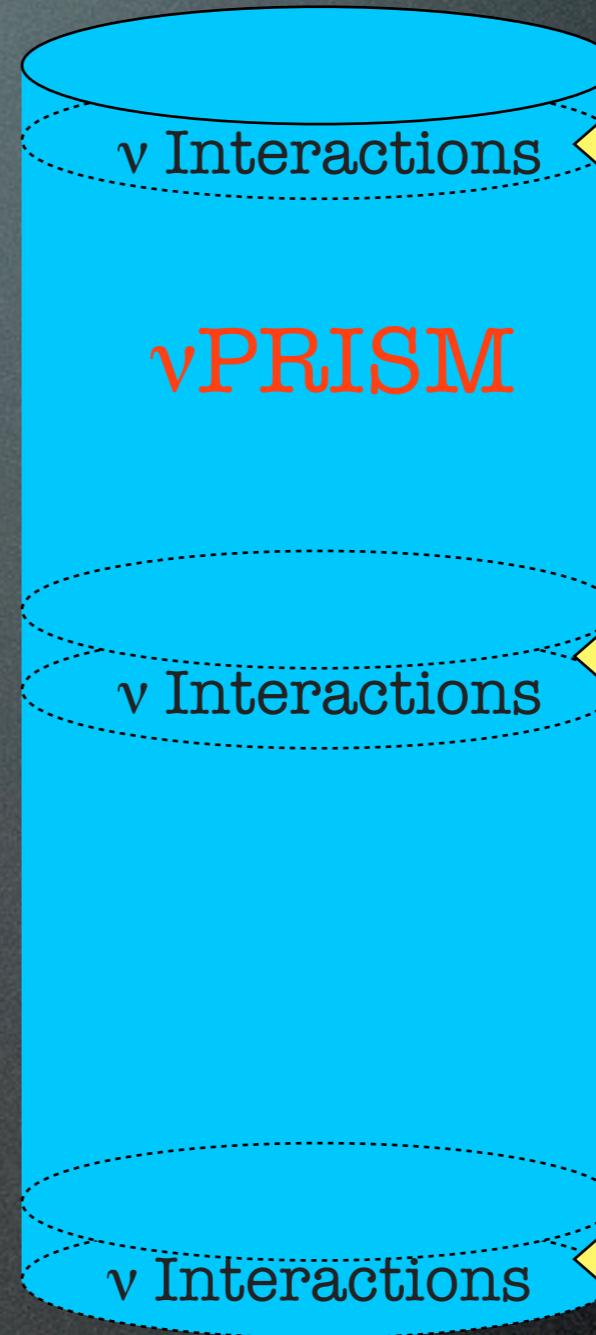
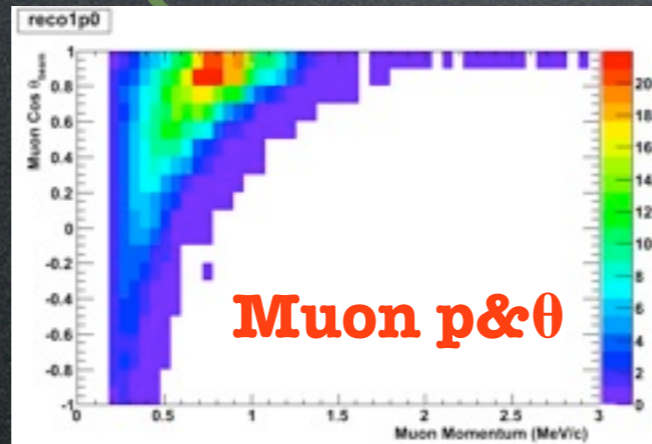

Removing Near/Far Flux Differences

ν -Beam

Take different linear combinations!

+1.0*

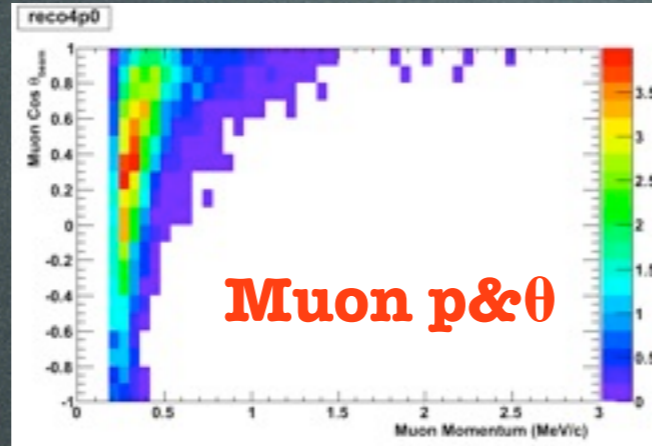

-0.8*

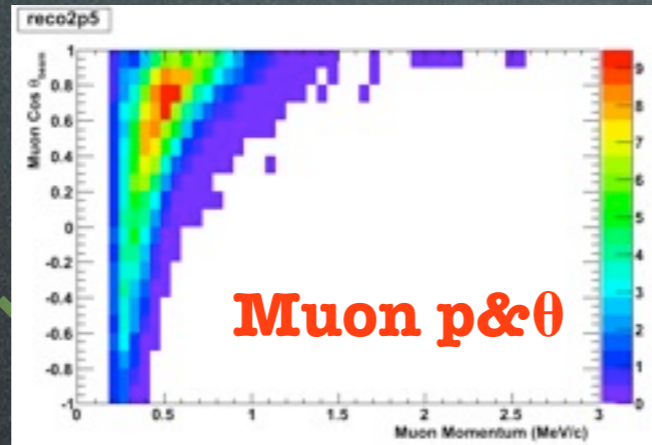

+0.2*

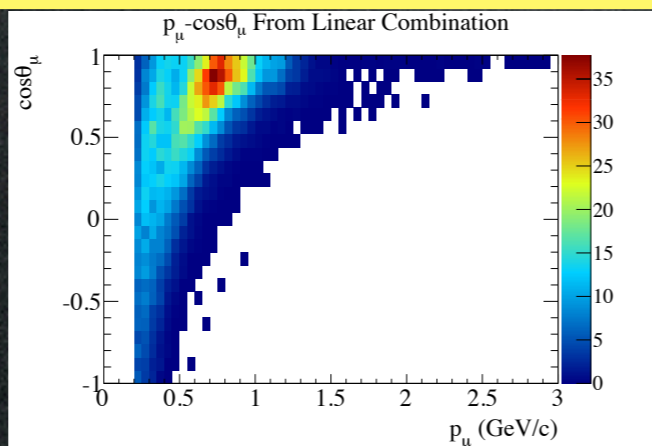
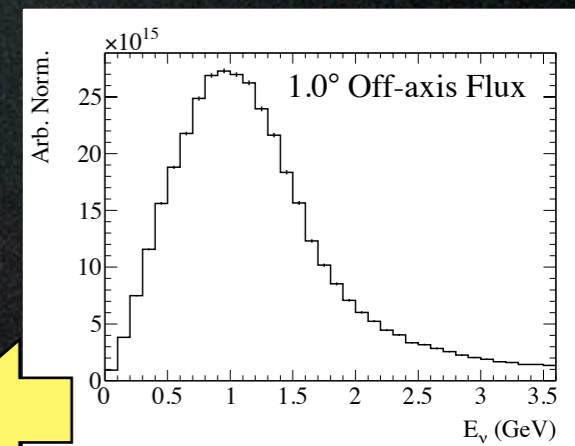
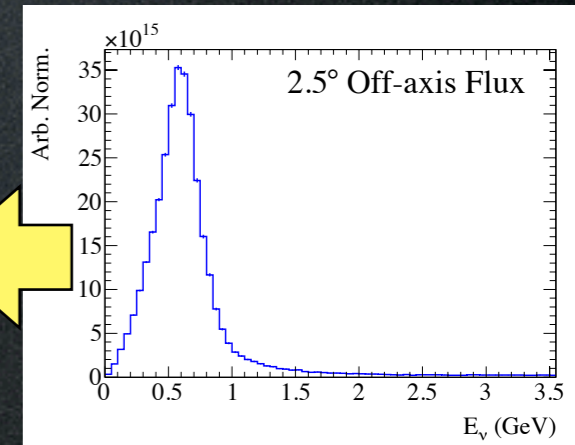
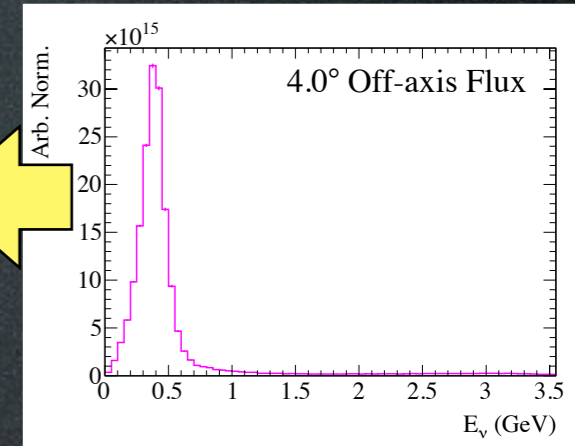
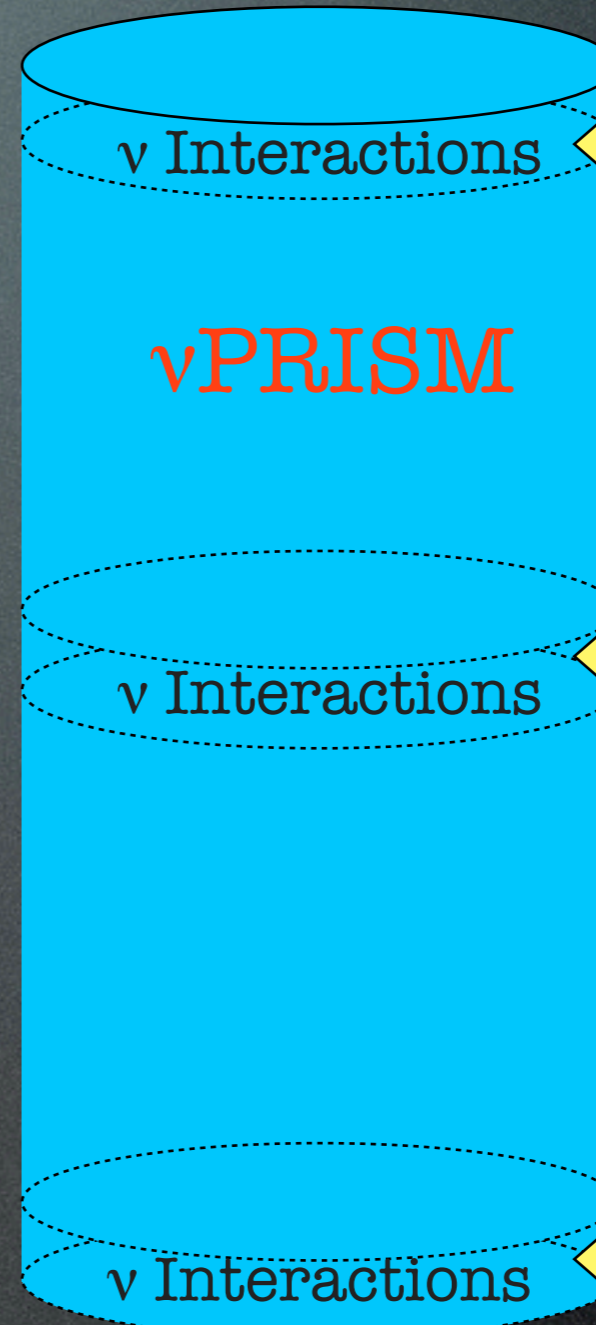
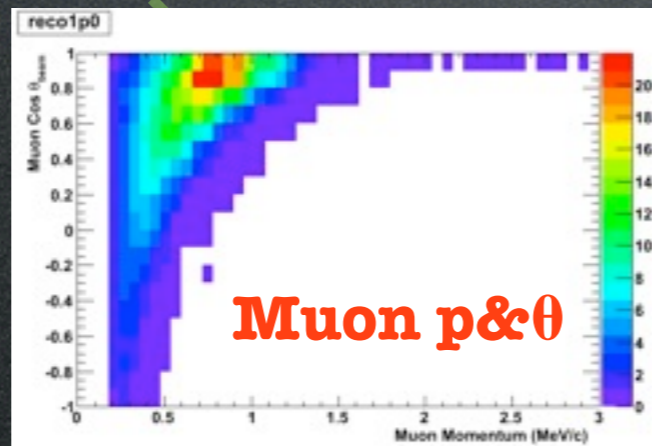

Measured!
Muon p& θ
for Oscillated
SK Flux!

Match Super-K Oscillated Flux

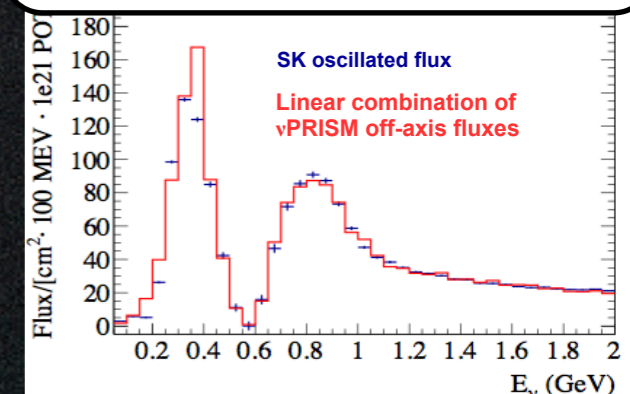

Removing Near/Far Flux Differences

ν -Beam

Take different linear combinations!

This is the procedure used for the **T2K/nuPRISM ν_μ disappearance analysis** (see later slides)

Reproduce Super-K Oscillation Pattern at a Near Detector!

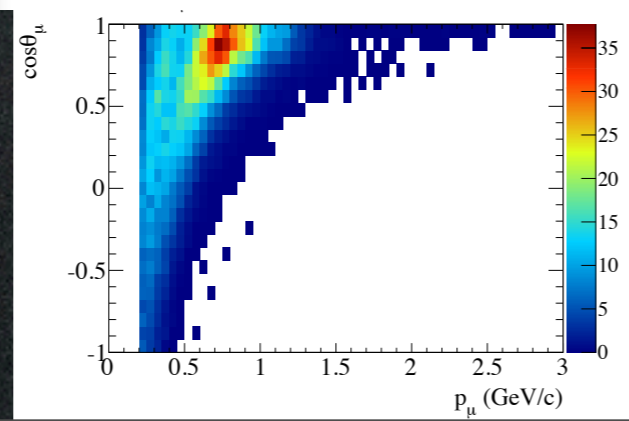
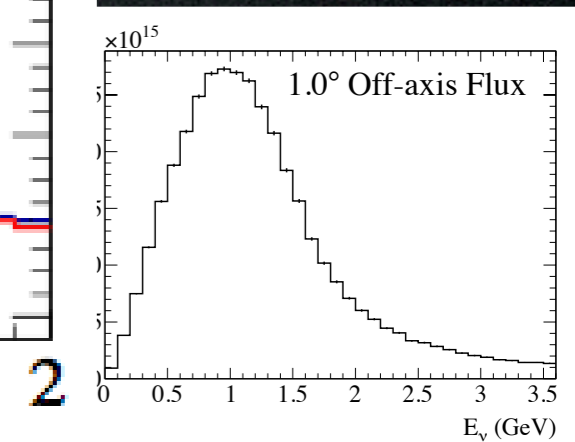
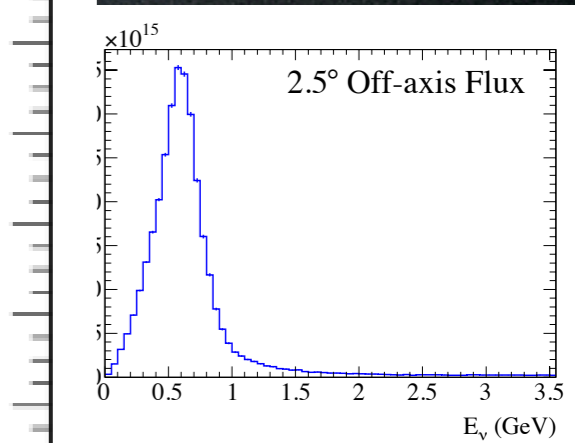
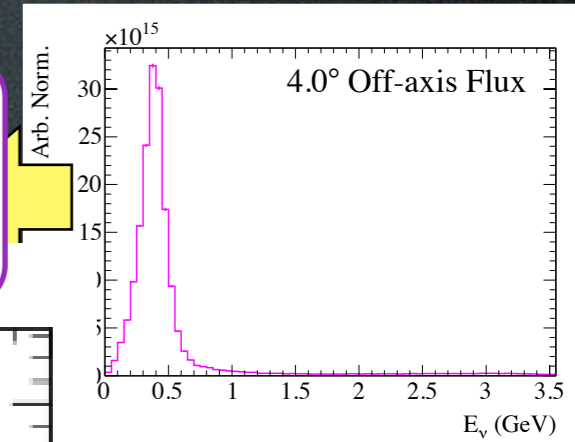
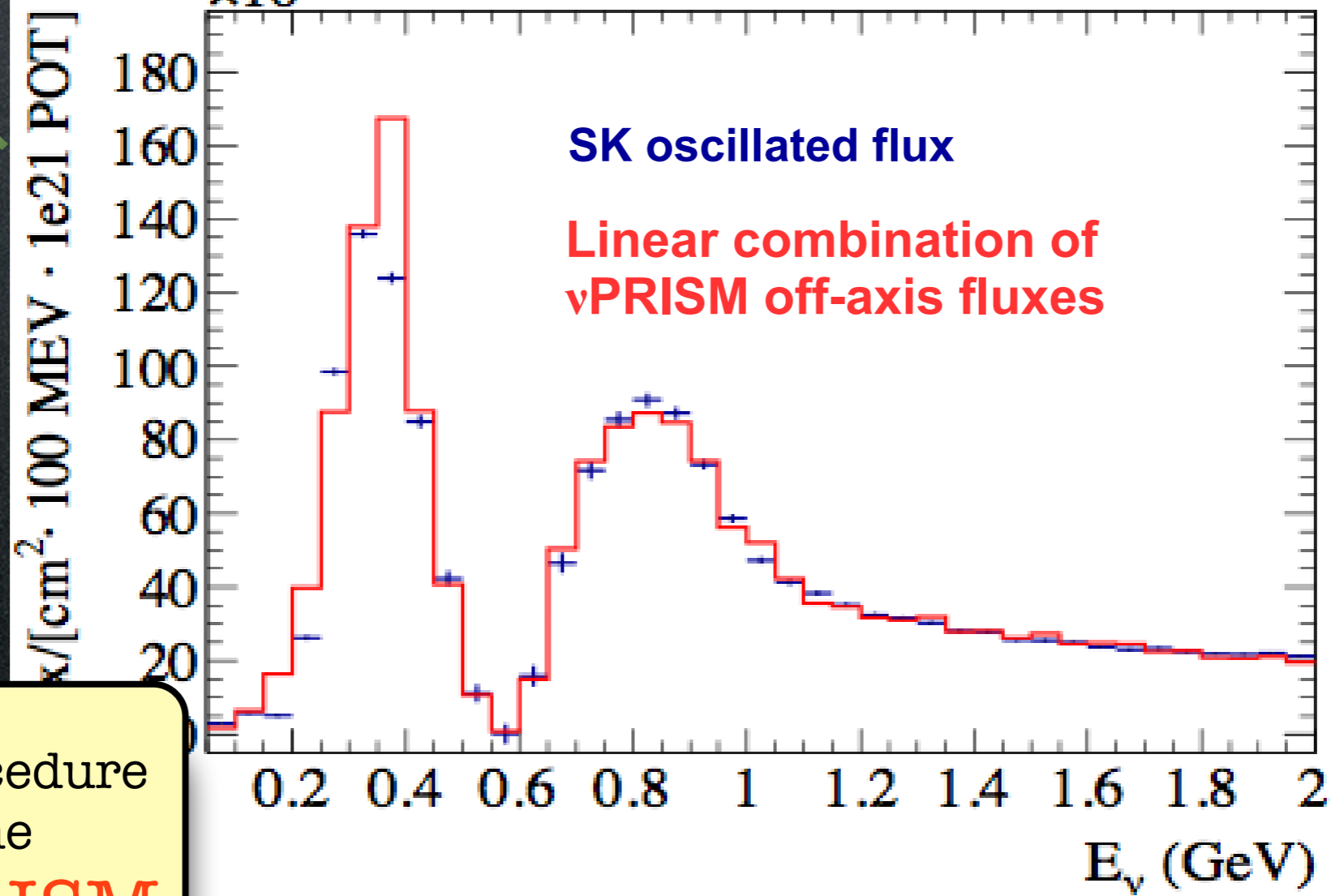

Measured! Muon p& θ for Oscillated SK Flux!

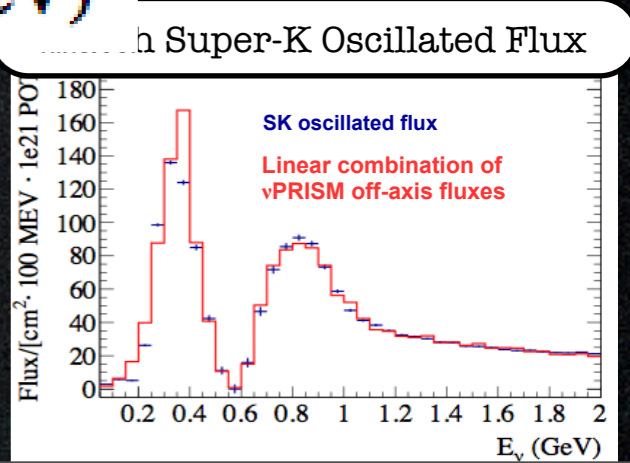

Interpreting Linear Combinations

- After ν PRISM linear combination:
 - CC- ν_μ spectrum should reproduce oscillated far detector spectrum: **Good!**
 - NC- ν_μ backgrounds will also appear “oscillated”: **Bad!**
 - NC events are unaffected by oscillations at Super-K
- **NC events must be subtracted** at both Super-K and nuPRISM
 - Introduces cross section model dependence
- However, **NC backgrounds can be very well measured** using mono-energetic beams
 - Significantly reduces cross section model dependence
- In current analysis (see later slides), NC constraint has not yet been applied
 - **Conservative errors**

ν Energy Spectrum

Flux < 1 GeV is dominated by π^+ decay

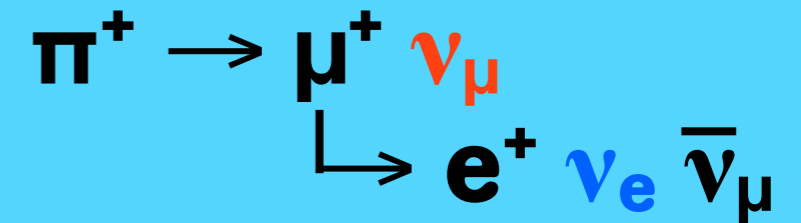

ν_μ produced in 2-body decay

ν_e produced in 3-body decay

ν_μ experience more off-axis affect

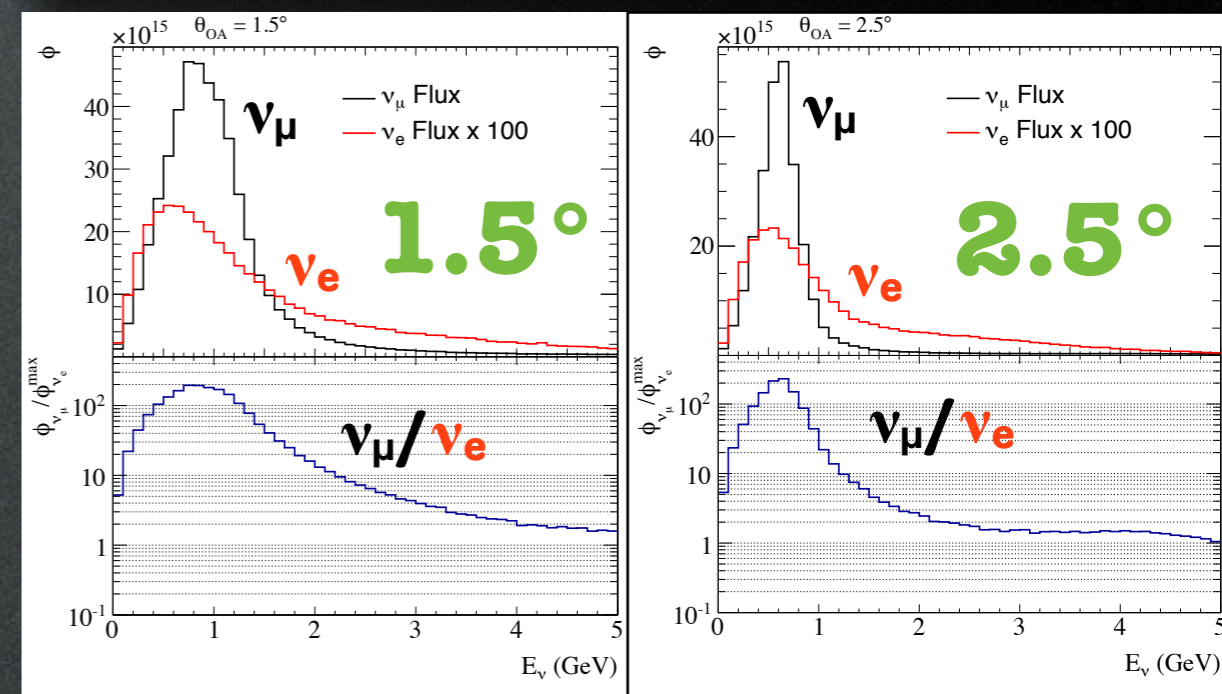

More on Beam Errors

- Haven't we just replaced **unknown cross section errors** with **unknown flux errors**?
 - Yes! But only relative flux errors are important!
 - Cancellation exist between nuPRISM and far detector variations
- **Normalization uncertainties will cancel** in the ν PRISM analysis
 - Cancellations persist, even for the ν PRISM linear combination
 - Shape errors are most important
- For scale, **10% variation** near the dip means **~1% variation** in $\sin^2 2\theta_{23}$
 - Although this region is dominated by feed down
- Full flux variations are reasonable
 - No constraint used (yet) from existing near detector!

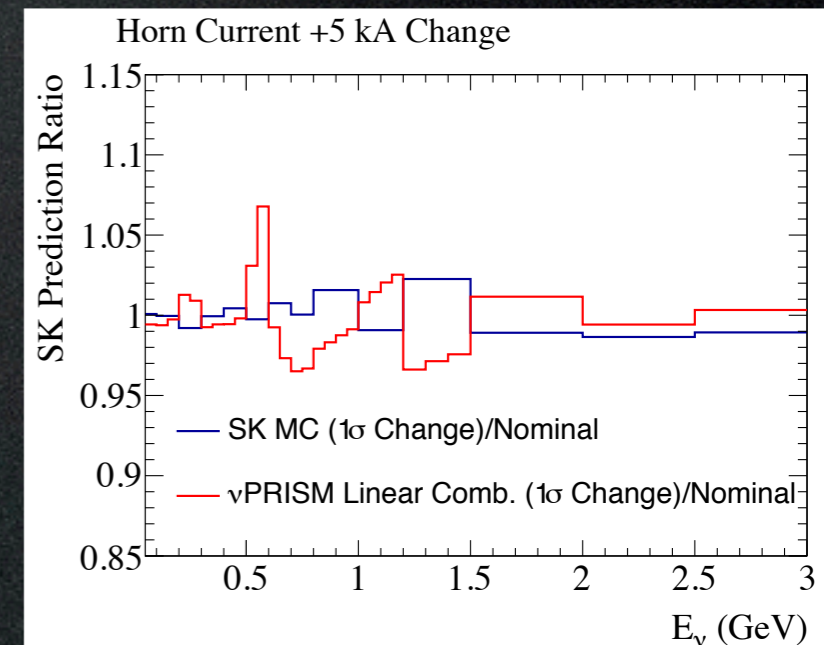
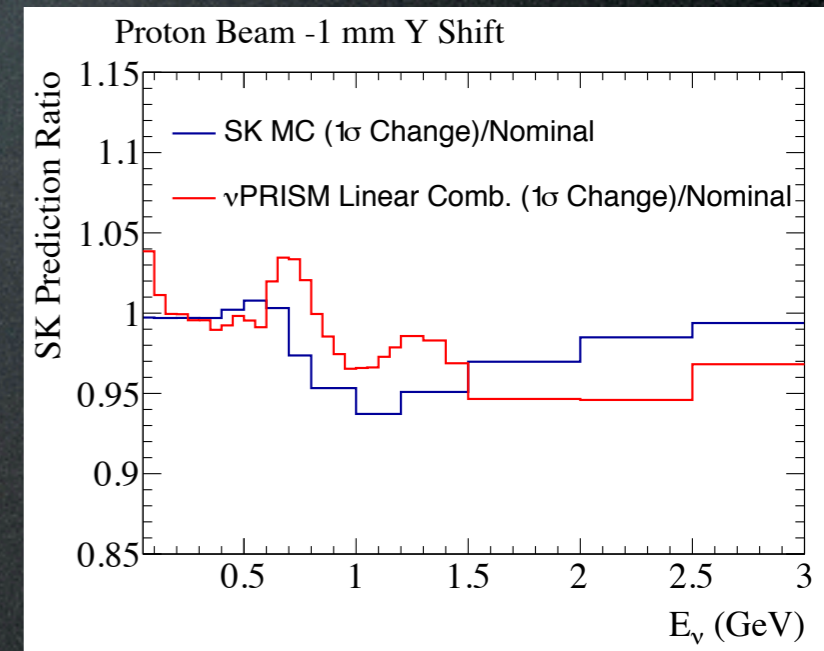
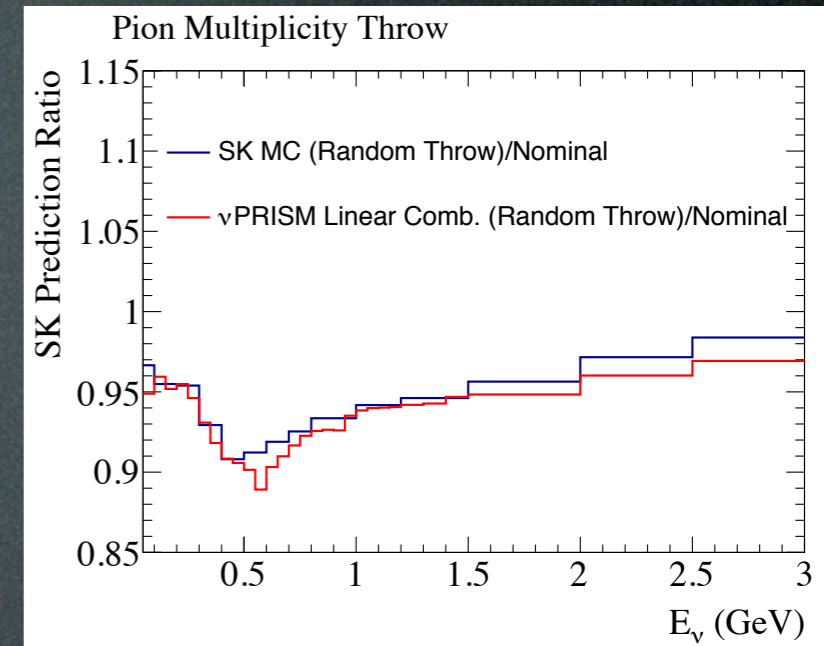

The nuPRISM ν_μ Disappearance Analysis

Most straightforward to perform, and directly impacts sensitivity to CP violation

Reminder: Standard Oscillation Experiment Technique

Observed far detector signal:
1-ring muon events

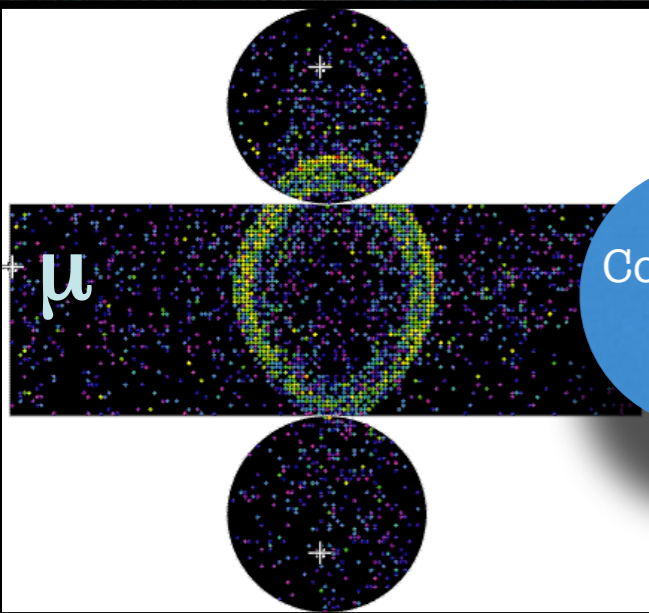

Composed Of:

Nuclear model

CCQE: $\mu^- + p$
(p unobserved)

CC π^+ : $\mu^- + N + \pi^+$
(p, π^+ unobserved)

CCDIS: $\mu^- + X$
(X unobserved)

NC π^+ : $\pi^+ + n$
(π^+ misidentified,
n unobserved)

Predicted by poorly understood models

Parameter	E_ν Range	Nominal	Error	Class
M_A^{QE}	all	1.21 GeV/ c^2	0.45	shape
M_A^{RES}	all	1.41 GeV/ c^2	0.11	shape
p_F^{12C}	all	217 MeV/ c	30	shape
E_B^{12C}	all	25 MeV	9	shape
SF 12C	all	0 (off)	1 (on)	shape
CC Other shape ND280	all	0.0	0.40	shape
Pion-less Δ Decay	all	0.0	0.2	shape
CCQE E1	$0 < E_\nu < 1.5$	1.0	0.11	norm
CCQE E2	$1.5 < E_\nu < 3.5$	1.0	0.30	norm
CCQE E3	$E_\nu > 3.5$	1.0	0.30	norm
CC1 π E1	$0 < E_\nu < 2.5$	1.15	0.43	norm
CC1 π E2	$E_\nu > 2.5$	1.0	0.40	norm
CC Coh	all	1.0	1.0	norm
NC1 π^0	all	0.96	0.43	norm
NC 1 π^\pm	all	1.0	0.3	norm
NC Coh	all	1.0	0.3	norm
NC other	all	1.0	0.30	norm
ν_μ/ν_e	all	1.0	0.03	norm
$\nu/\bar{\nu}$	all	1.0	0.40	norm

Simultaneously constrain flux and cross section parameters with a near detector

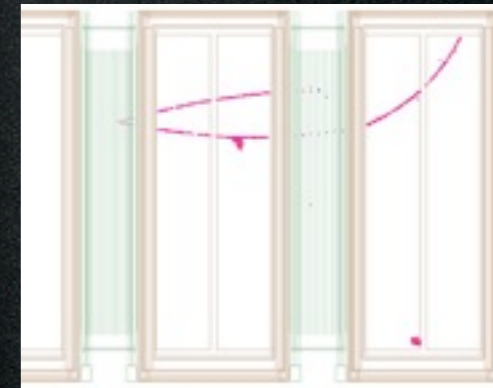

Often with a different nuclear target and phase space

Fluxes are also quite different:

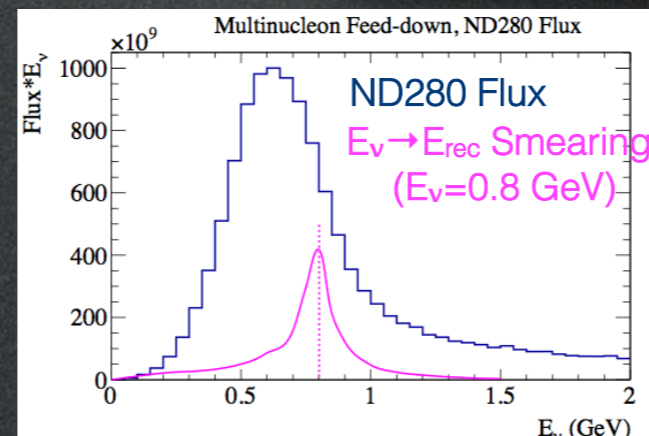
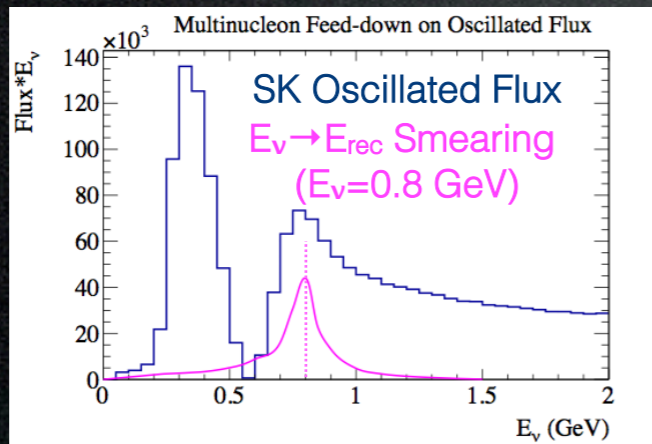

Very difficult to deconvolve!

nuPRISM Technique

- Flux is now the same at the near and far detector
 - **Can just measure observed muon p vs θ for any oscillated flux**
- Same signal selection as used at Super-K
 - Single, muon-like ring
- **Signal events** are defined as **all true single-ring, muon-like events**
 - A muon above Cherenkov threshold
 - All other particles below Cherenkov threshold
 - Signal includes CCQE, multi-nucleon, $CC\pi^+$, etc.
- **No need to make individual measurements of each process and extrapolate to T2K flux**

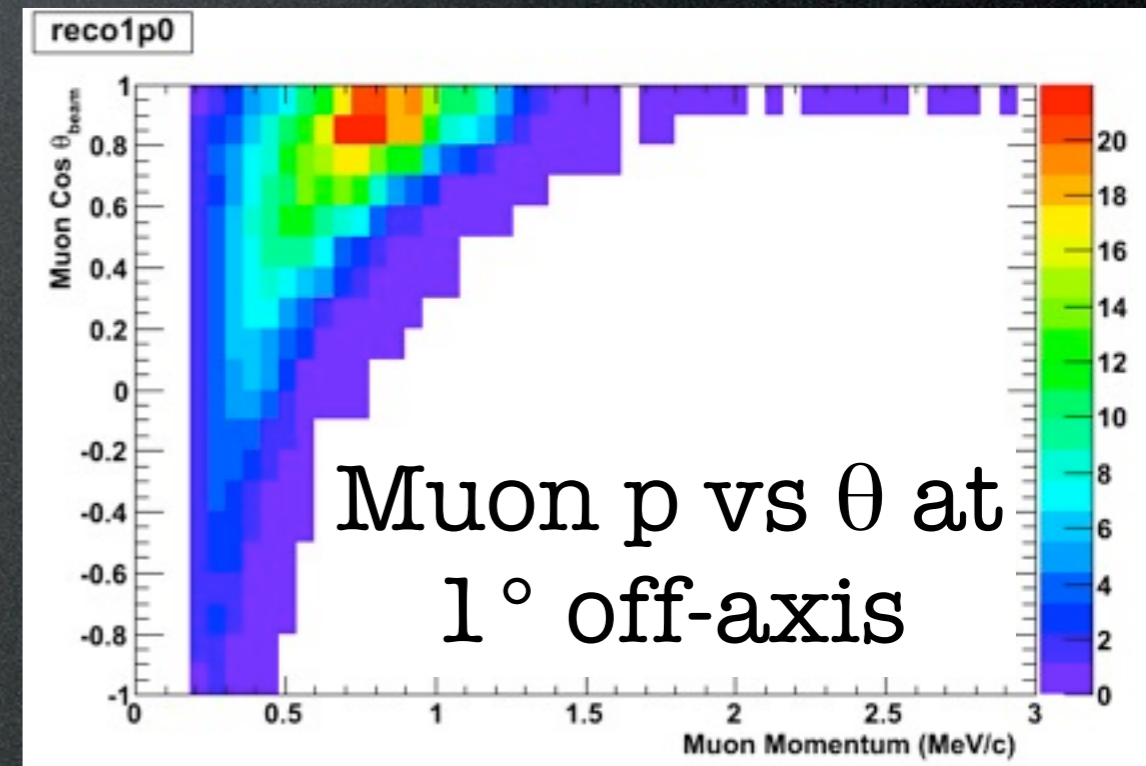
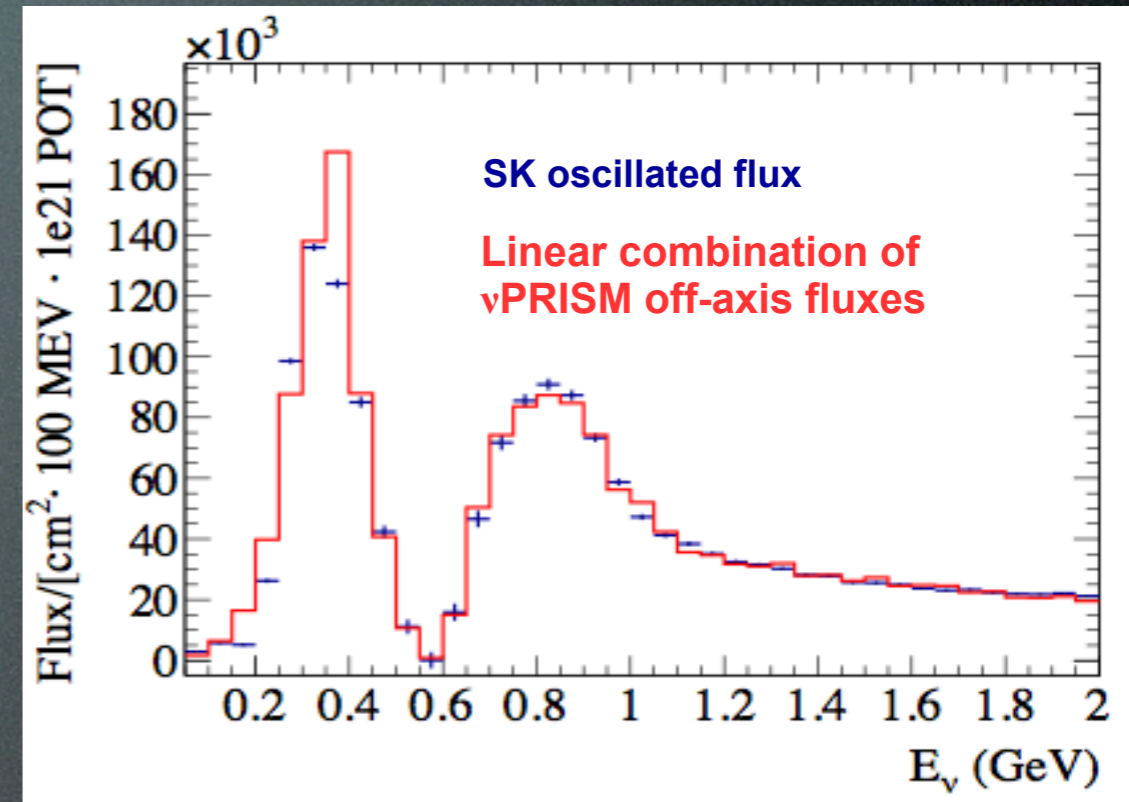

Reminder: Analysis Concept

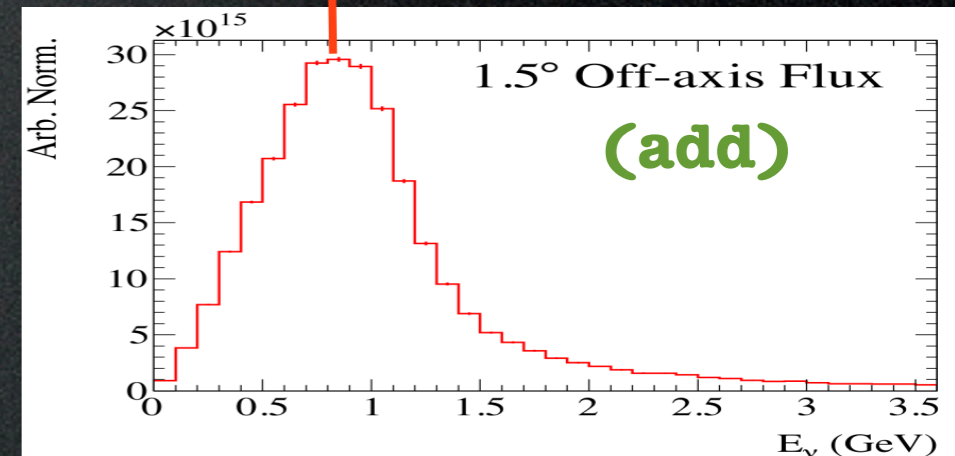
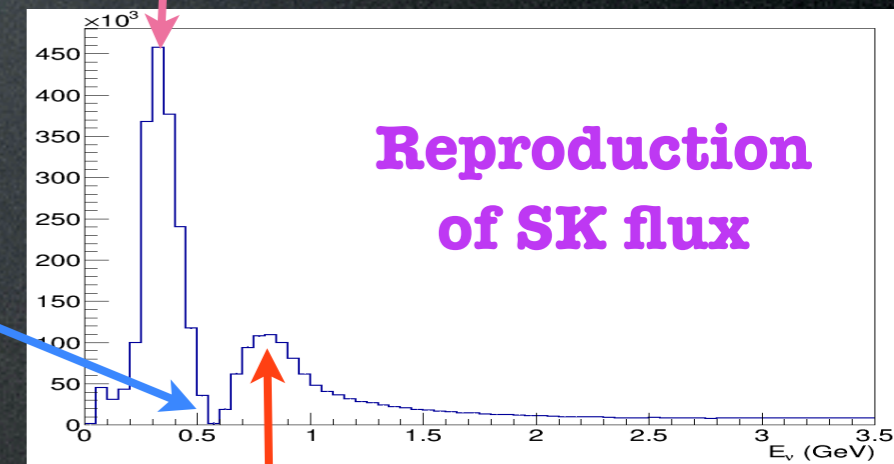
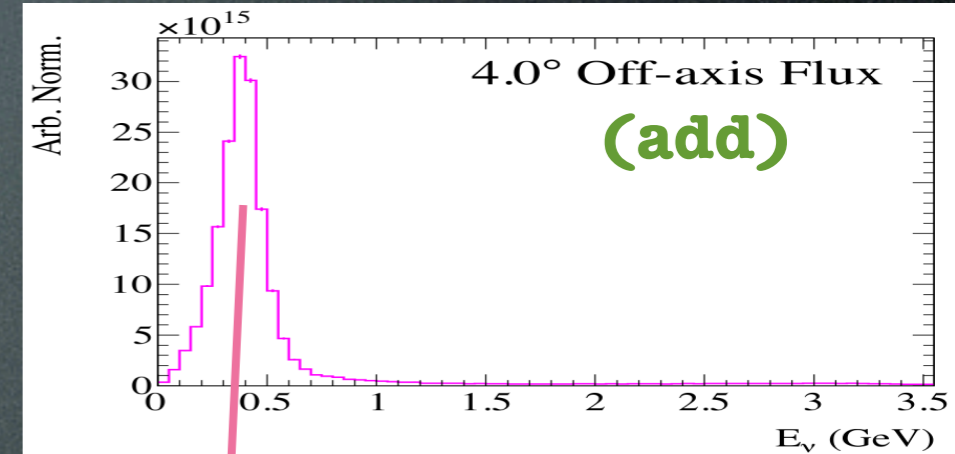
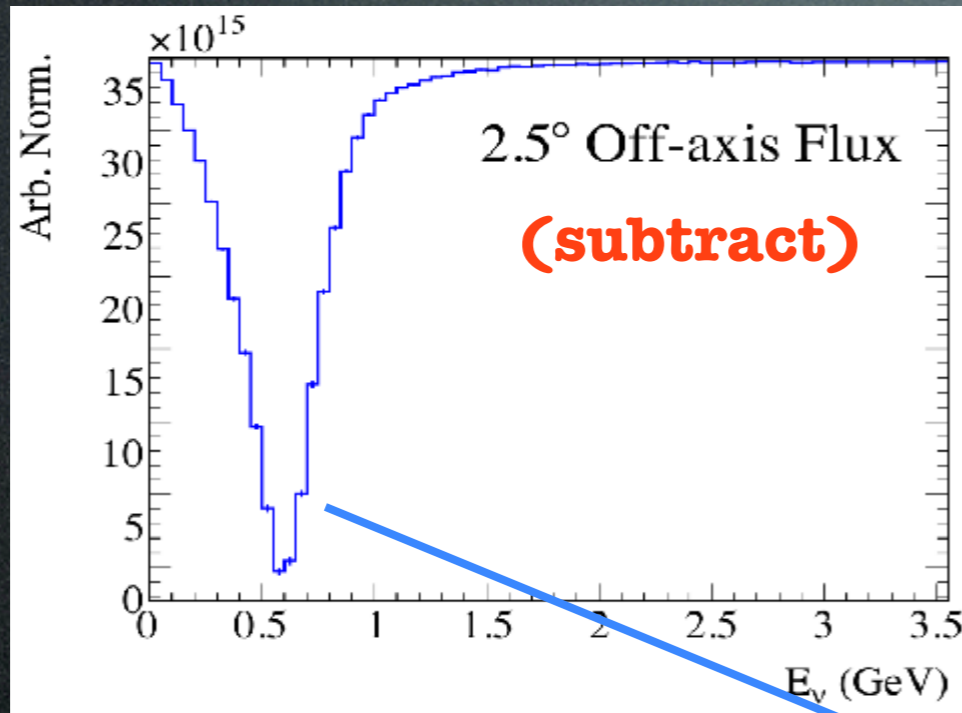

- Different slices of nuPRISM are combined to reproduce an oscillated SK flux
 - **Flux only!** No cross sections or detector response at this point
- For simplicity, only 3 slices are shown here
 - The default analysis **uses 60 slices**

Flux Fit

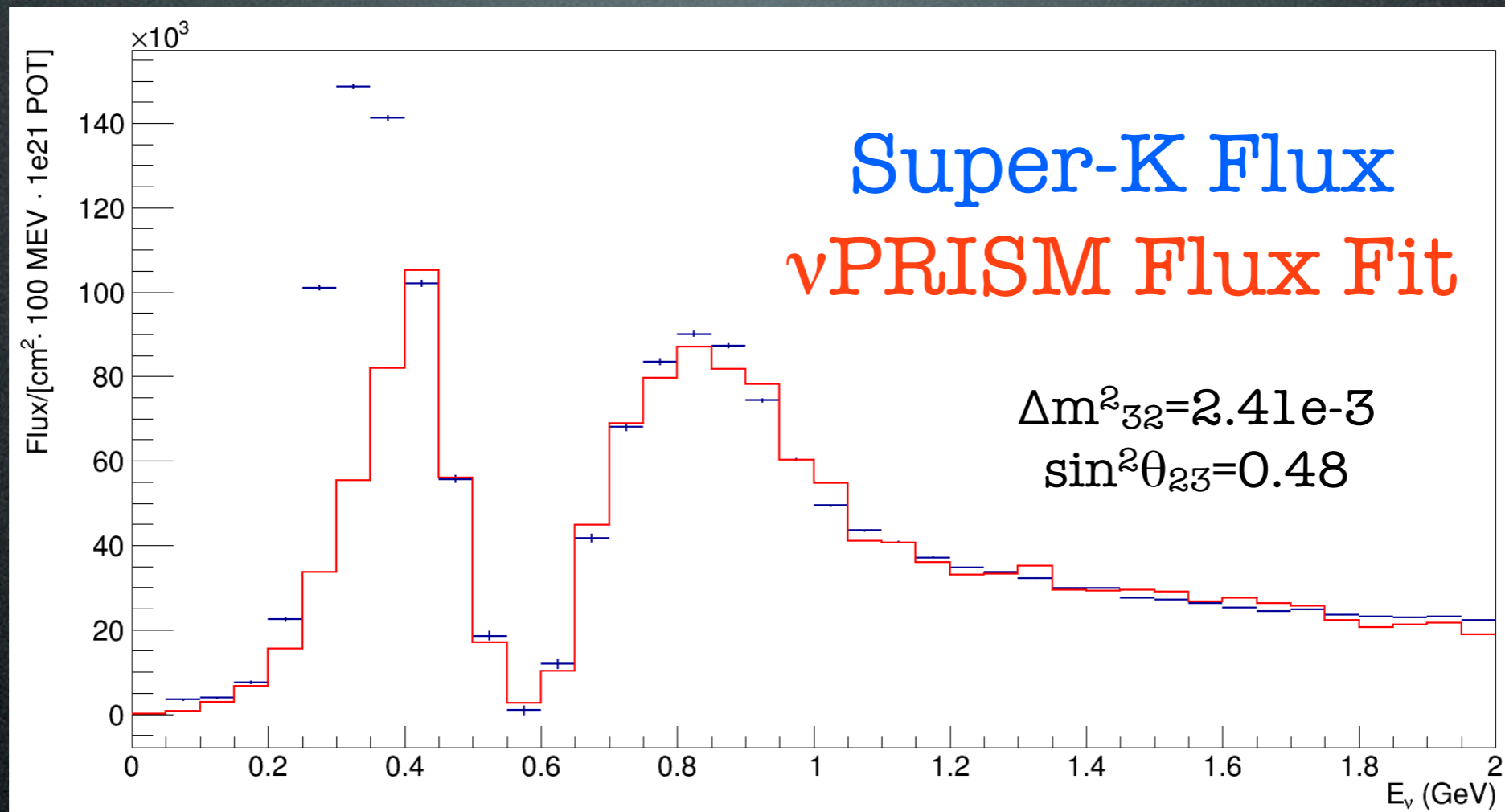

- Fit for coefficients of 60 off-axis ν PRISM slices to match a chosen Super-K oscillated spectrum
 - Fit between 400 MeV and 2 GeV
 - **Repeat this fit for every set of oscillation parameters**
- Notice disagreement at low energy
 - The most off-axis flux (4°) peaks at 380 MeV, so difficult to fit lower energies
 - Could extend detector further off-axis, but the low energy region is not very important to extract oscillation physics (e.g. nuclear feed-down not an issue)

Statistical Uncertainties

- Linear combinations can cause very large fractional uncertainties
 - e.g. a simple statistical subtraction
 - $\sqrt{(N_1+N_2) / (N_1-N_2)}$
- A naive fit of 30 ν PRISM slices to an SK flux gives **nearly 100% errors!**
- But, many non-unique solutions exist for ν PRISM flux weights

Covariance Matrix

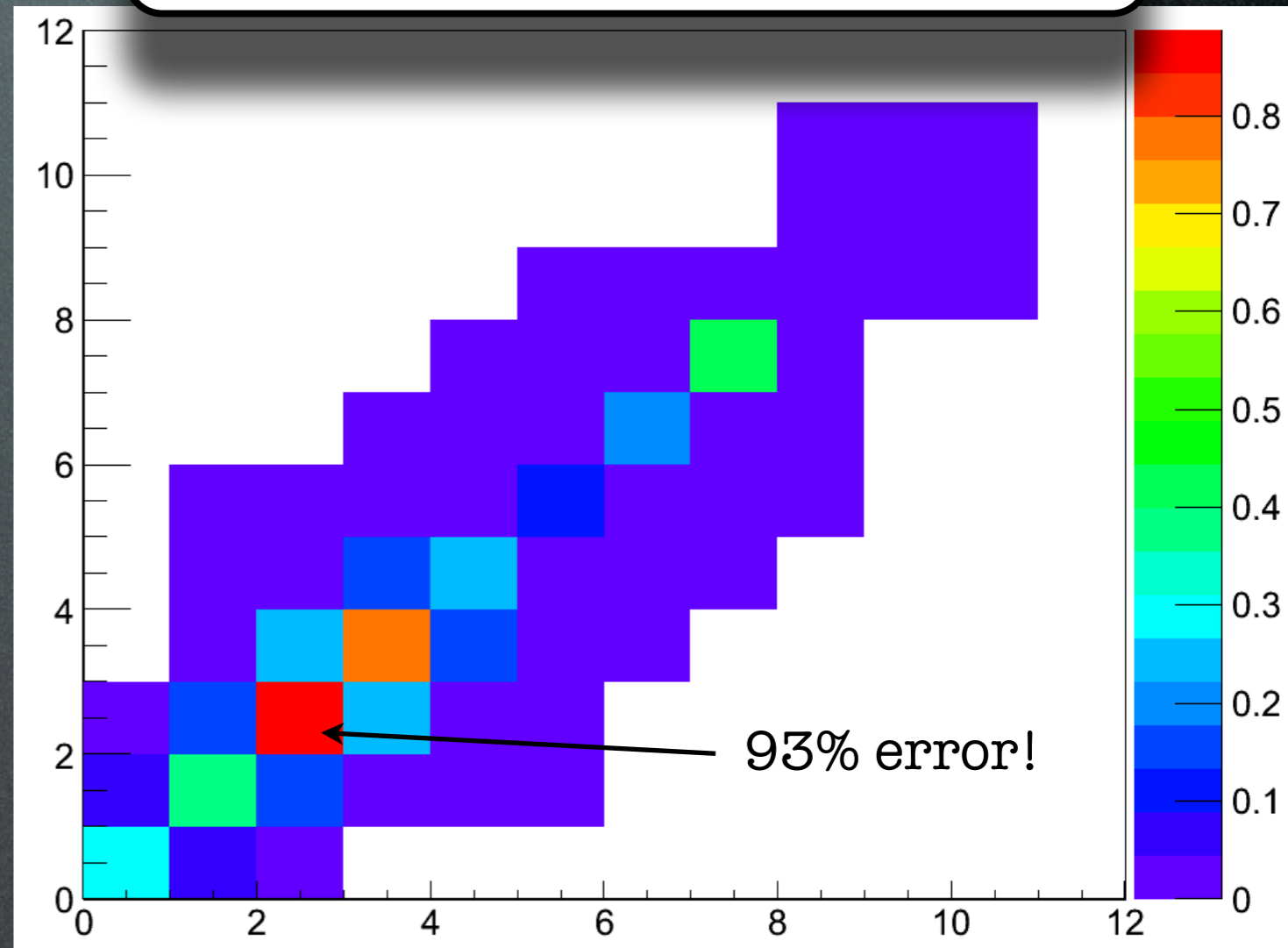

Note: with full statistics,
errors are <20%

Reducing Statistical Errors

- Flux predictions contain Monte Carlo statistical uncertainties
 - Strongly affect fit results
- Instead, can enforce that **neighboring bins must have similar weights**
 - Results in smooth variation of weights across off-axis angles
- Variance of weights is reduced by an order of magnitude
 - Significant reduction in statistical uncertainties

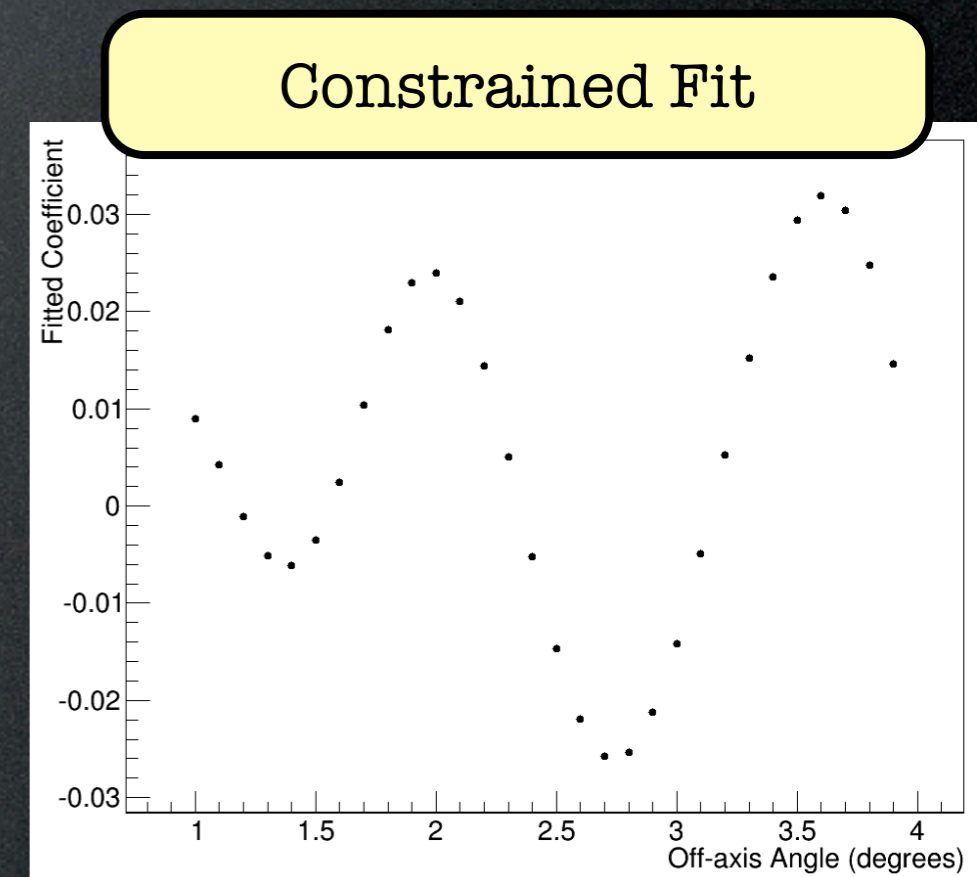
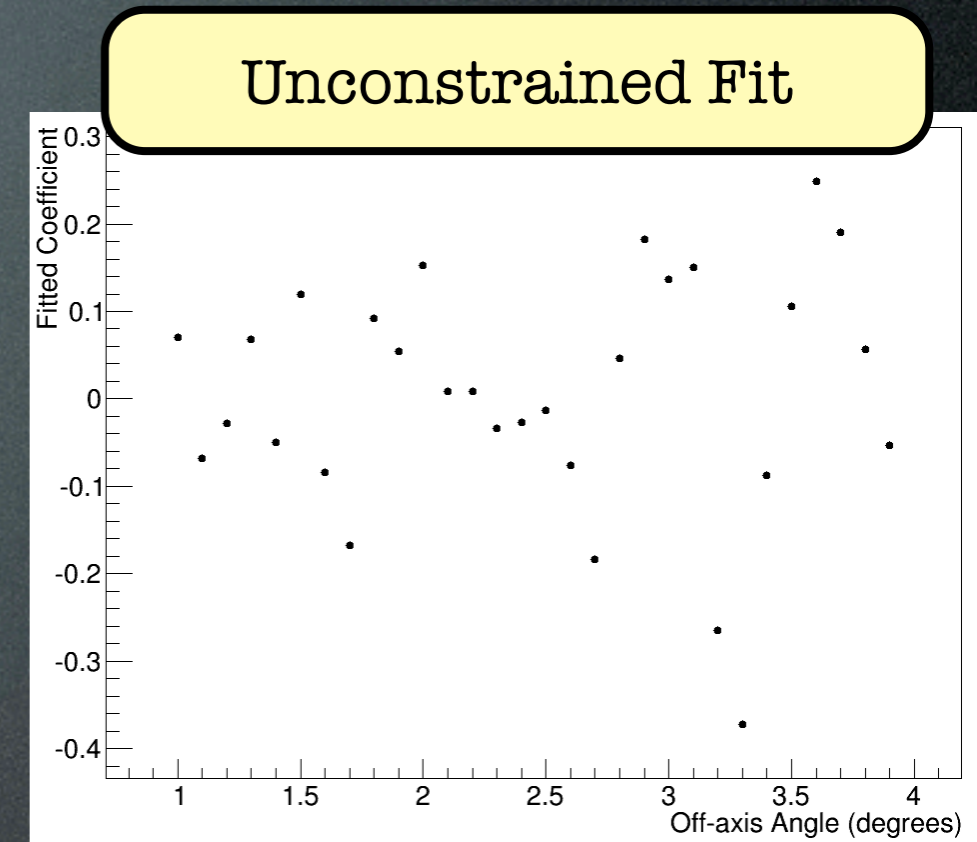

Reduced Statistical Uncertainties

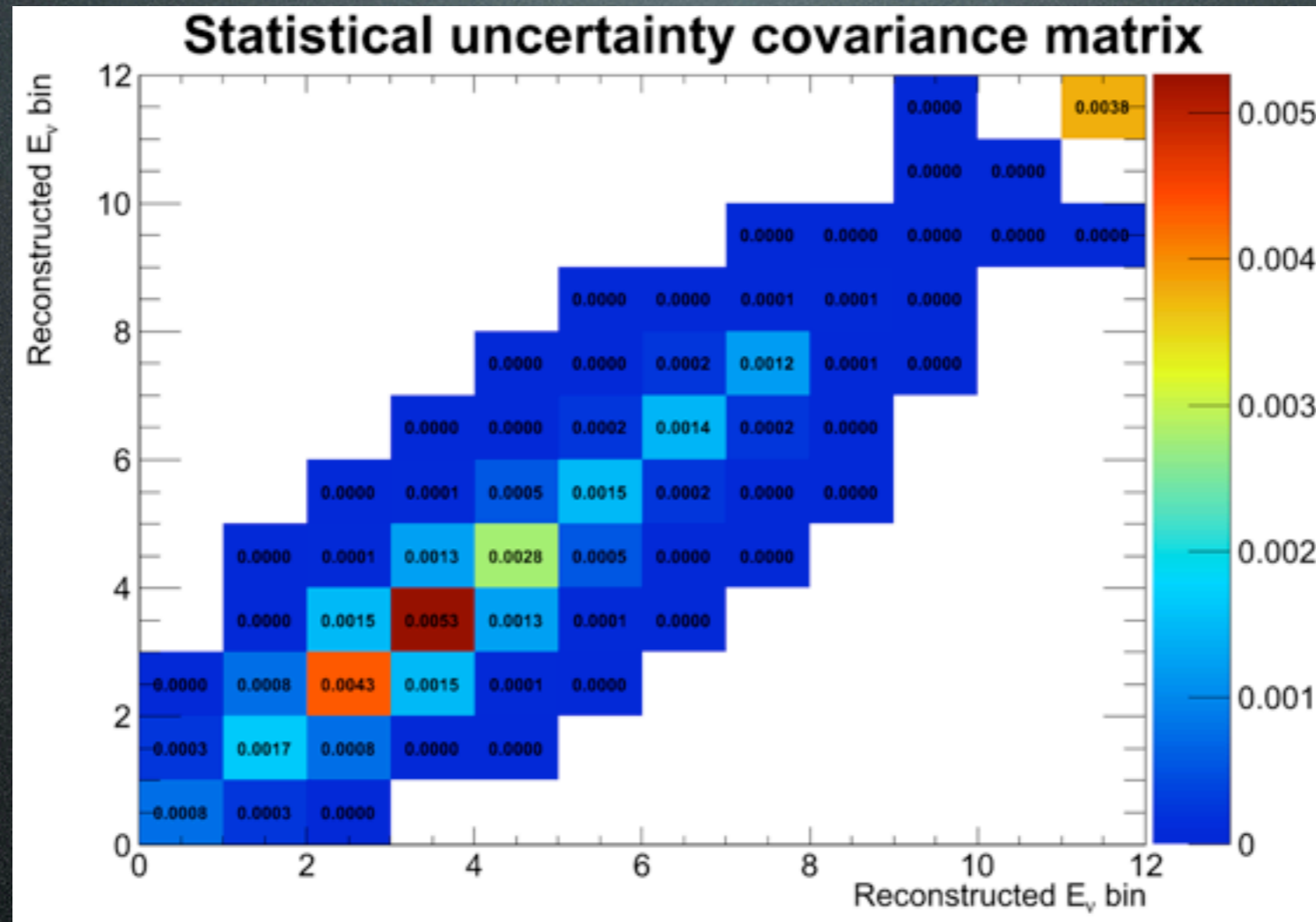

- Statistical errors have been reduced to $< 8\%$
 - Current level of systematic errors
 - Expect these to be significantly reduced with full dataset
- Statistical smoothing must be balanced with systematics associated with degraded flux fits

nuPRISM Prediction for Super-K

- **Efficiency correction** is still needed for both ν PRISM and Super-K
- ν PRISM and Super-K have **different detector geometries**
 - Particles penetrate ID wall (and get vetoed) more often in nuPRISM
 - Particle ID degrades near the tank wall
- The efficiency correction is performed in **muon momentum and angle** to be as **model independent** as possible
 - This should be nearly a pure geometry correction
- For now, fit in Super-K E_{rec} distribution (in future, just use muon p, θ)

$$E_{rec,j}^{SK}(\Delta m_{32}^2, \theta_{23}) = \sum_{p,\theta} \left[\sum_i^{OAangles} c_i(\Delta m_{32}^2, \theta_{23}) (N_{p\theta i}^{obs} - B_{p\theta i}) \frac{\epsilon_{p\theta}^{SK}}{\epsilon_{p\theta}^{\nu PRISM}} \right] * M_{p\theta j}$$

predicted
Super-K E_{rec}
distribution

weight for
off-axis slice, i

events in
muon p, θ bin
in slice, i

background
subtraction

efficiency
ratio

translation
matrix
 $p, \theta \rightarrow E_{rec}$

E_{rec} Distribution

- **For now, collapse 2D muon p, θ distribution into 1D E_{rec} plot**
 - Use CCQE formula
 - Arbitrary choice! This introduces negligible model dependence
 - Eventually, we will just use p, θ bins directly
- **Notice the ν PRISM and SK distributions disagree**
 - If they didn't, we would have no cross section systematic errors (modulo previously discussed flux variations)
 - Differences are from detector acceptance & resolution, and imperfect flux fit
- **Super-K prediction is now given by directly-measured ν PRISM spectrum!**
 - T2K measurements are now largely independent of cross section modeling!

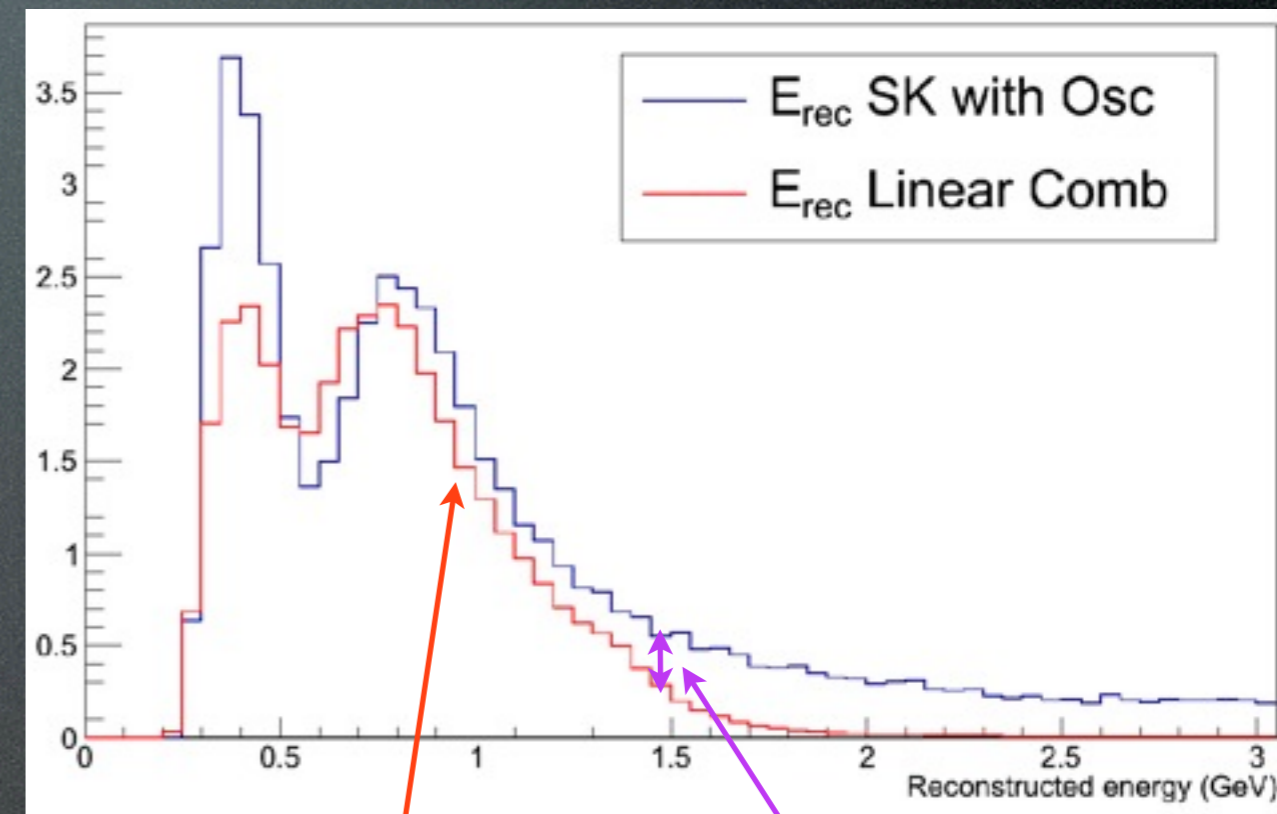

**directly
measured
component**

**model-dependent
correction factor
(systematic
uncertainty)**

Systematic Covariance Matrices

Analysis is performed in unequal-sized E_{rec} bins

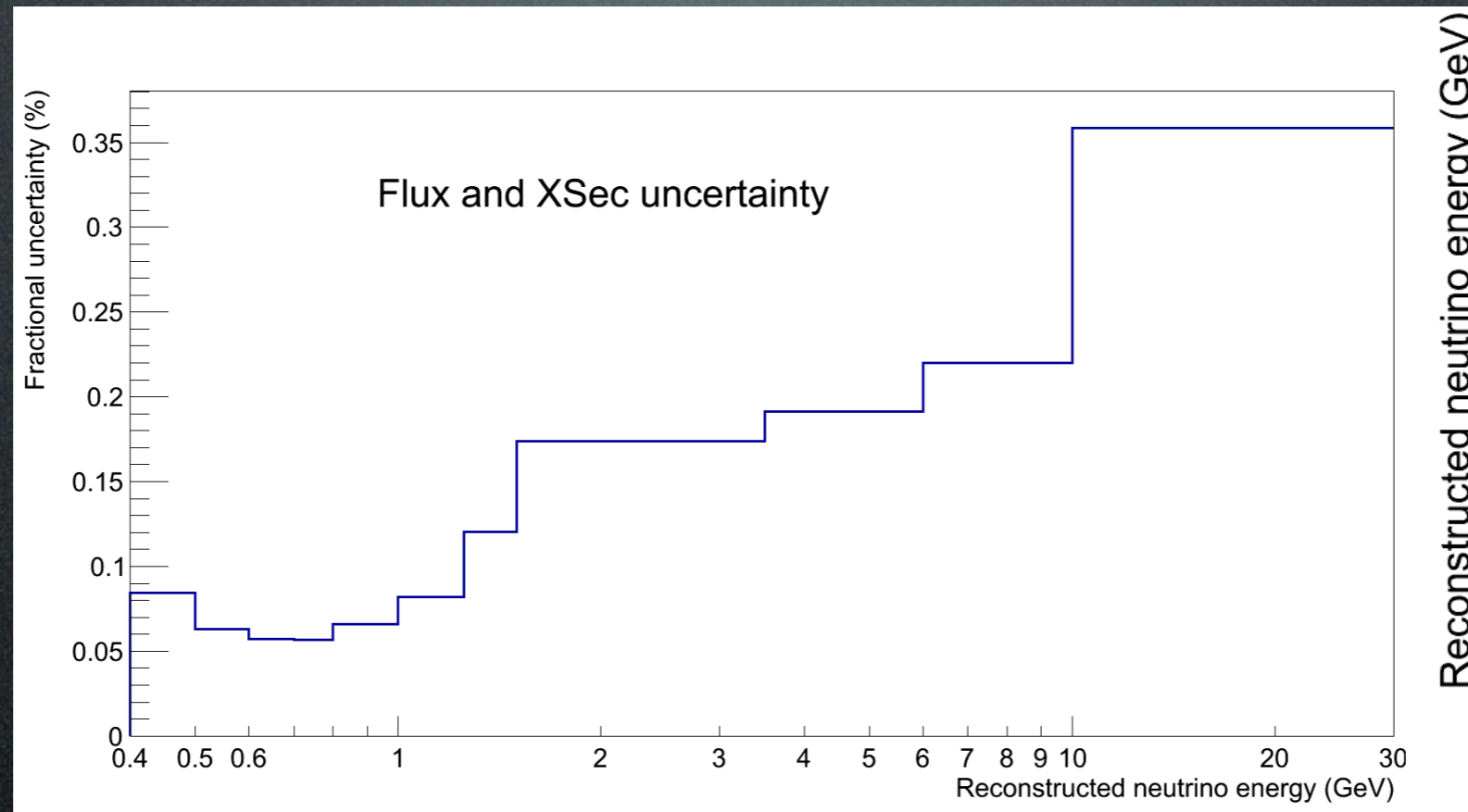

- Fractional uncertainties are shown (normalized to bin content)
- At high energies, ν PRISM provides no constraint
 - Detector acceptance: all muons exit the inner detector
 - Subject to full flux & cross section uncertainties
- Bin 3 (600-700 MeV) has a 6% uncertainty

Smoothed ν -Flux Fits

ν -Fluxes

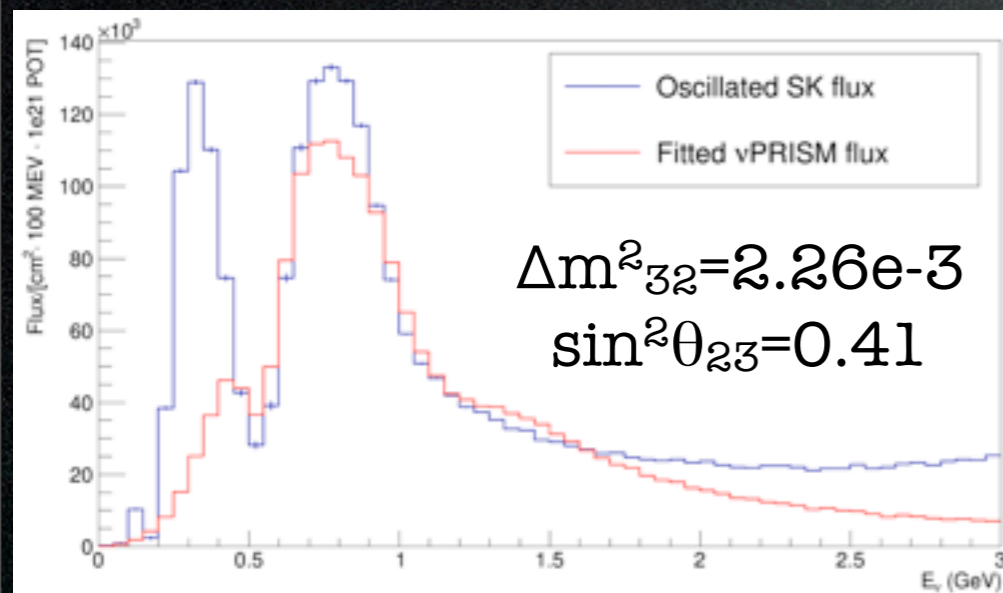
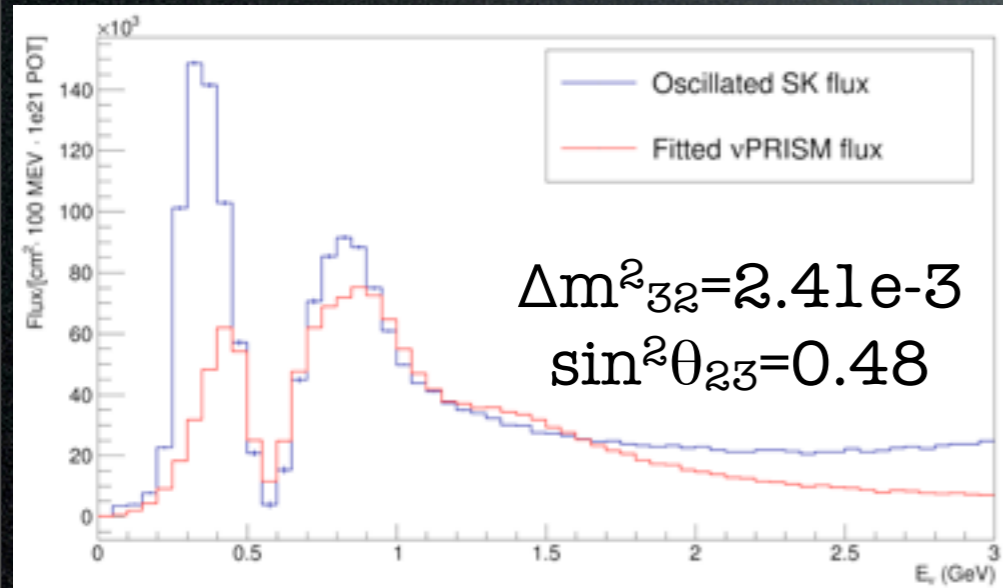
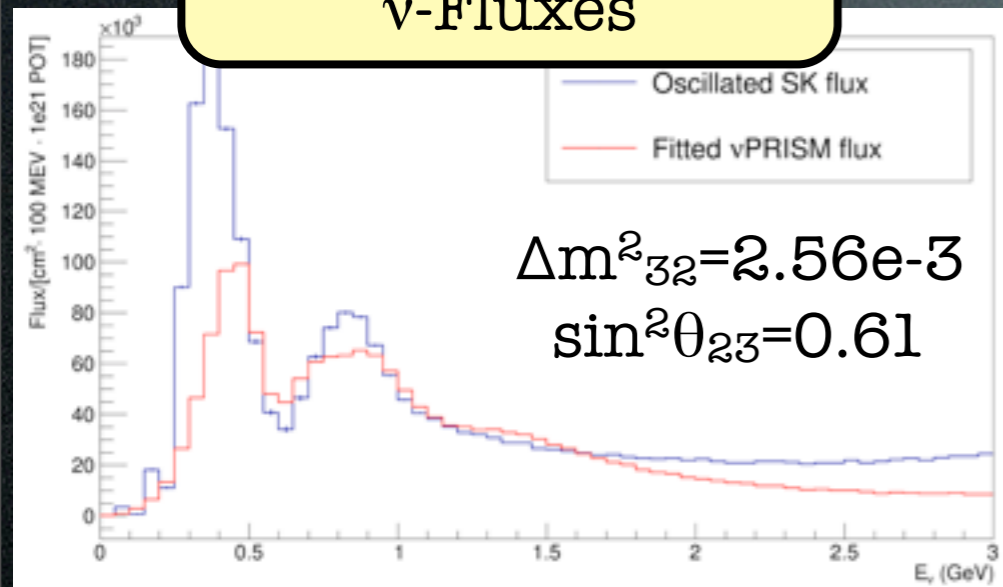

- Smoothed flux fits do not match as well
 - Easy to improve, if necessary
- However, very small increase to systematic uncertainties
 - Flux systematic variations are large
- Fits can be improved
 - Smoothness can be relaxed near fast-changing features
 - Off-axis angle bins need not be equal size

E_{rec}

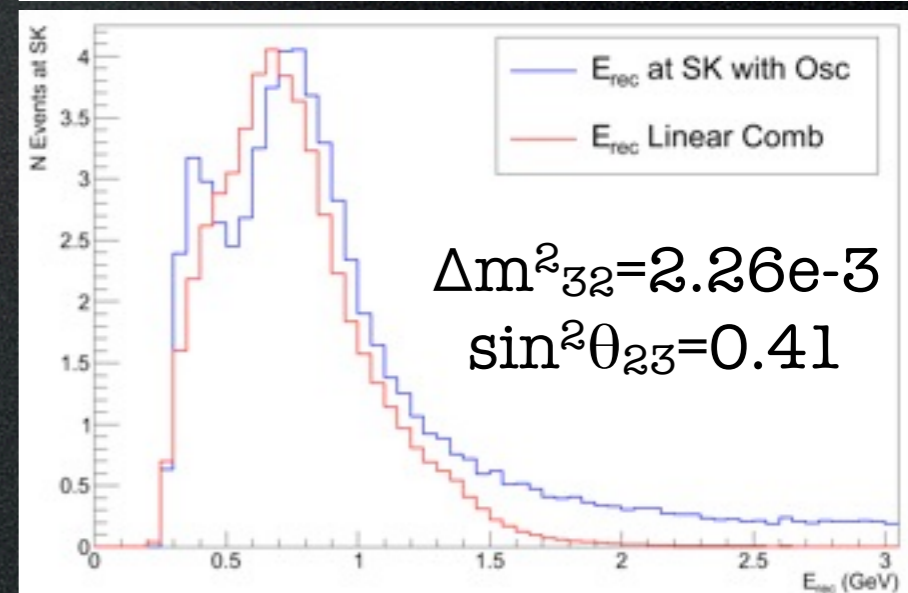
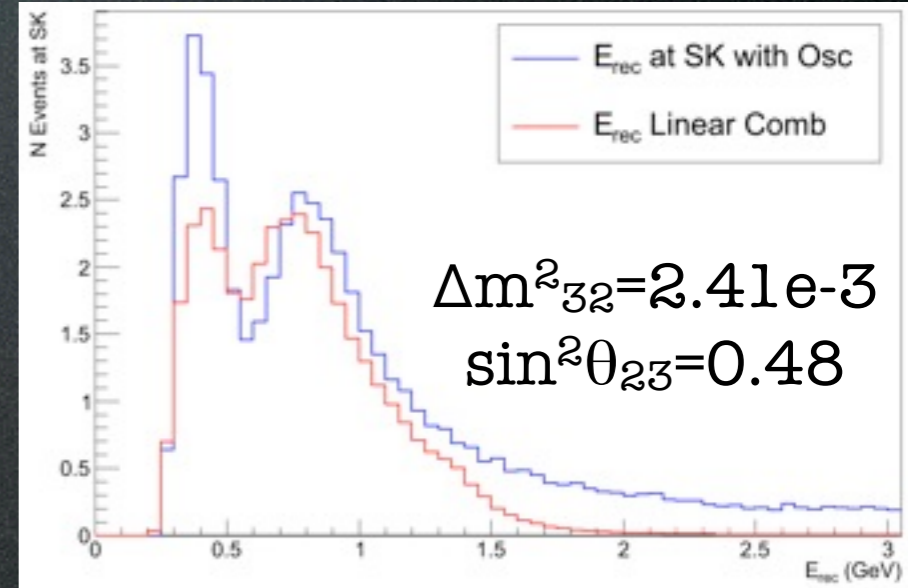
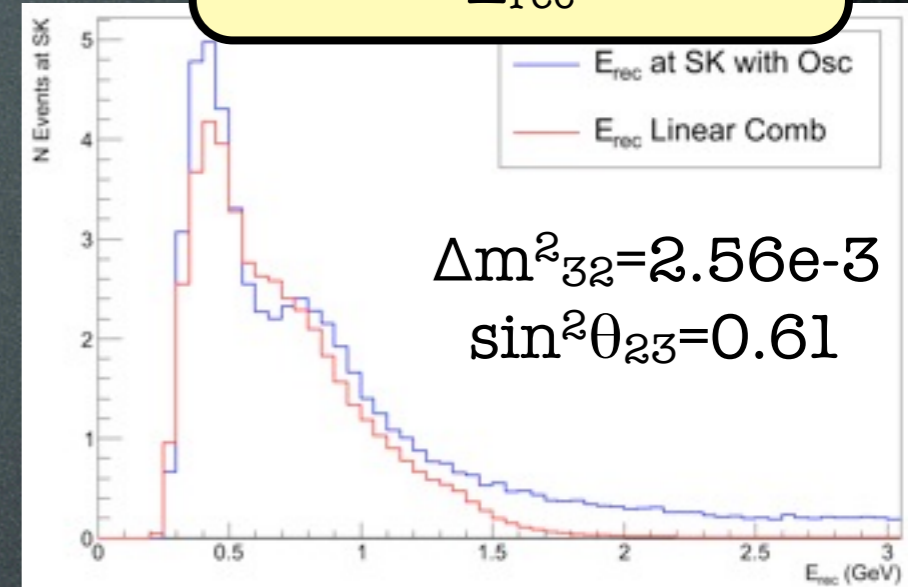

Oscillation Fits

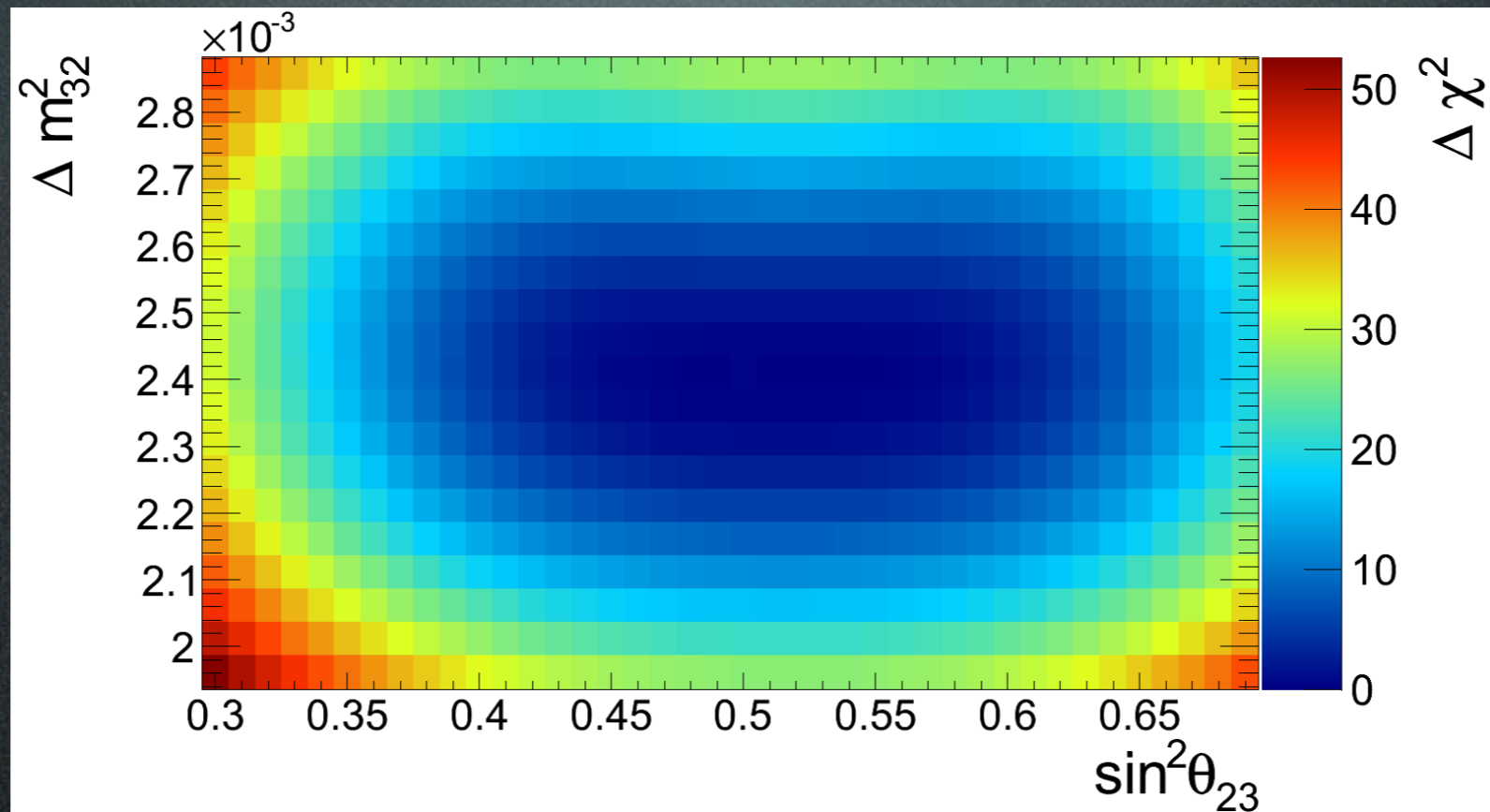

- Scan over a (coarse) grid of oscillation parameters
 - Recalculate ν PRISM spectrum and covariance matrix at each point
- Compare to Super-K distribution for a given set of oscillation parameters

ν PRISM ν_μ Disappearance Constraint

Standard T2K Analysis

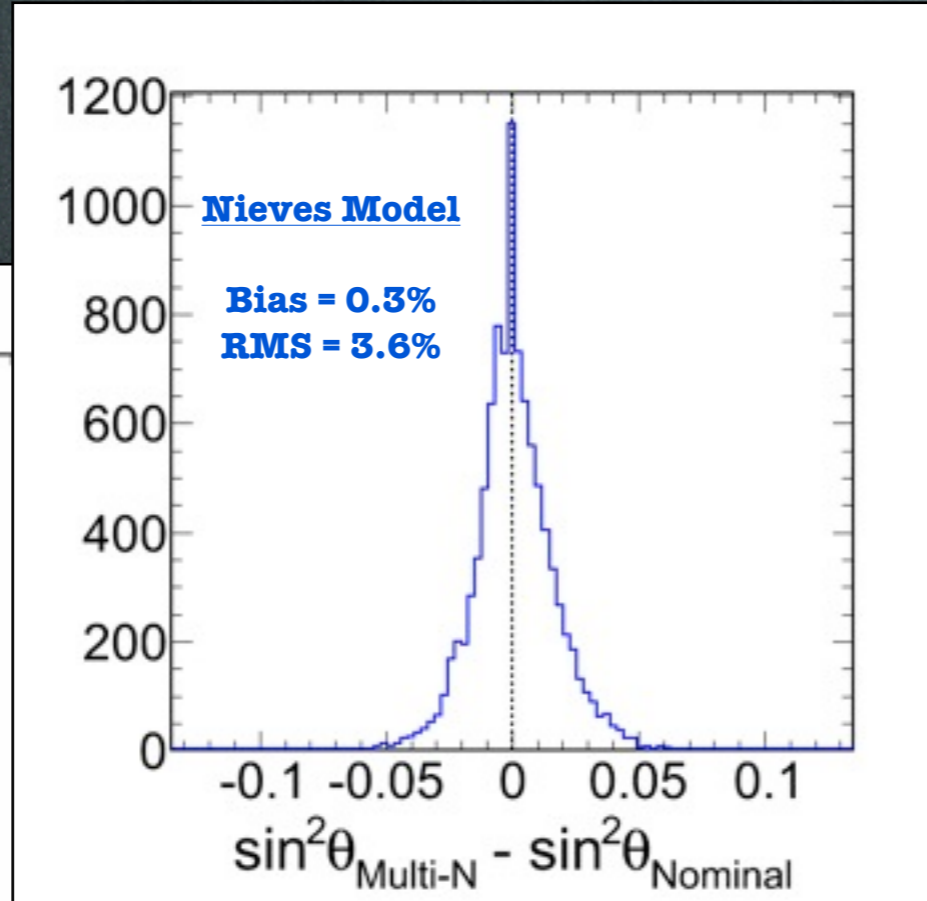
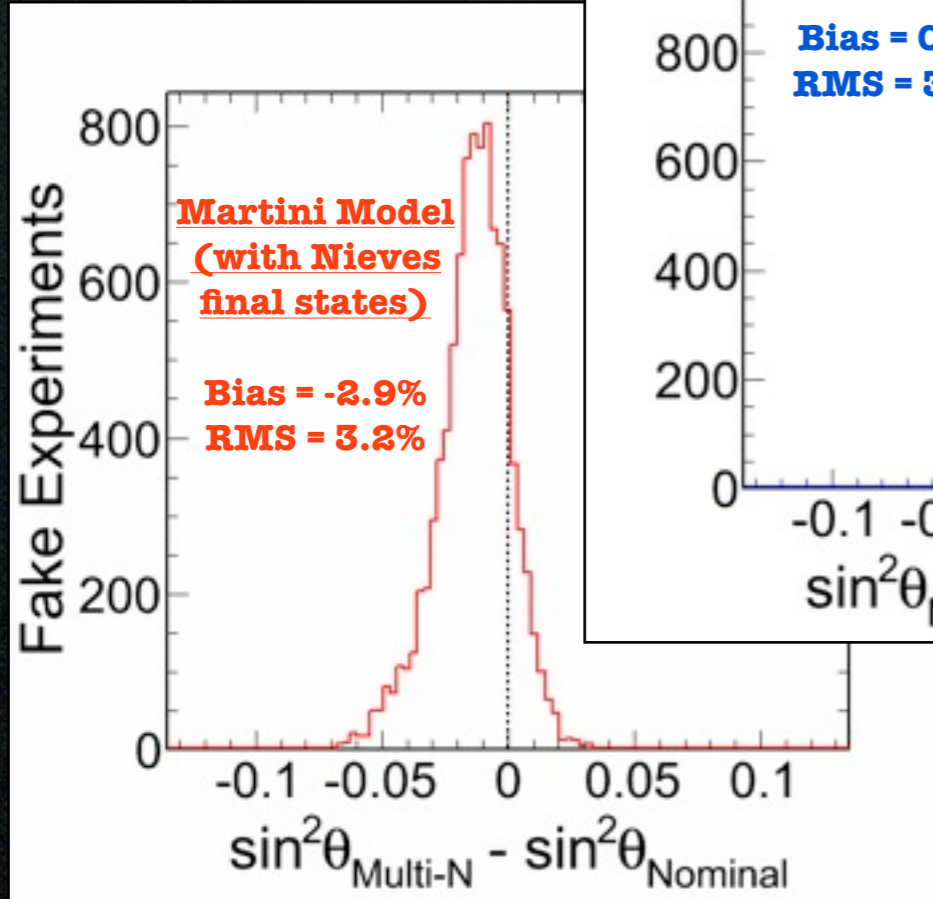

ν PRISM ν_μ Disappearance Constraint

Standard T2K Analysis

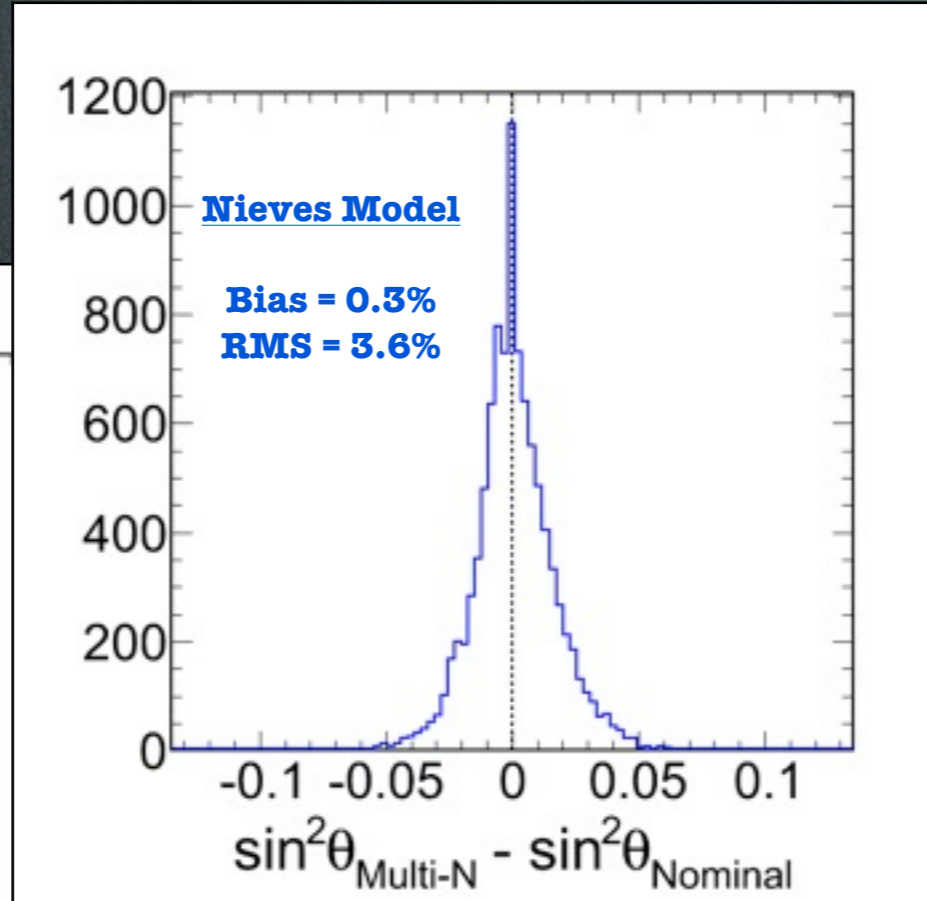
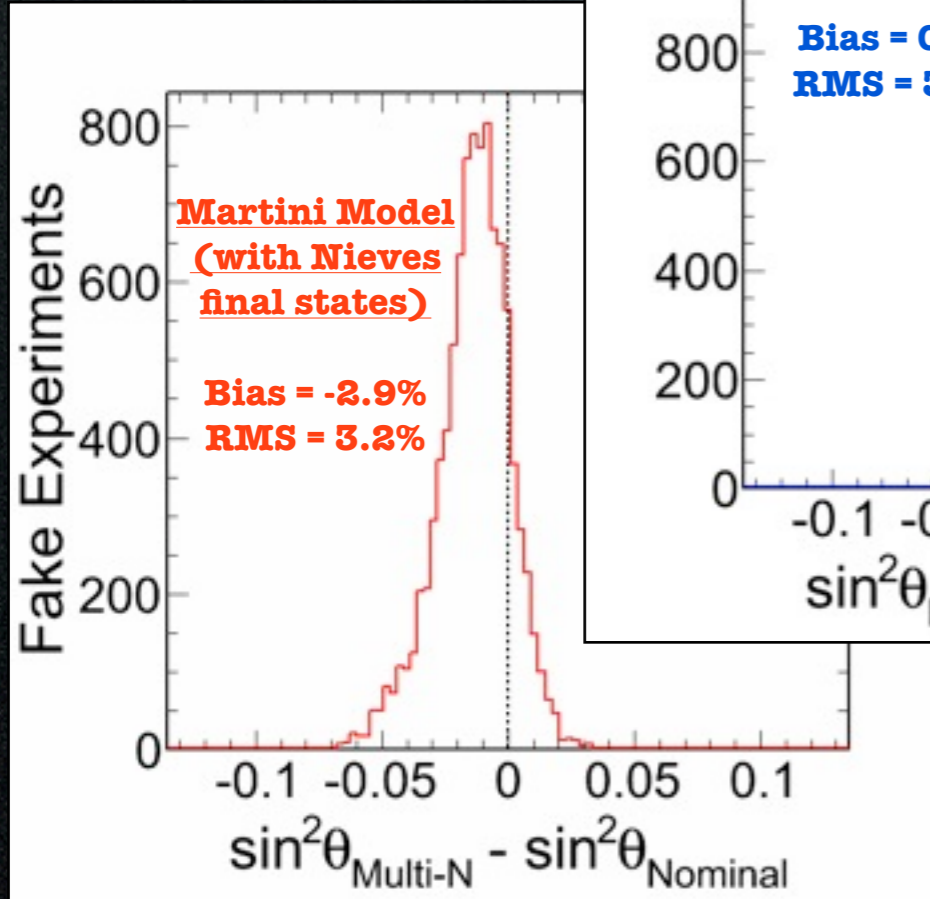

ν PRISM Analysis

ν PRISM ν_μ Disappearance Constraint

Standard T2K Analysis

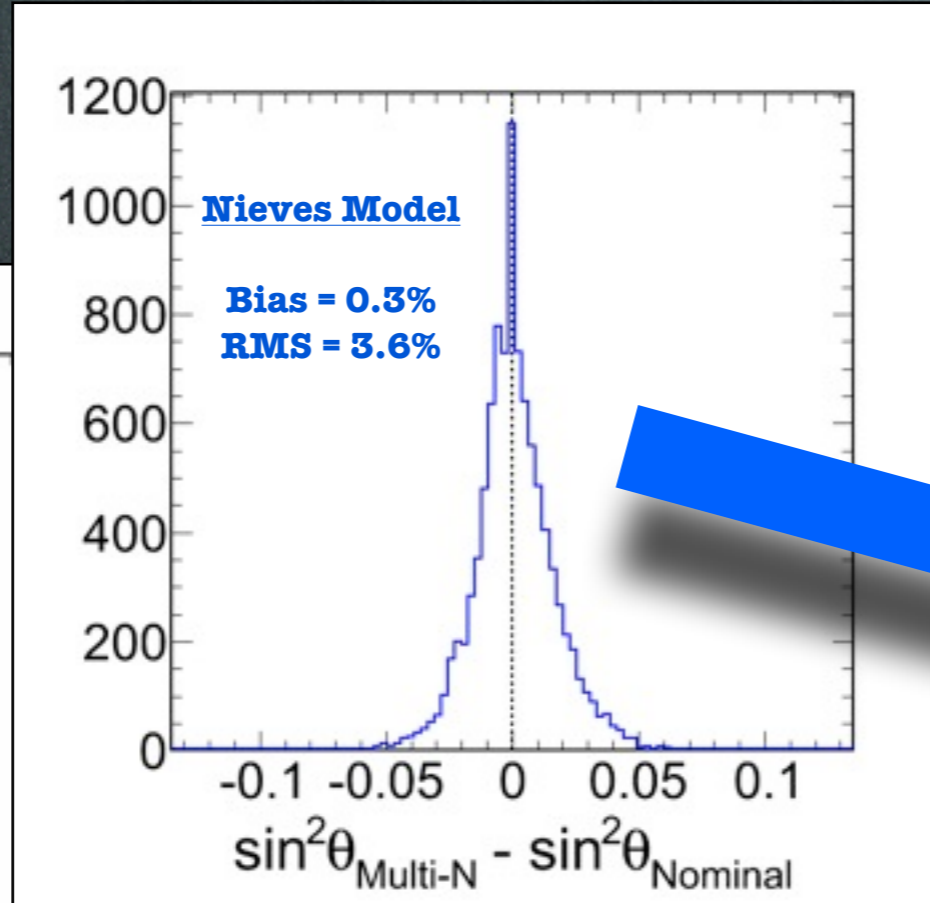
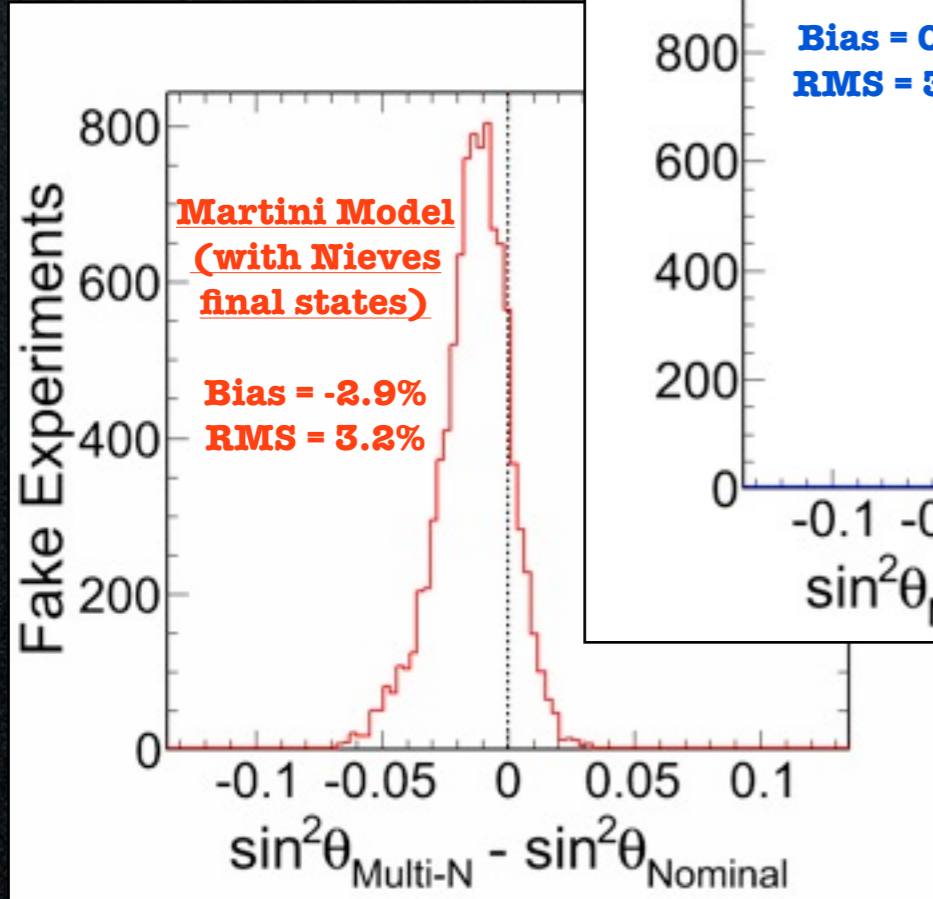

ν PRISM Analysis

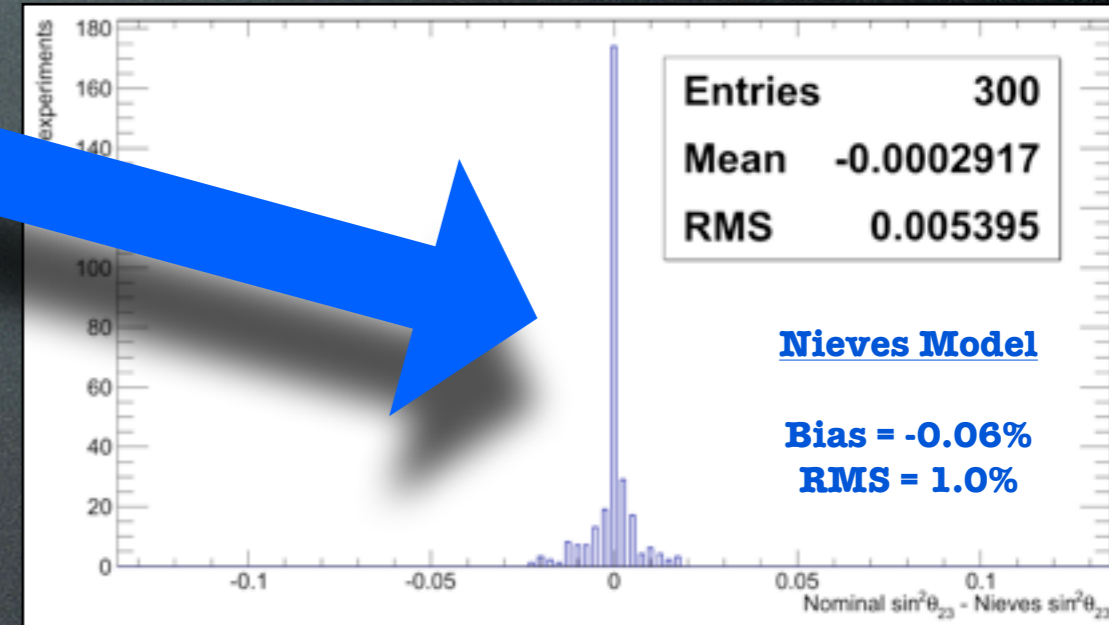

ν PRISM ν_μ Disappearance Constraint

Standard T2K Analysis

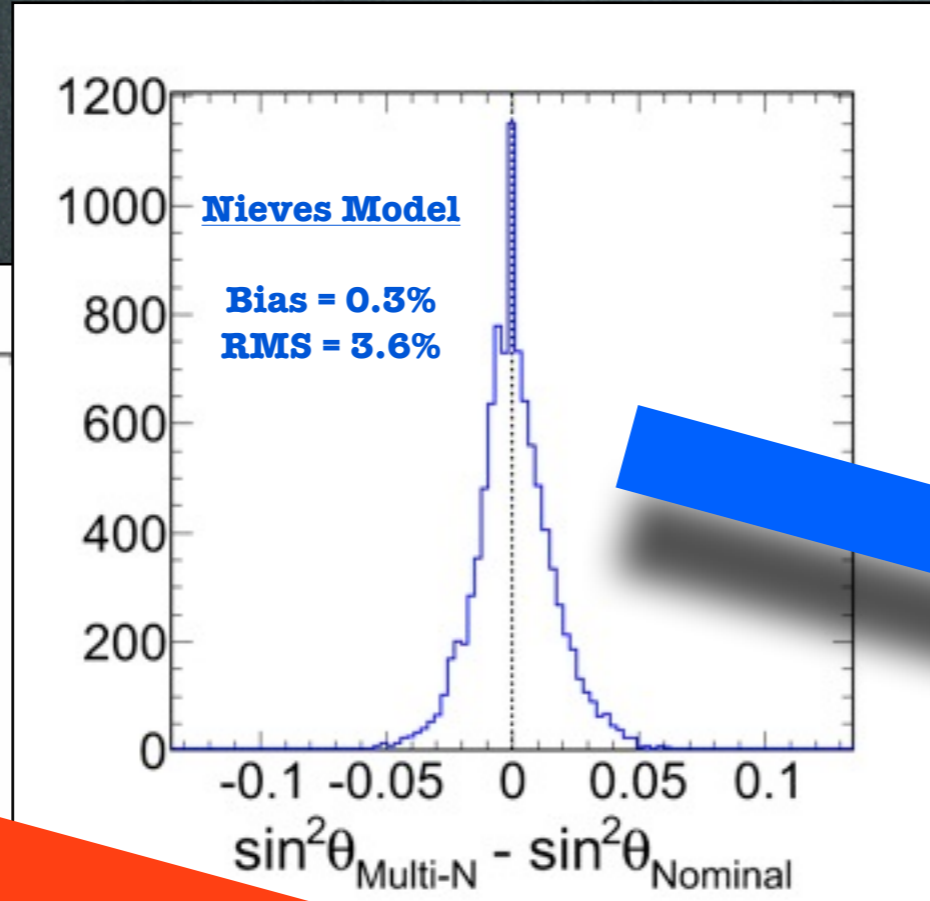
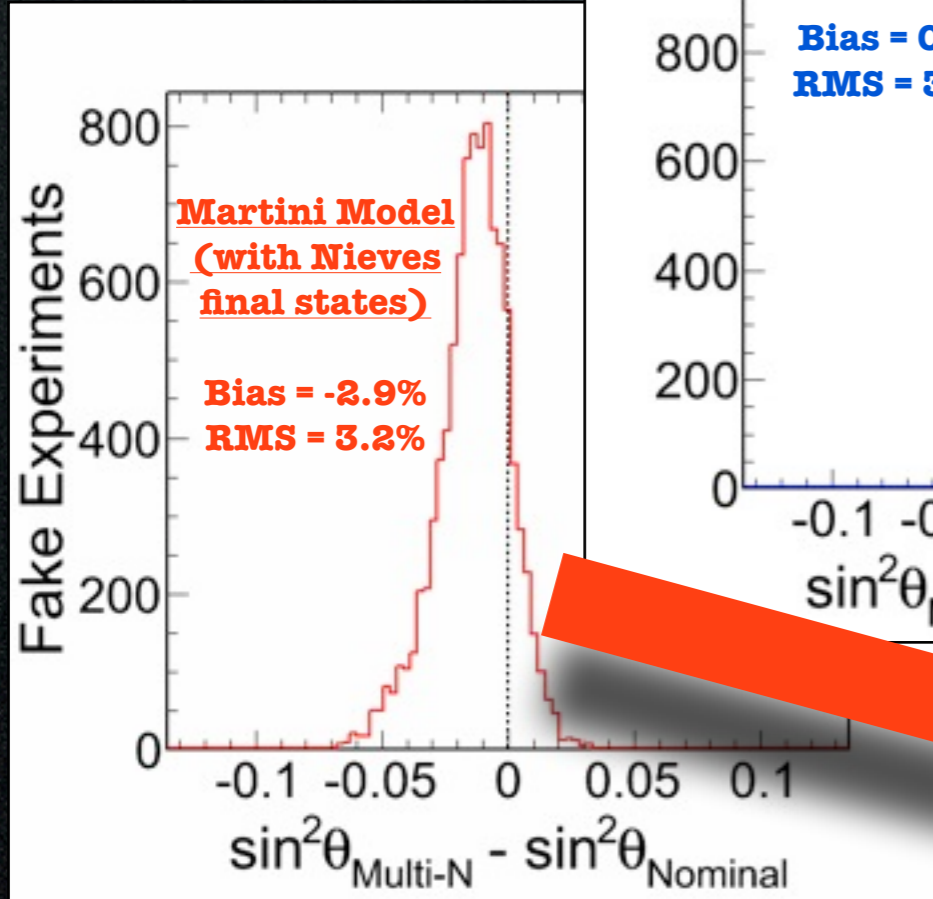

ν PRISM Analysis

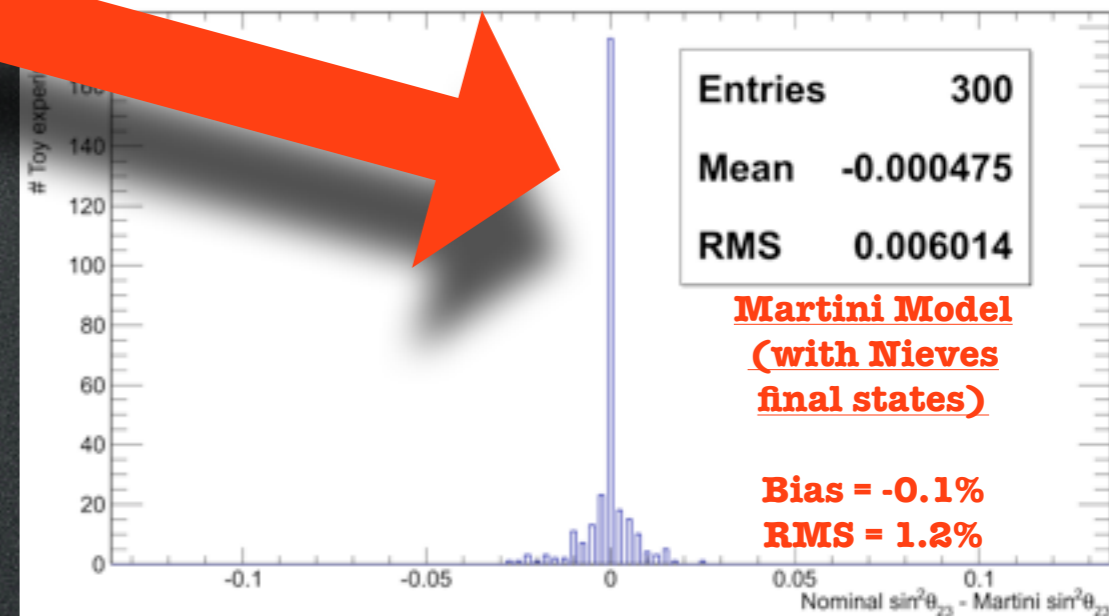
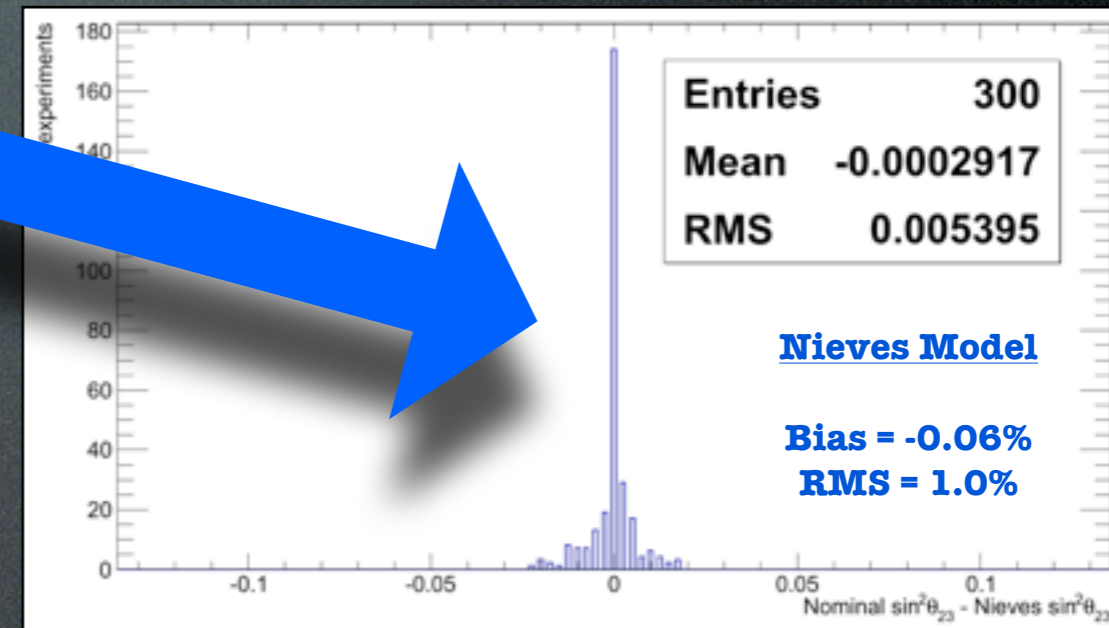

ν PRISM ν_μ Disappearance Constraint

Standard T2K Analysis

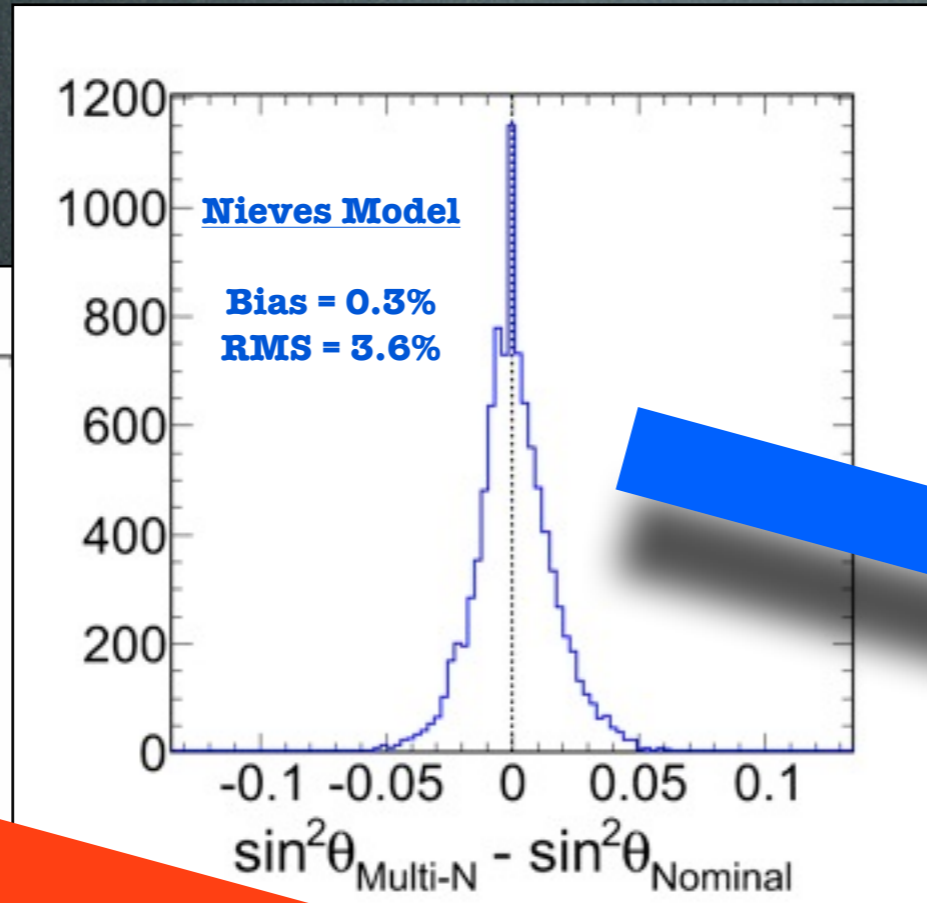
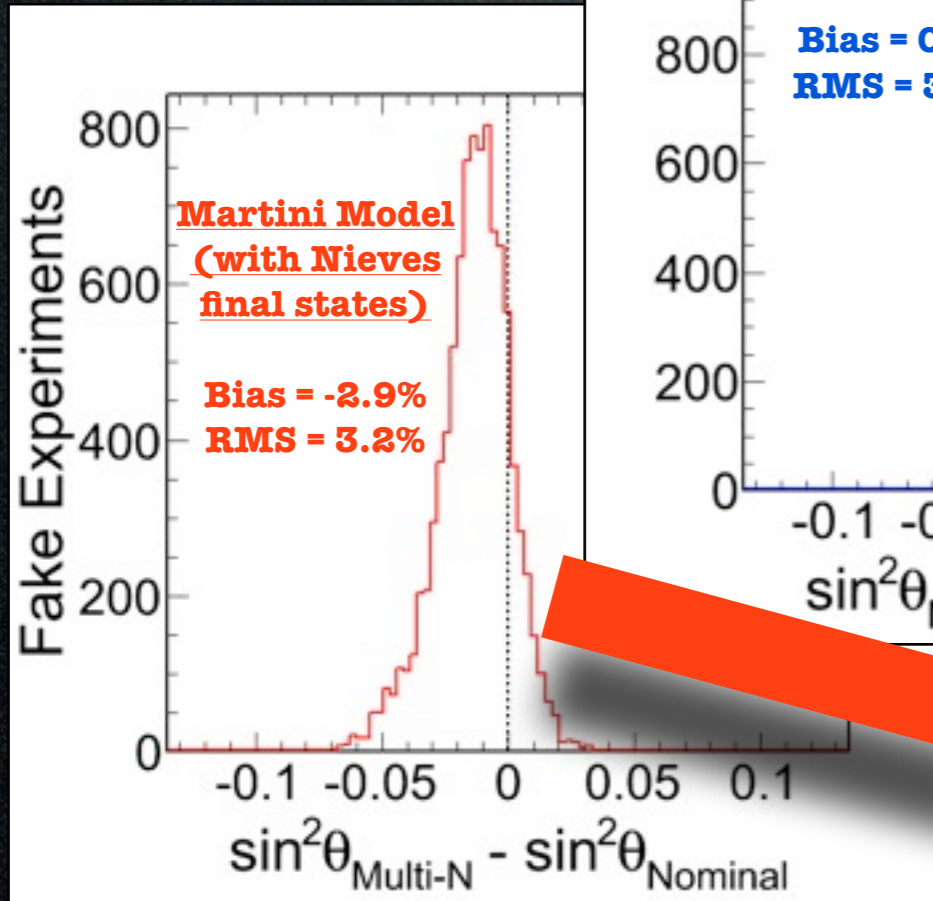

ν PRISM Analysis

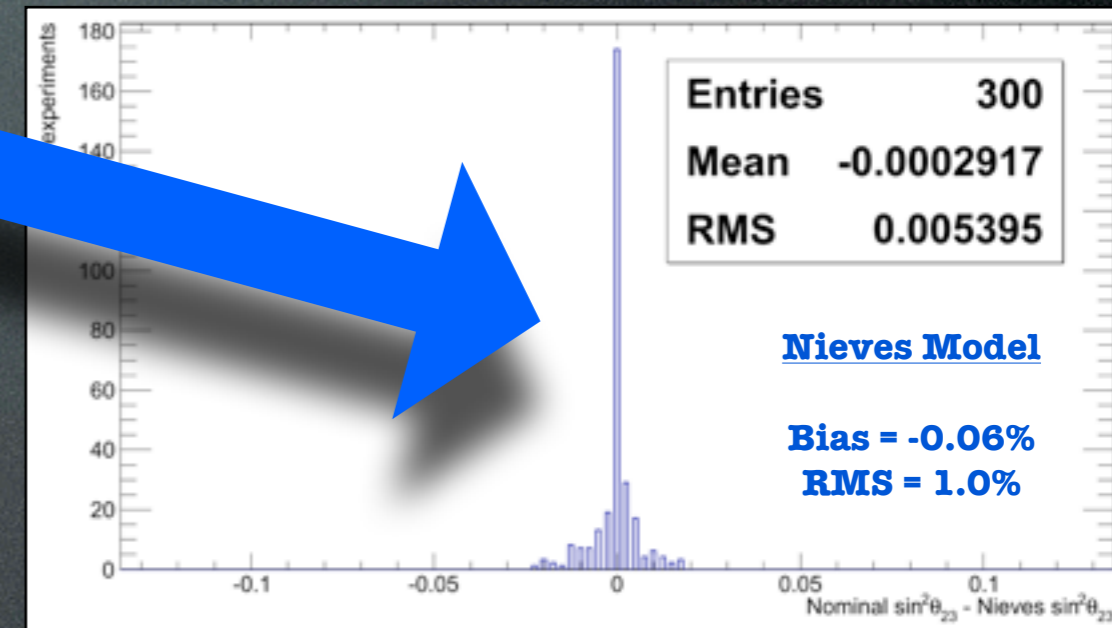

- ν PRISM analysis is largely independent of assumed cross section model
 - Using conservative systematics
 - Without using any information from the existing near detector
- Data-driven constraint works!

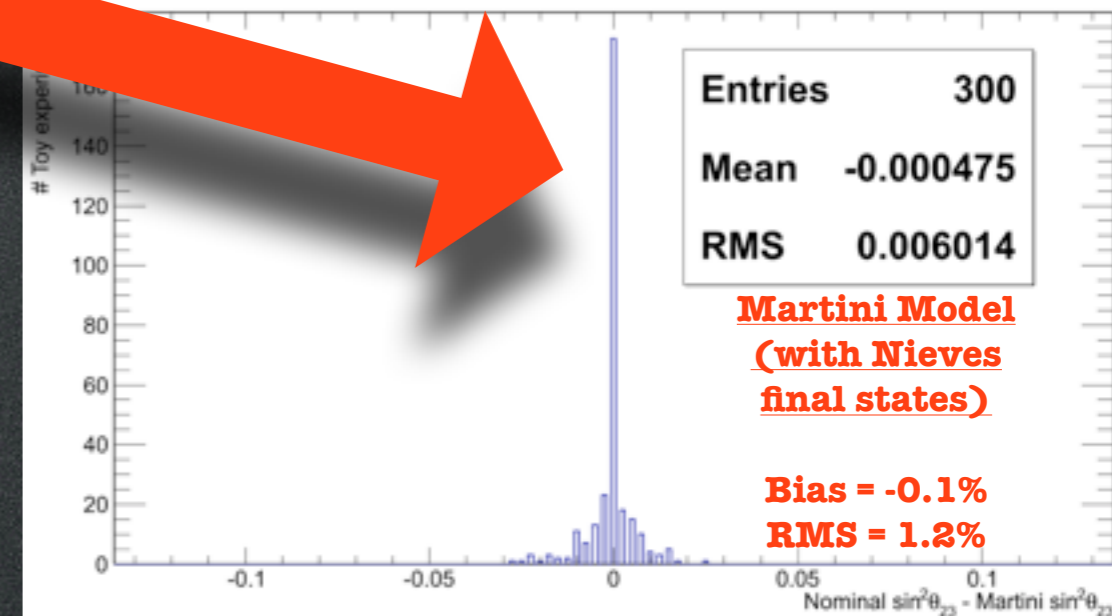

More Physics!

nuPRISM can do more than just improve
long-baseline measurements

Sterile Neutrinos

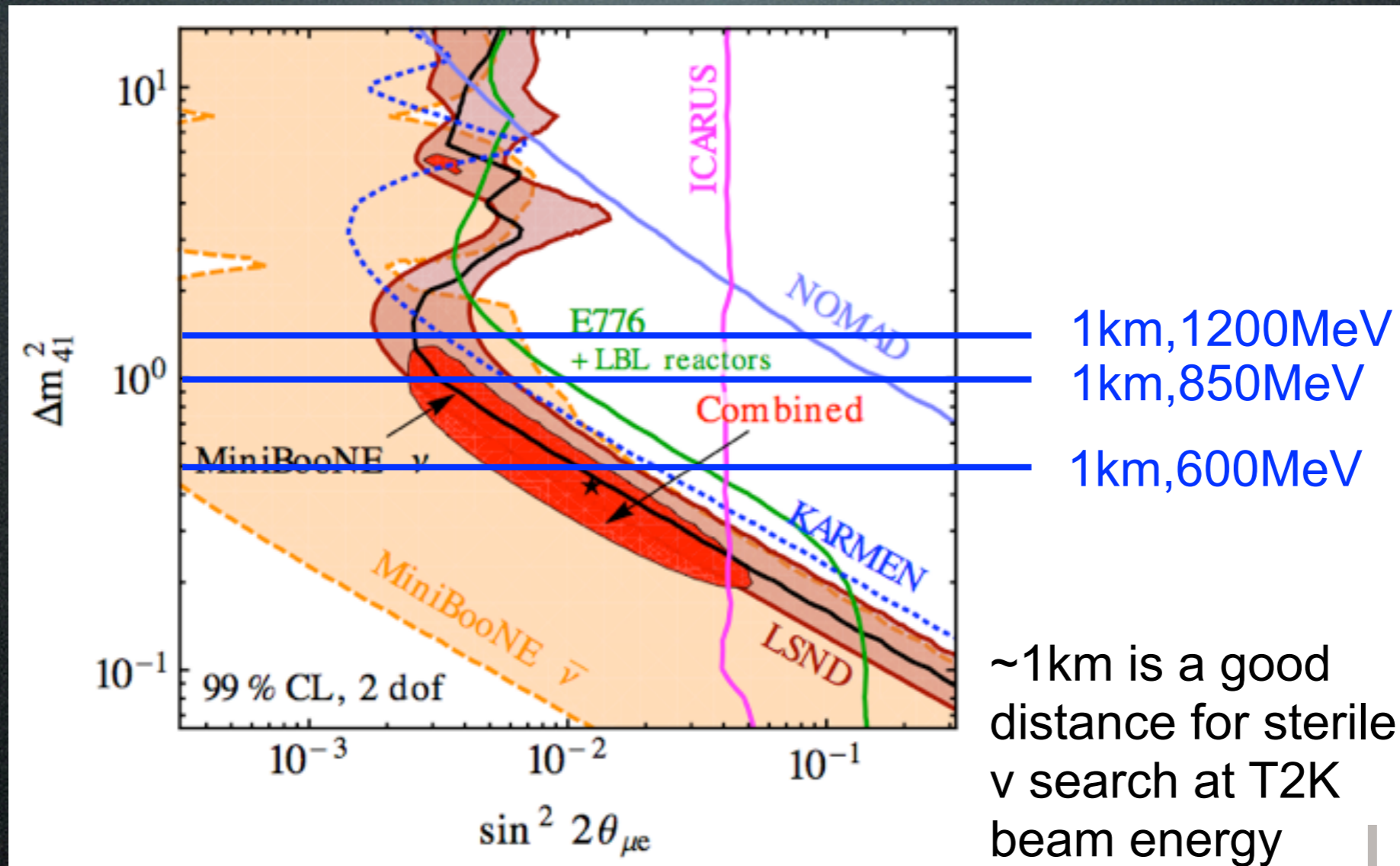

- The 1 km baseline is ideal for sterile neutrinos
 - Many repeated measurements for varying energy spectra
 - Continuously sample a variety of L/E values

Sterile Neutrino Analysis

- To compute first sensitivities, make several conservative assumptions
- **No constraint from the existing near detector (ND280)**
 - Eventually, a powerful 2-detector constraint will be incorporated
- **No constraints on background processes**
 - nuPRISM should provide control samples for all of the major backgrounds to impose strong data-driven constraints
- **No combined $\nu_\mu + \nu_e$ fit**
 - MiniBooNE results would not have been possible without normalizing the e signal to the observed ν_μ spectrum
- **Assume Super-K detector efficiencies and resolutions**
 - nuPRISM has smaller phototubes, and should perform better closer to the wall (which is important, since the diameter is much smaller)
 - Significant increase in ν_e statistics is expected
- With such conservative assumptions, is a measurement still possible?

(Very) Conservative Sterile- ν Sensitivities

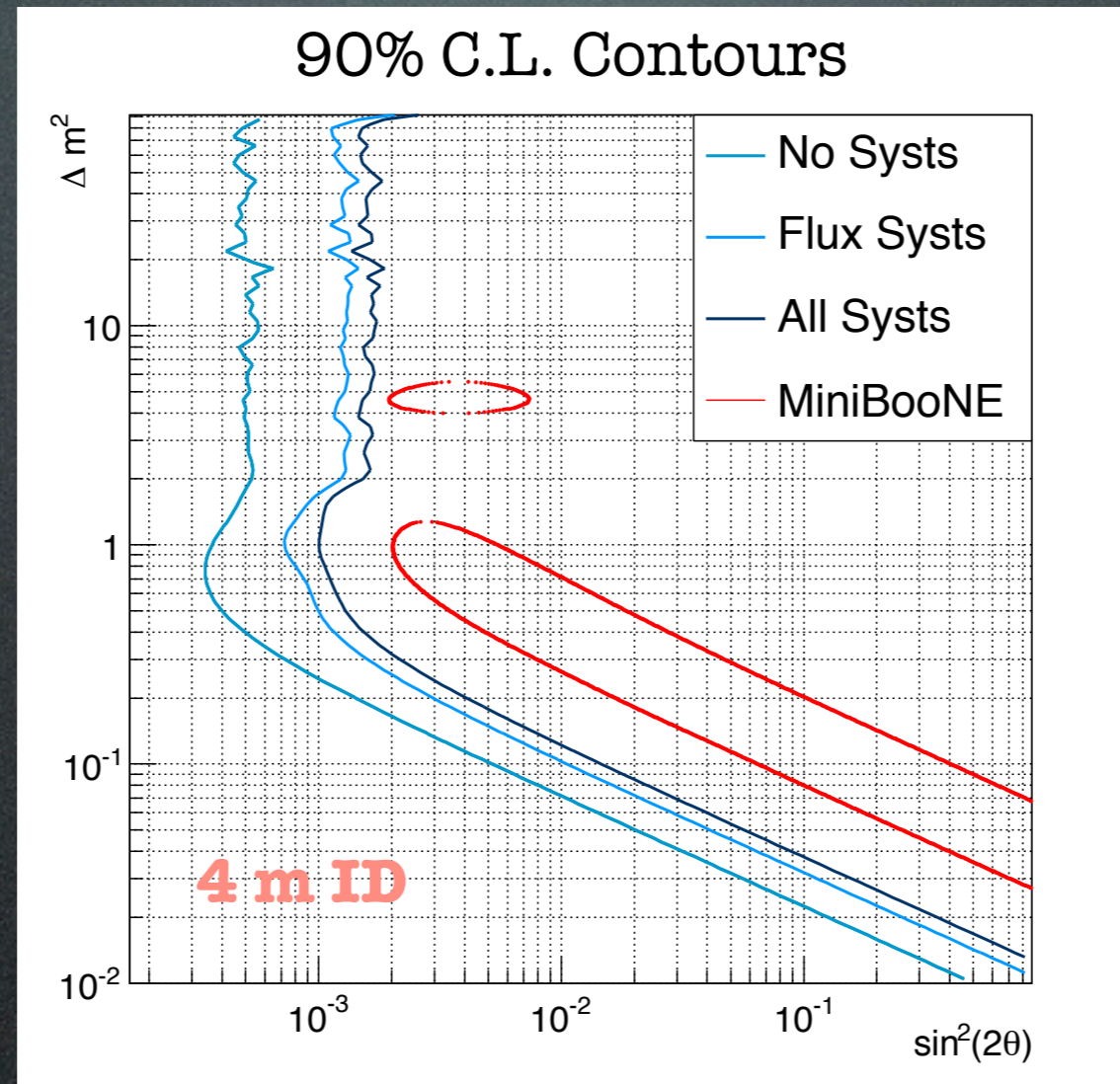

- Can already exclude currently allowed MiniBooNE regions at 90% C.L.
- Much better limits expected as the analysis improves

nuPRISM CPV (ν_e Appearance)

2 step approach:

Step 1: Measure **Super-K** ν_e response with nuPRISM ν_μ

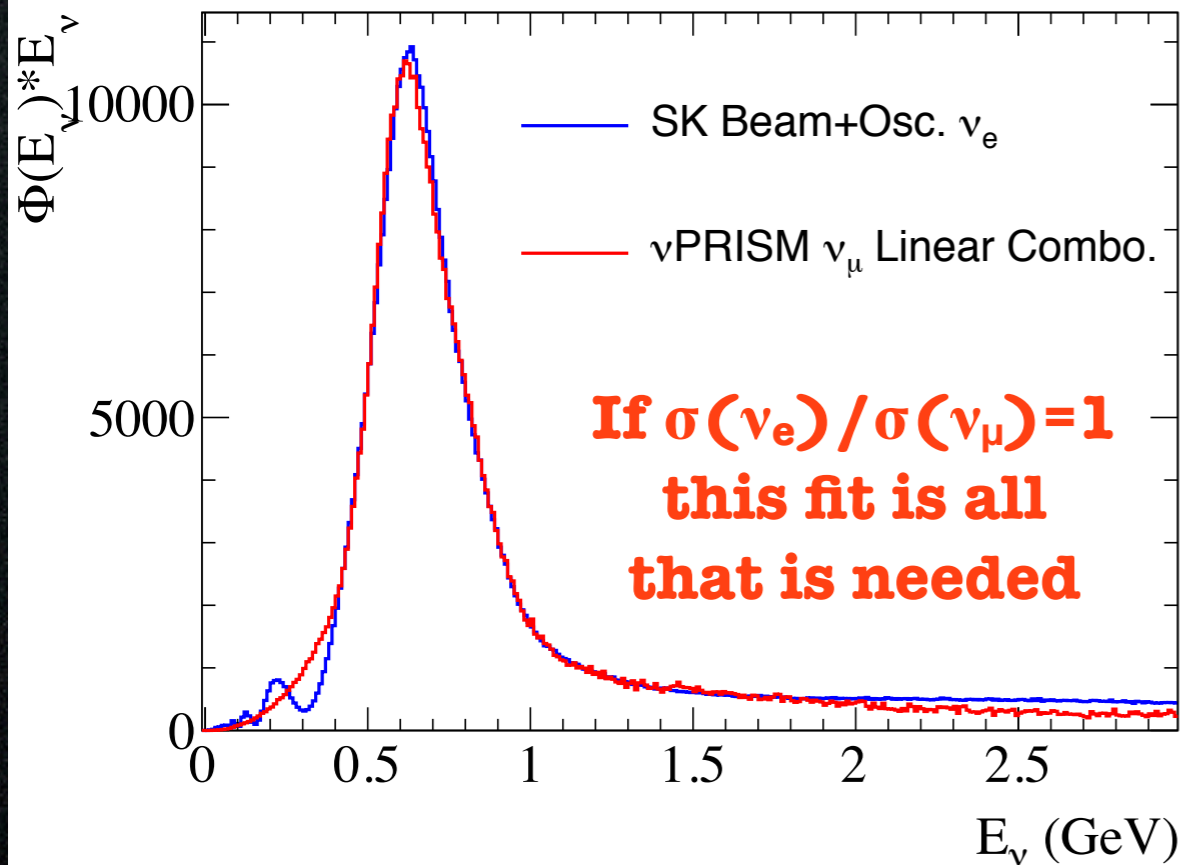

Step 2: Measure **nuPRISM** ν_e response with nuPRISM ν_μ

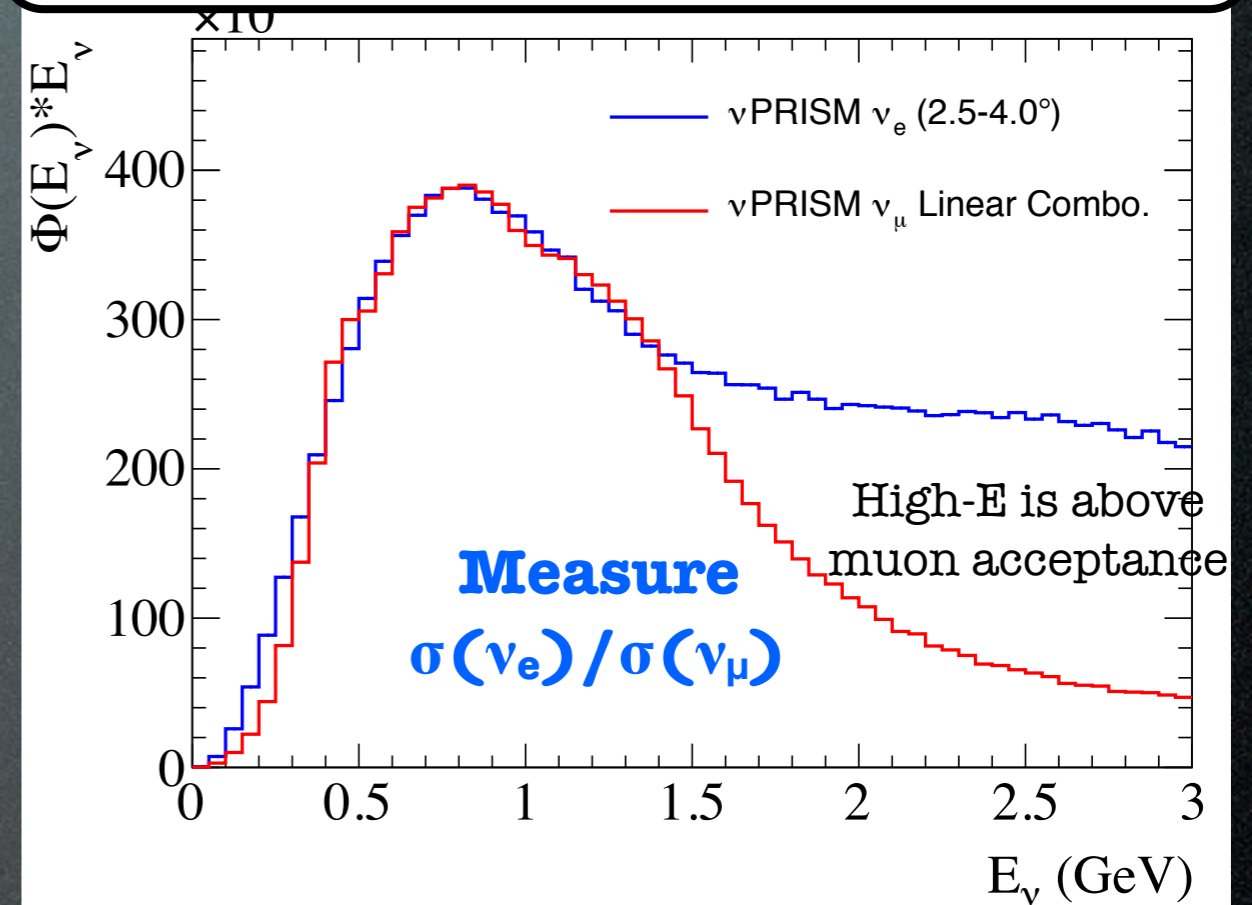

- Step 1 is the ν_e version of the ν_μ disappearance analysis
- Step 2 uses only nuPRISM to measure $\sigma(\nu_e)/\sigma(\nu_\mu)$
 - High energy disagreement is above muon acceptance
 - These plots show flux * E_ν , so difference is 1-ring μ events is smaller

Anti-neutrinos

- T2K can switch between ν -mode and anti- ν -mode running by switching the beam focusing
- Anti- ν -mode analysis is the same as for neutrinos
 - Except with a much larger neutrino contamination
- Can use ν -mode ν_μ data to construct the ν_μ background in the anti- ν -mode anti- ν_μ data
- After subtracting neutrino background, standard nuPRISM oscillation analyses can be applied to anti-neutrinos

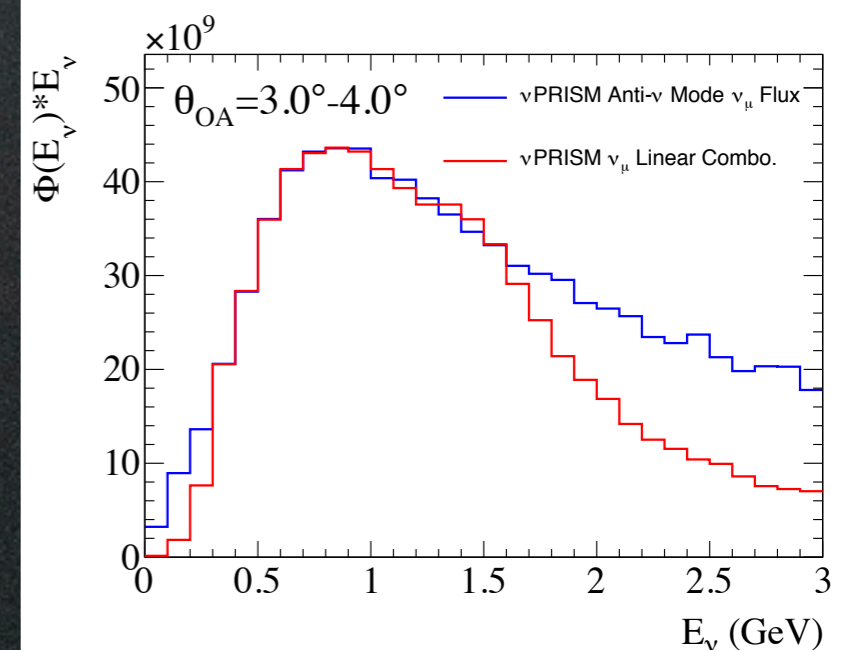
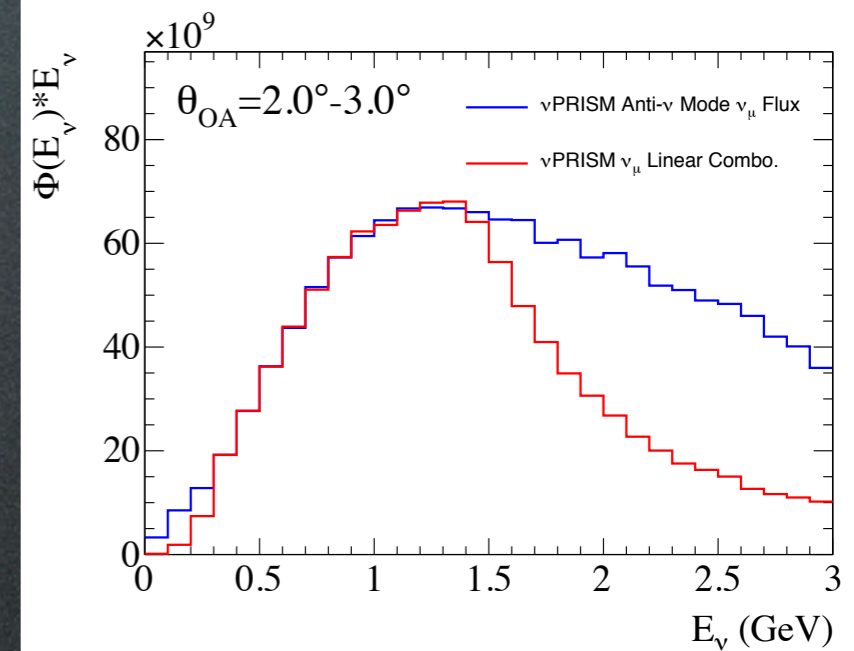
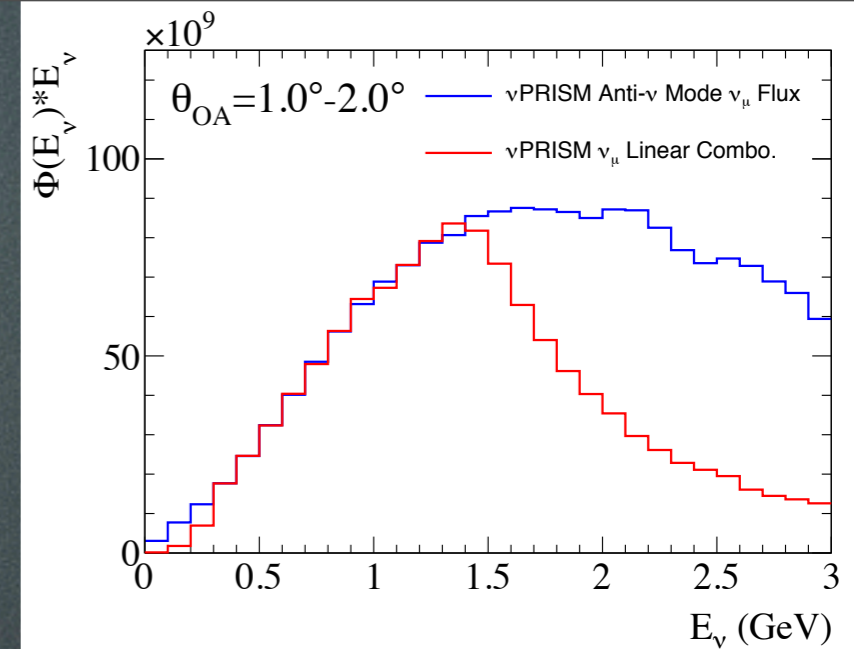

ν Cross Section Measurements

- Mono-energetic neutrino beams are ideal for measuring neutrino cross sections
 - Can provide a strong constraint on new models
- T2K ν_μ disappearance is subject to large $\text{NC}\pi^+$ uncertainties
 - 1 existing measurement
 - νPRISM can place a strong constraint on this process vs E_ν

Example MEC event separation

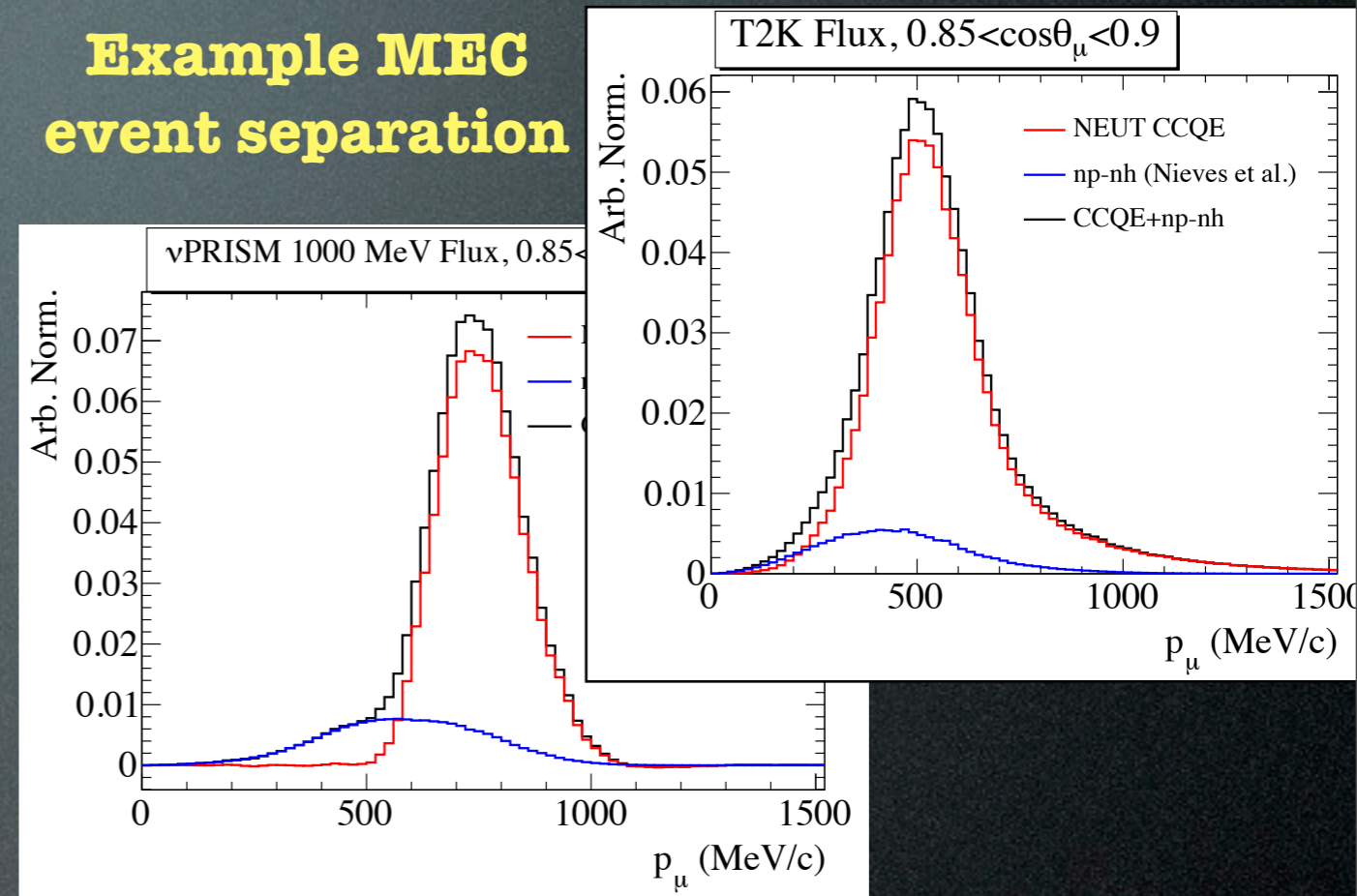

$\text{NC}\pi^+$ at T2K

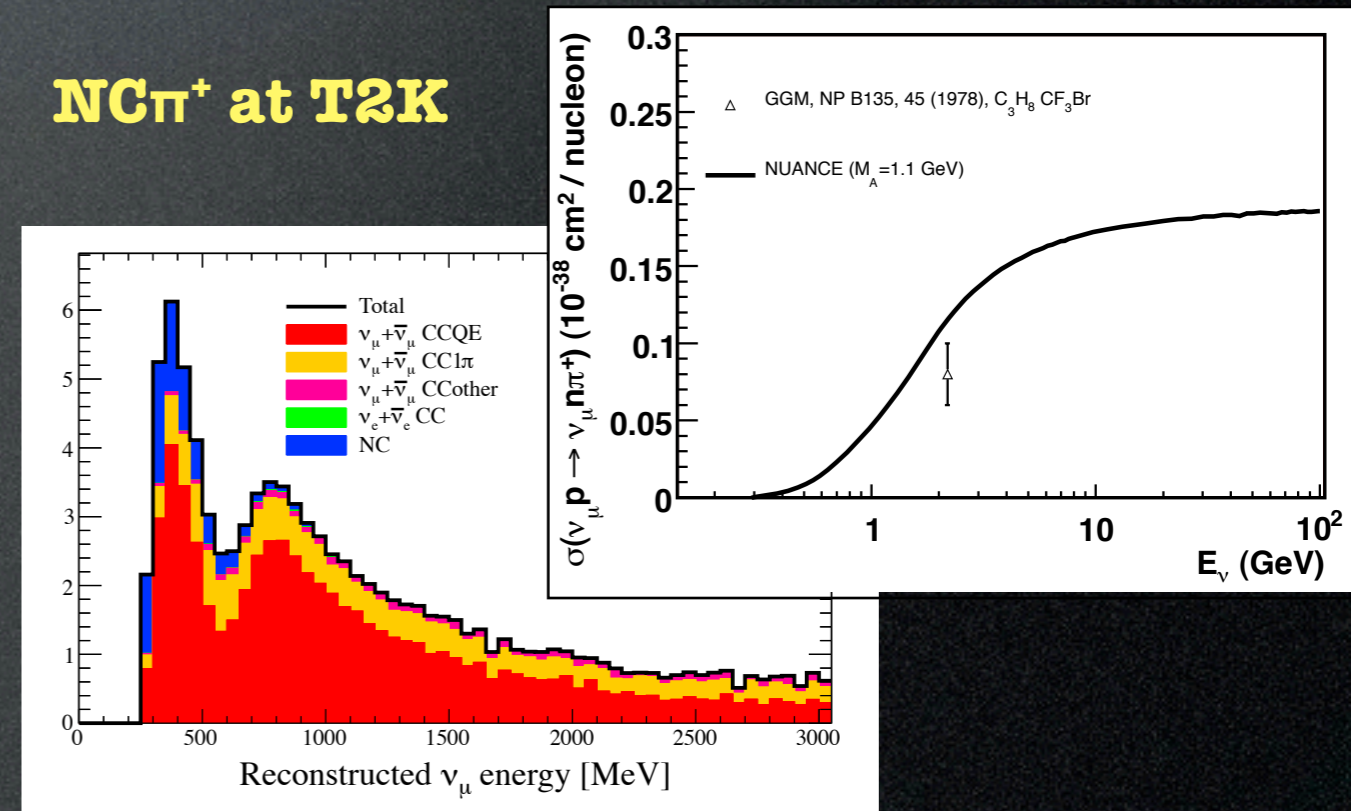

Design Considerations

Detector Location: Energy Spectrum Ratio

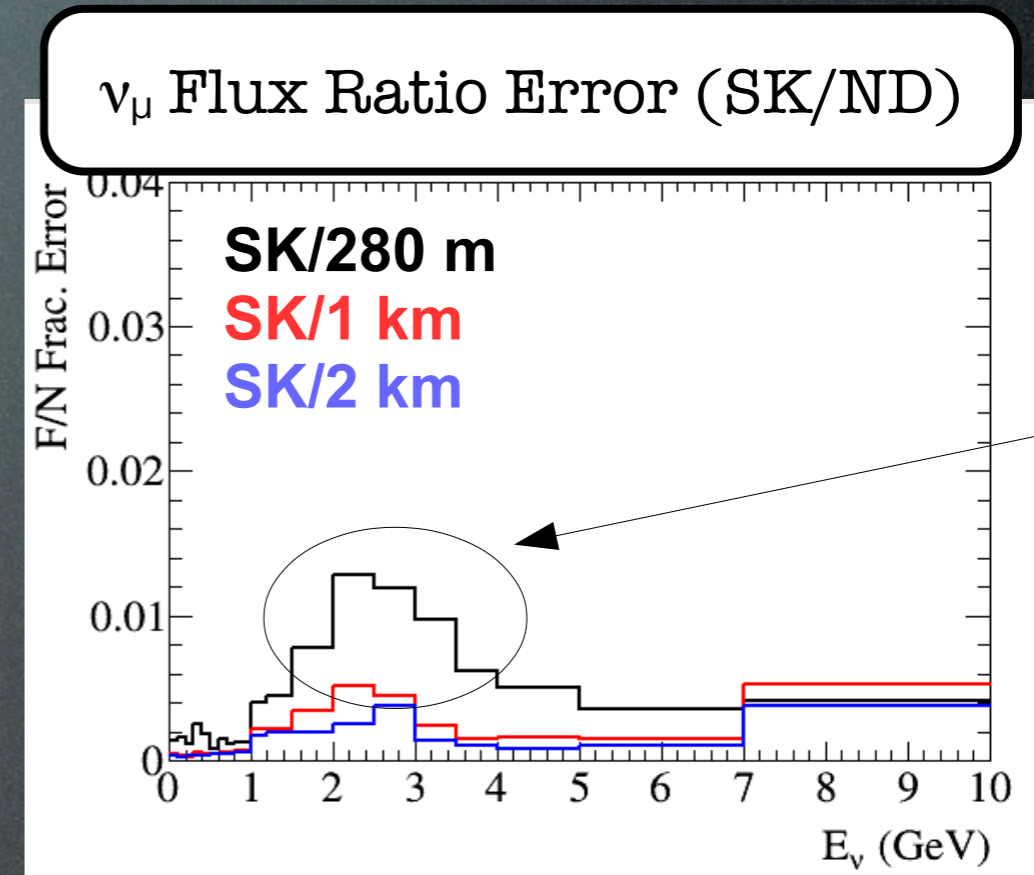
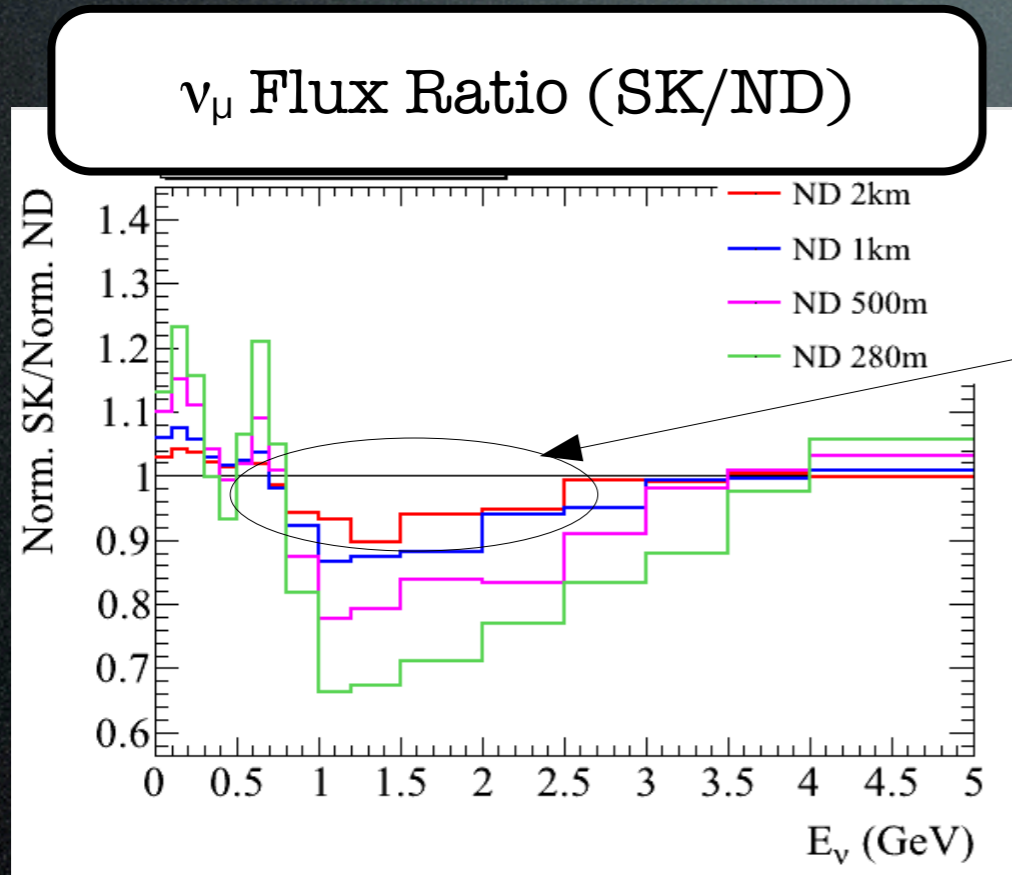

- At 280 m, the flux shape has 20-30% differences below 1 GeV
 - Uncertainty in the ratio is noticeably larger, but mostly above 1 GeV
- The difference between 1km and 2km is small in both shape and shape uncertainty

Other Design Considerations

- **Civil construction is expensive!**
 - Smaller hole = More affordable
- **Off-axis angle range (i.e. E_ν range)**
 - On-axis flux peaks at 1.2 GeV
 - 4° (6°) off-axis peaks at ~ 380 (~ 260) MeV
 - Beam points 3.63° below horizon, so get $\sim 4^\circ$ for free
- **Distance to target**
 - At 1 (1.2) km, need 54 (65) m deep pit to span 1° - 4°
 - Event pileup must be manageable (see later slides)
- **Tank diameter**
 - Determines maximum muon contained
 - 4 m (+ FV cut) for 1 GeV/c muon
 - PID degrades near the wall
 - Important for selecting e-like events
 - Larger = more stats, but also more pileup
 - Larger = more PMTs = more expensive
 - How much outer detector is necessary?

Off-axis Fluxes

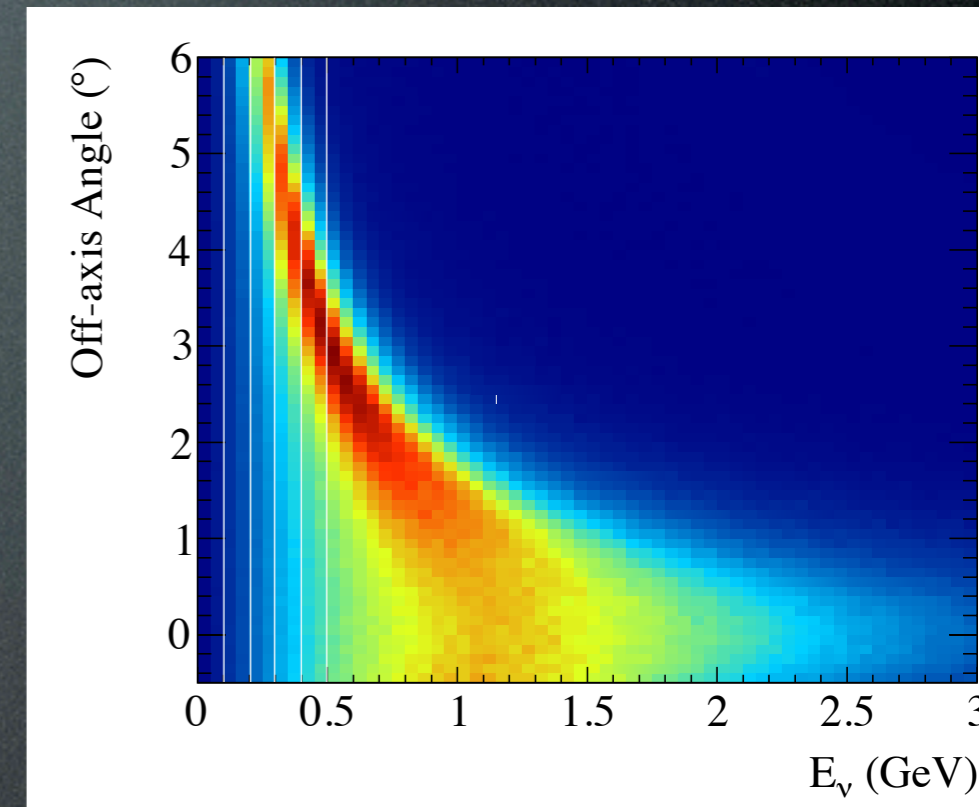

Muon Range

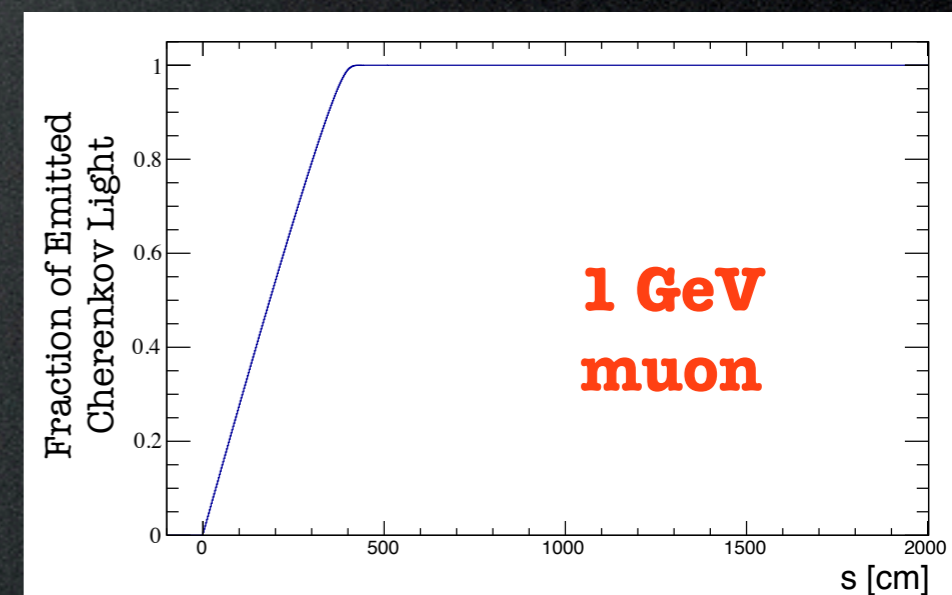

ν PRISM-Lite

- At 1 km, need 50 m tall tank to span 1-4° off-axis angle
- Instrument one subsection of the tank at a time with a moveable detector
- Baseline design:
 - Inner Detector (ID): 6m diameter, 10m tall
 - Outer Detector (OD): 10m diameter, 14m tall
- To improve sand muon tagging (precise entering position and time), OD is surrounded by scintillator panels

ID: 8" PMTs
(5" PMTs are also
being considered)

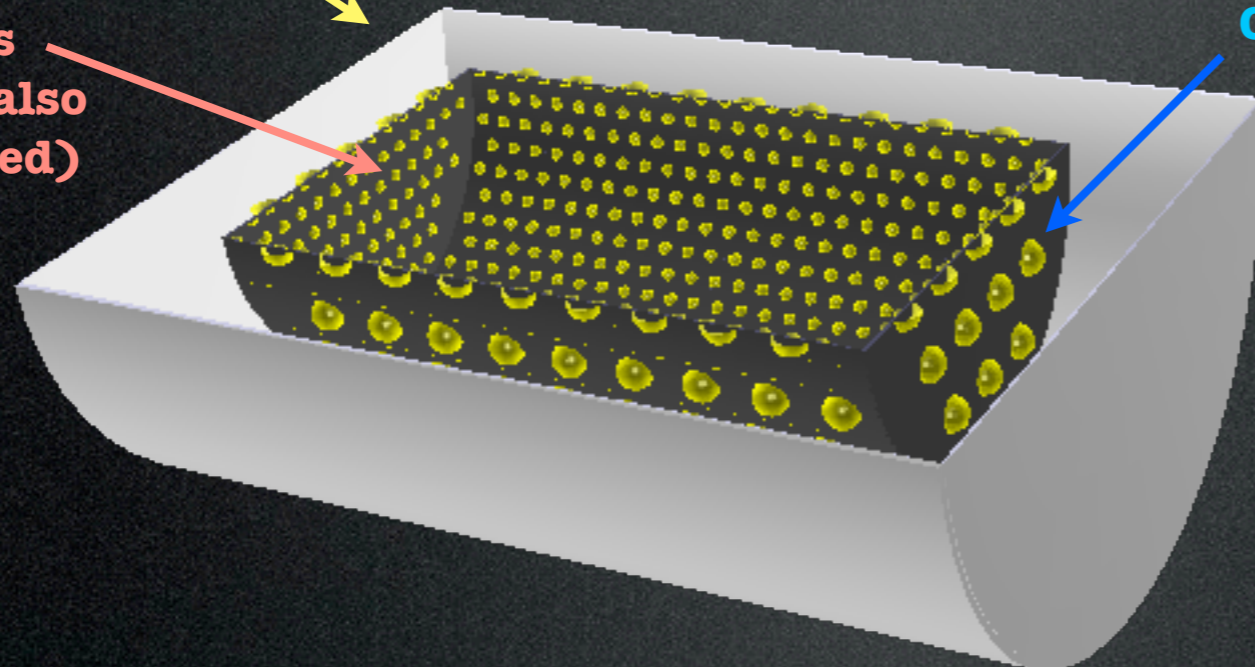

OD: 20" PMTs

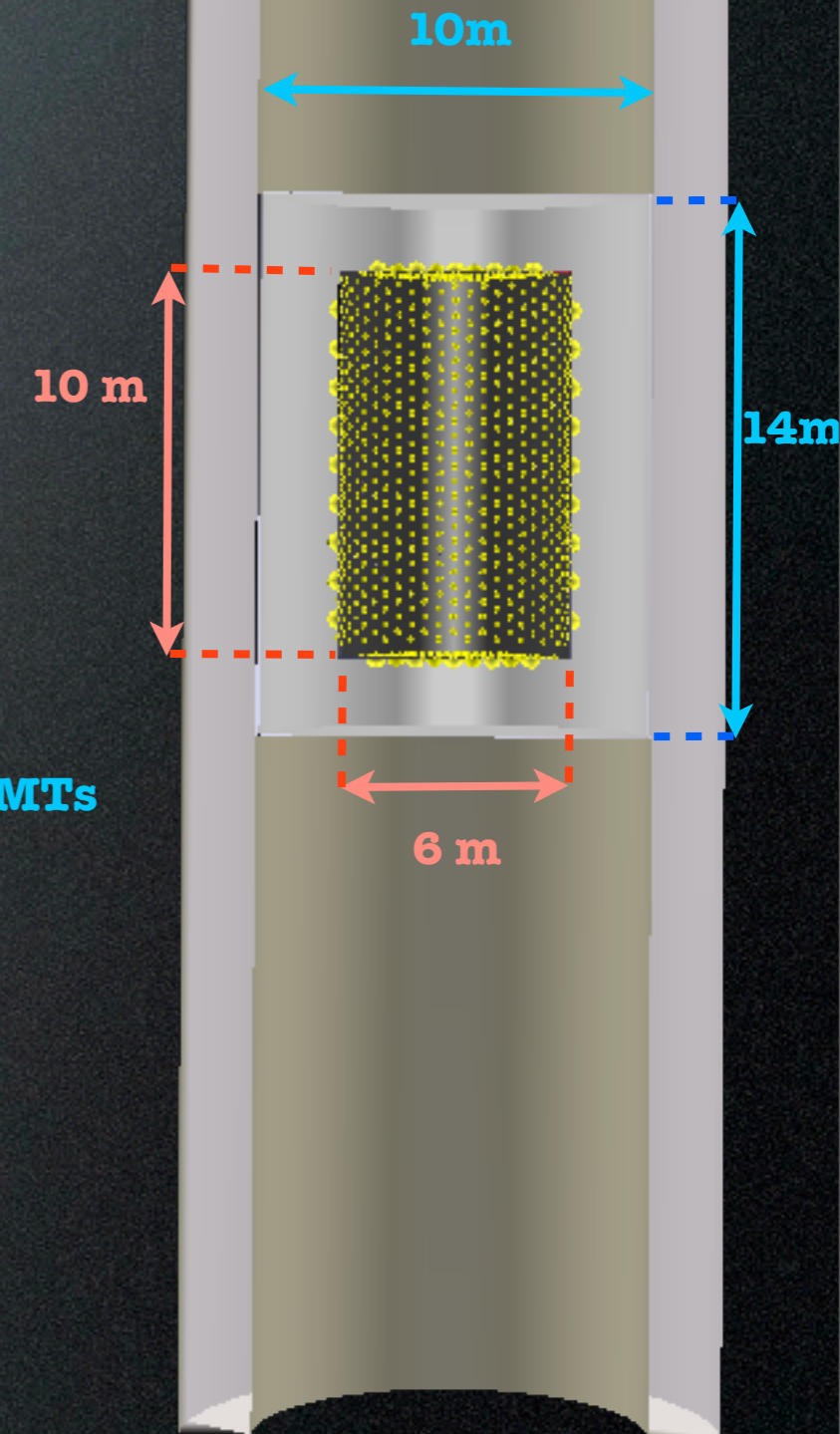

Event Pileup

- Full GEANT4 simulation of water and surrounding sand
 - Using T2K flux and neut cross section model
- 8 beam bunches per spill, separated by 670 ns with a width of 27 ns (FWHM)
- **41% chance of in-bunch OD activity during an ID-contained event**
 - Want to avoid vetoing only on OD light (i.e. using scintillator panels)
- **17% of bunches have ID activity from more than 1 interaction**
 - 10% of these have no OD activity
 - Need careful reconstruction studies
 - (but multi-ring reconstruction at Super-K works very well)

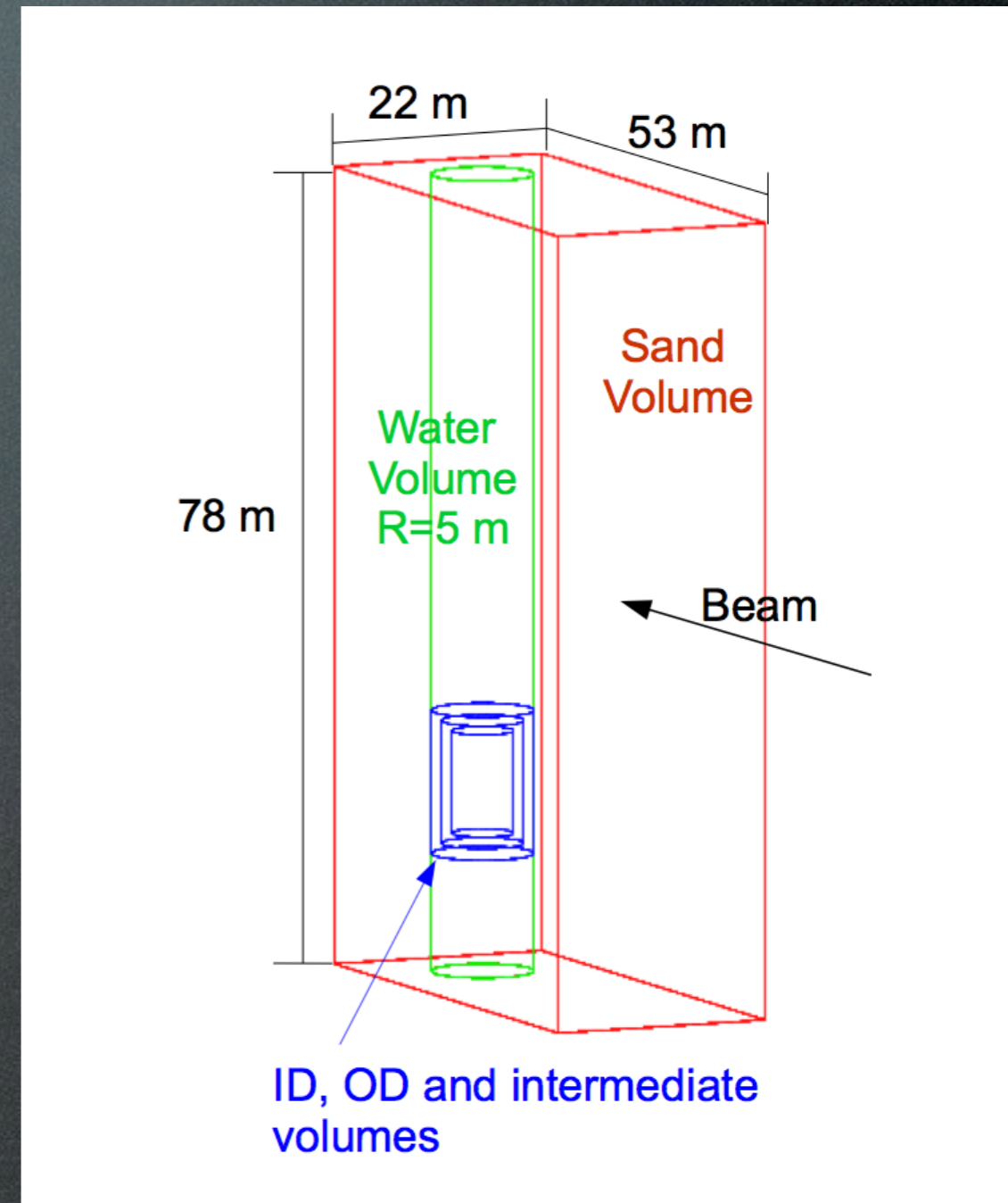

Pileup Rates at 1 km Look Acceptable!

Civil Construction

- Estimates have been acquired for various construction methods (see table below)
- Initial estimates are for a 50m deep, 10m diameter pit
 - Final options will depend on detailed geological survey performed at the chosen site
- Current estimates range from US \$5M to \$8M

Table 1: Summary of initial cost estimation for civil construction.

(Unit: Oku JPY, roughly corresponds to Million USD)

Method	Pneumatic Caisson	Soil Mixing Wall	New Austrian Tunneling	Urban Ring
Survey	0.1 (assume 70 m deep boring survey)			
Designing	0.15			
Land preparation	0.15			
Construction	7.7	5.9	5.3~6.1	7.5

Detector Frame

- Initial proposal for ID/OD frame and lifting mechanism has been produced
- Careful consideration given to water flow rate while in motion
- 4 towers allow the entire detector to be lifted out of the water tank for maintenance

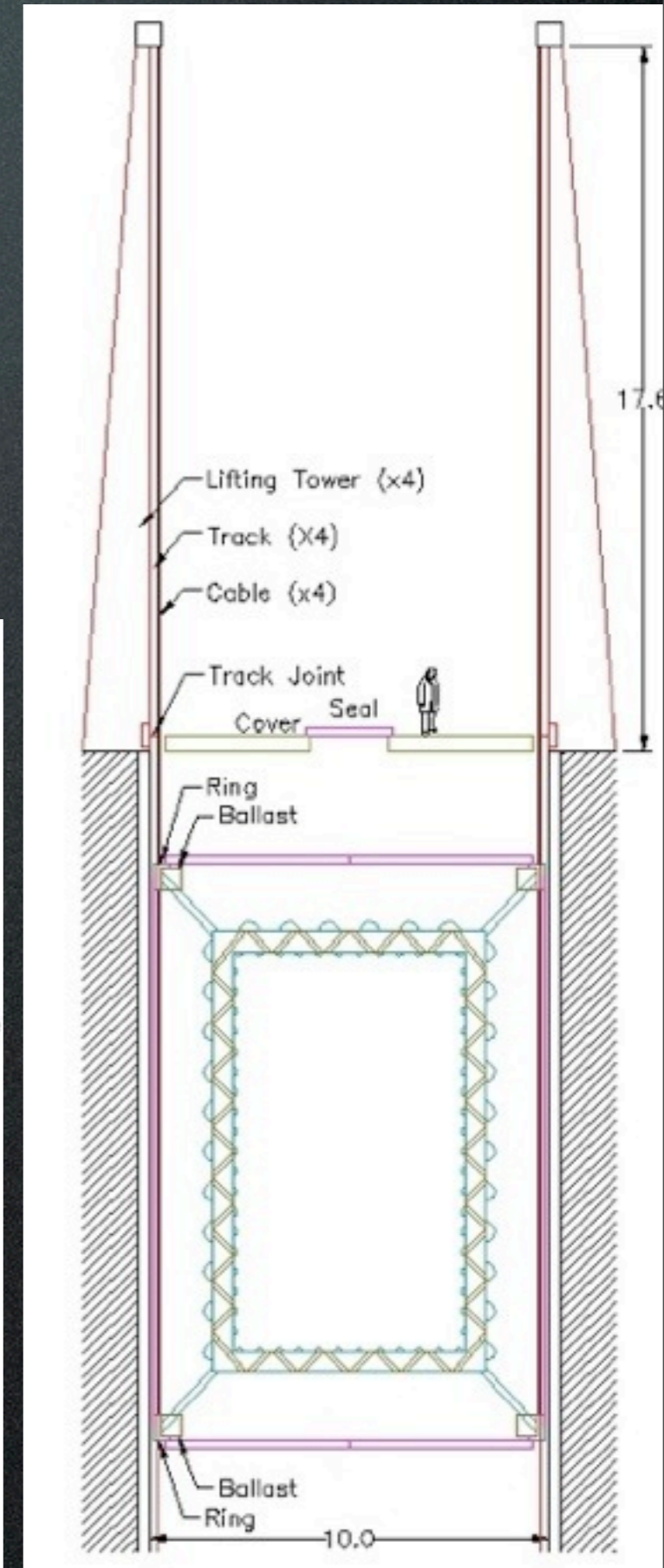
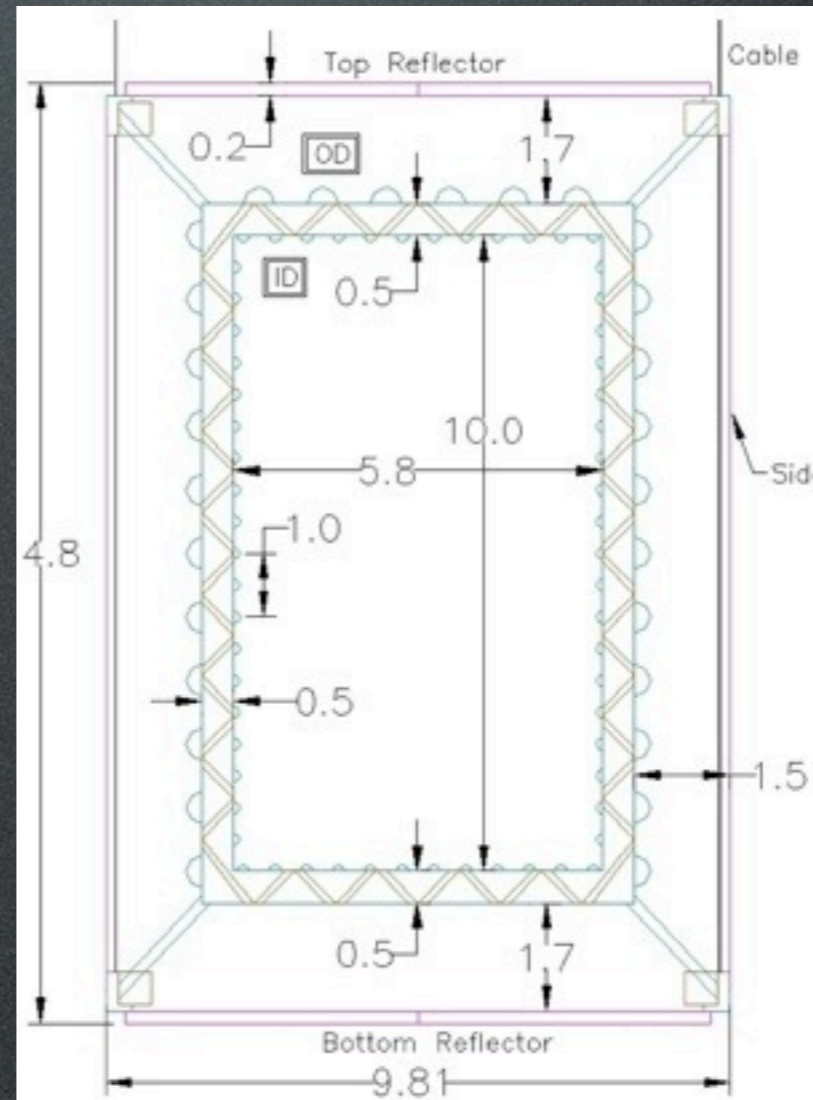
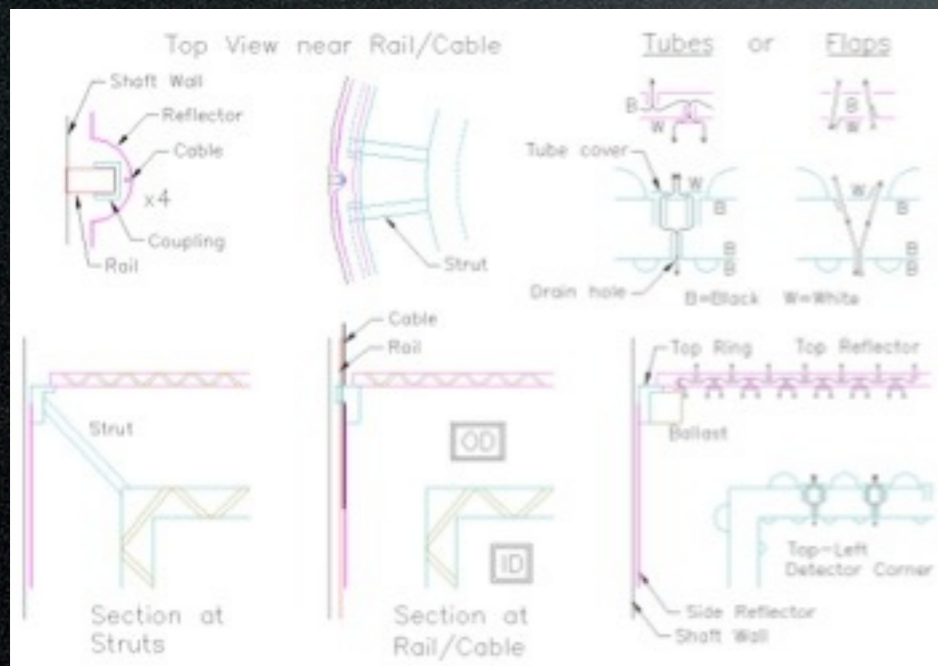

Top View

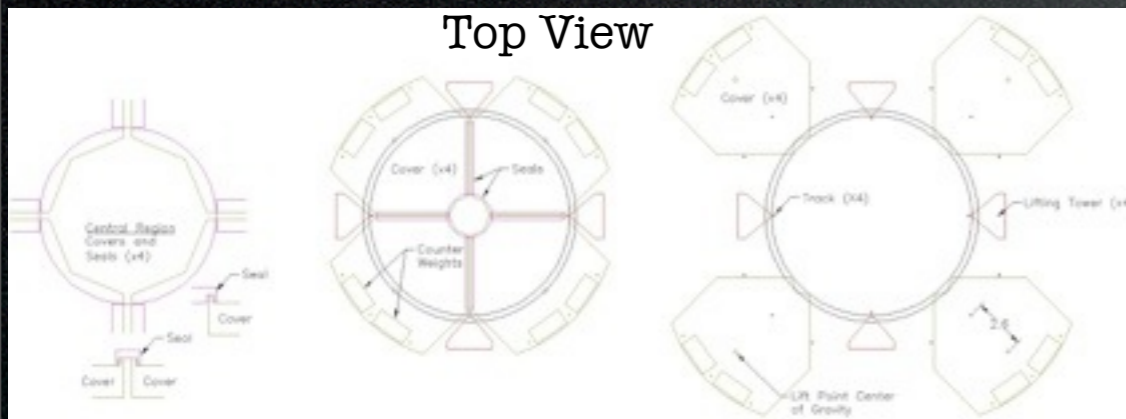

Timescales

- Water Cherenkov construction was studied for a T2K near detector proposed in 2005
- vPRISM construction time is faster
 - Same pit depth as the 2km detector, but no excavation of a large cavern at the bottom of the pit
 - Smaller instrumented volume
 - No LAr or MRD detector
- < 3 year timescale from approval to data taking
- Goal is to start data taking in time for the J-PARC 700kW beam upgrade expected in 2019
 - Ground breaking in 2016

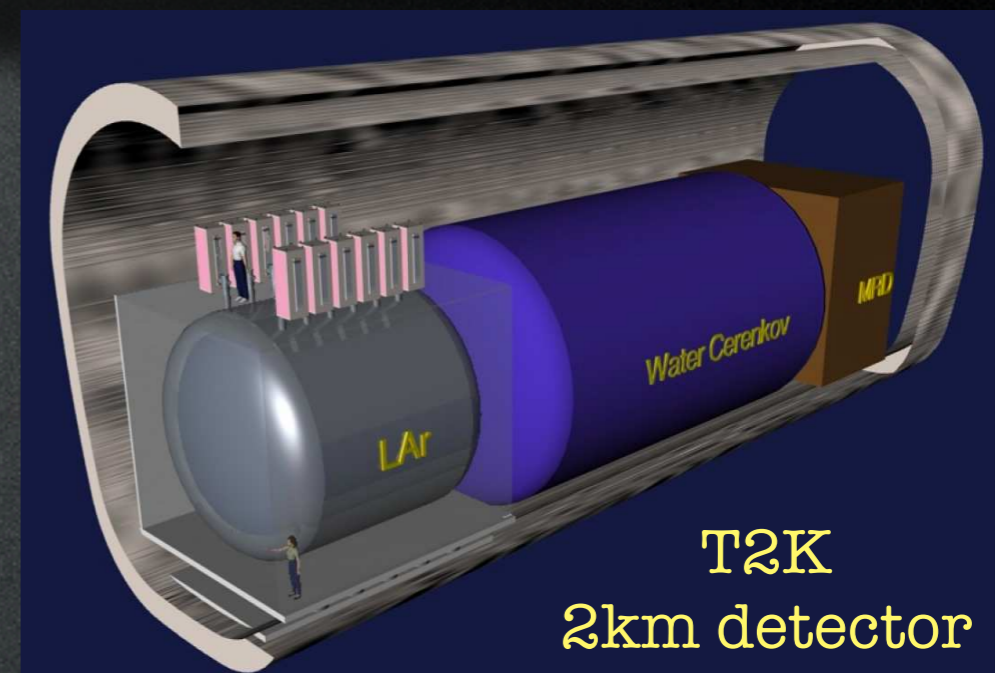
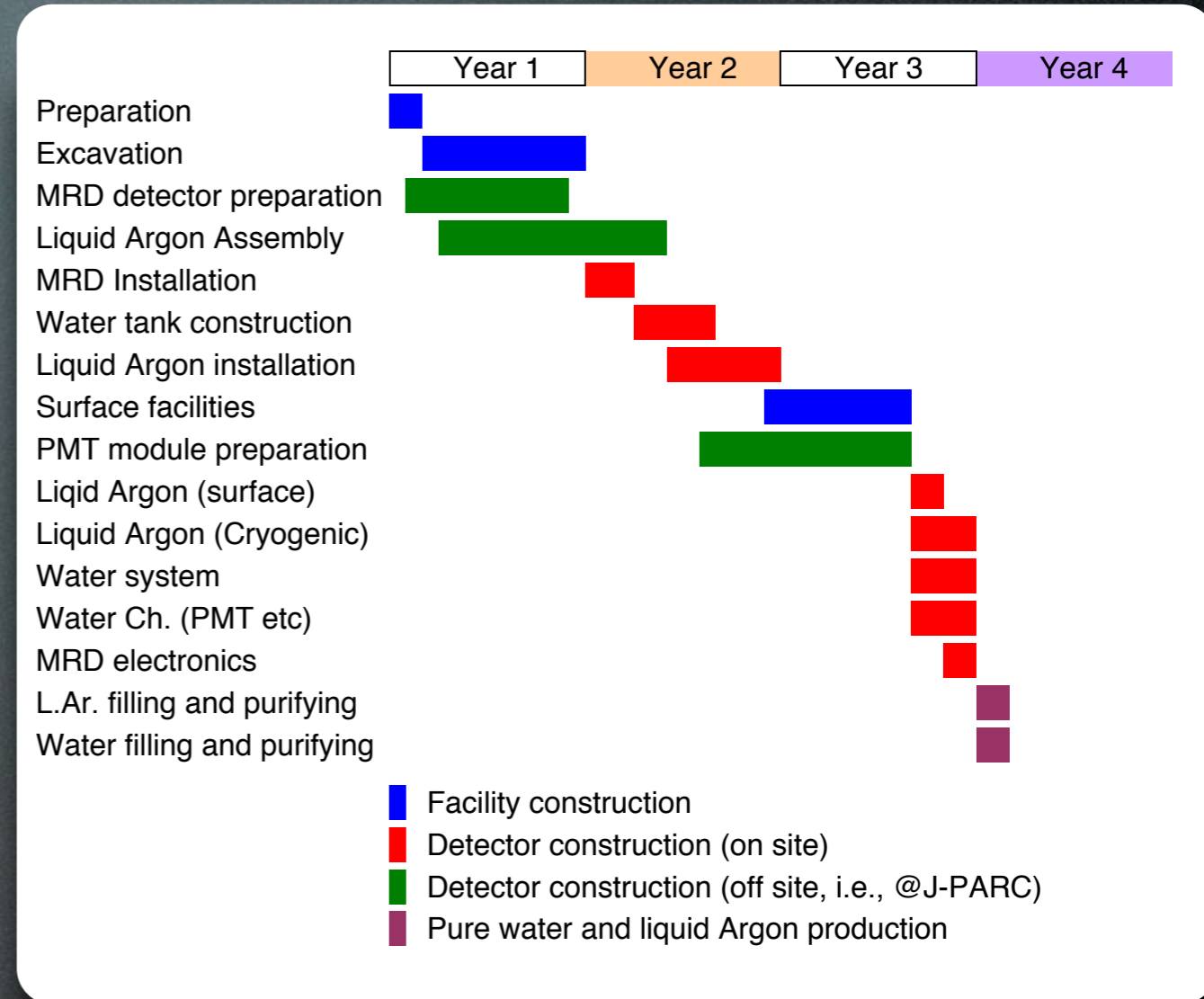

Current Status

- A Letter of Interest (LoI) was submitted to the J-PARC PAC in November 2014

- arXiv:1412.3086

- Several sources of money already exist to build a WC detector for Hyper-K R&D

- \$2M in Canada, \$2M in Japan, ...

- If timescales are compatible; this money can be used for nuPRISM

- nuPRISM provides a mechanism for new collaborations to participate in Japanese ν -physics

- Japanese bridge project between T2K and Hyper-K

- Analogous to Fermilab's LAr short-baseline program to prepare for LBNF

Letter of Intent to Construct a nuPRISM Detector in the J-PARC Neutrino Beamline

S. Bhadra,²⁴ A. Blondel,³ S. Bordini,⁵ A. Bravar,³ C. Bronner,⁹ J. Caravaca Rodríguez,⁵ M. Dziewiecki,²³ T. Feusels,¹ G.A. Fiorentini Aguirre,²⁴ M. Friend,^{4,*} L. Haegel,³ M. Hartz,^{8,22} R. Henderson,²² T. Ishida,^{4,*} M. Ishitsuka,²⁰ C.K. Jung,^{11,†} A.C. Kaboth,⁶ H. Kakuno,²⁵ H. Kamano,¹³ A. Konaka,²² Y. Kudenko,^{7,‡} M. Kuze,²⁰ T. Lindner,²² K. Mahn,¹⁰ J.F. Martin,²¹ J. Marzec,²³ K.S. McFarland,¹⁵ S. Nakayama,^{18,†} T. Nakaya,^{9,8} S. Nakamura,¹² Y. Nishimura,¹⁹ A. Rychter,²³ F. Sánchez,⁵ T. Sato,¹² M. Scott,²² T. Sekiguchi,^{4,*} M. Shiozawa,^{18,8} T. Sumiyoshi,²⁵ R. Tacik,^{14,22} H.K. Tanaka,^{18,†} H.A. Tanaka,^{1,§} S. Tobayama,¹ M. Vagins,^{8,2} J. Vo,⁵ D. Wark,¹⁶ M.O. Wascko,⁶ M.J. Wilking,¹¹ S. Yen,²² M. Yokoyama,^{17,†} and M. Ziemicki²³

(The nuPRISM Collaboration)

¹University of British Columbia, Department of Physics and Astronomy, Vancouver, British Columbia, Canada

²University of California, Irvine, Department of Physics and Astronomy, Irvine, California, U.S.A.

³University of Geneva, Section de Physique, DPNC, Geneva, Switzerland

⁴High Energy Accelerator Research Organization (KEK), Tsukuba, Ibaraki, Japan

⁵Institut de Física d'Altes Energies (IFAE), Bellaterra (Barcelona), Spain

⁶Imperial College London, Department of Physics, London, United Kingdom

⁷Institute for Nuclear Research of the Russian Academy of Sciences, Moscow, Russia

⁸Kavli Institute for the Physics and Mathematics of the Universe (WPI), Todai

Institutes for Advanced Study, University of Tokyo, Kashiwa, Chiba, Japan

⁹Kyoto University, Department of Physics, Kyoto, Japan

¹⁰Michigan State University, Department of Physics and Astronomy, East Lansing, Michigan, U.S.A.

¹¹State University of New York at Stony Brook, Department of Physics and Astronomy, Stony Brook, New York, U.S.A.

¹²Osaka University, Department of Physics, Osaka, Toyonaka, Japan

¹³Osaka University, Research Center for Nuclear Physics(RCNP), Ibaraki, Osaka, Japan

¹⁴University of Regina, Department of Physics, Regina, Saskatchewan, Canada

¹⁵University of Rochester, Department of Physics and Astronomy, Rochester, New York, U.S.A.

¹⁶STFC, Rutherford Appleton Laboratory, Harwell Oxford, and Daresbury Laboratory, Warrington, United Kingdom

¹⁷University of Tokyo, Department of Physics, Tokyo, Japan

¹⁸University of Tokyo, Institute for Cosmic Ray Research, Kamioka Observatory, Kamioka, Japan

¹⁹University of Tokyo, Institute for Cosmic Ray Research, Research Center for Cosmic Neutrinos, Kashiwa, Japan

²⁰Tokyo Institute of Technology, Department of Physics, Tokyo, Japan

²¹University of Toronto, Department of Physics, Toronto, Ontario, Canada

²²TRIUMF, Vancouver, British Columbia, Canada

²³Warsaw University of Technology, Institute of Radioelectronics, Warsaw, Poland

²⁴York University, Department of Physics and Astronomy, Toronto, Ontario, Canada

²⁵Tokyo Metropolitan University, Department of Physics, Tokyo, Japan

Next Steps

- **Need to extend LBL physics studies beyond ν_μ disappearance**
 - Complete ν_e appearance / CP violation sensitivity is underway
 - Including anti-neutrinos (w/ wrong-sign background)
- **Need to complete a realistic sterile neutrino sensitivity**
 - Current sensitivity is overly conservative
- **Detailed detector MC development is underway**
 - Much of this work has already been done for Hyper-K
 - Full MC and reconstruction software are available
- **More detailed design and engineering work is being pursued**
 - Detailed civil engineering will require support from J-PARC
 - Cost estimates for all detector components are underway
 - Many have been completed already

Summary

- Accelerator-based neutrino oscillation experiments require precision measurements of E_ν
 - Currently, must rely on complicated nuclear models to related E_ν to experimental observables
 - Models are rapidly evolving, and large disagreements exist between available models
- The ν PRISM detector concept can provide a direct, data-driven constraint on E_ν reconstruction
 - Far detector response is measured for any oscillated spectrum
- Hope to have a working example for T2K in 2019
- This concept can be useful for any accelerator-based neutrino experiment

