

**Fermi National Accelerator Laboratory**

**SVX II Silicon Upgrade**

**Silicon Readout Controller**

**-SRC Transition Module Board Design-  
*Preliminary Document***

20 February, 1998

Harvard University

Participants

J. Huth (PI)  
J. Oliver (Eng)  
N. Felt (Eng)  
S. Bailey (Grad student)  
M. Spiropulu (Grad student)  
C. Gay (Post doc)  
P. Maksimovic (Post doc)  
G. Novack (Undergrad)  
P. Batra (Undergrad)  
N. Scielzo (Undergrad)  
S. Harder (Tech)  
J. O’Kane (Tech)

<i>1. Introduction</i>	<i>1</i>
<i>2. Board design</i>	<i>1</i>
<i>3. Physical Description</i>	<i>6</i>
<i>4. Appendix</i>	<i>7</i>
<i>5. Table of Figures</i>	<i>12</i>

## 1. Introduction

This is a preliminary document. As the design progresses a more complete version will become available.

This document specifies the design of the Silicon Readout Controller Transition Module or SRCTM. The SRCTM is a 9U transition board whose purpose is to transmit commands and data from the SRC to the FIBs at a high rate and to receive FIB errors via a status return cable. To accomplish this the SRCTM uses the HP G-link chip and the Finisar fiber optic Transmitter. The Gigabit rate G-link chip acts as virtual ribbon cable interface. 20 bits of parallel data and commands from the SRC are serialized by the G-link then transmitted to the FIB Fanout through a optical fiber. Each FIB Fanout converts the serial data into parallel using the receiving versions of the same components.

## 2. Board design

The SRCTM contains Four G-link Optical Transmitters and four FIB Fanout status return cable connections as can be seen in Figure 2-1. SVX requires 4 FIB status return cables. ISL also requires 4 FIB status return. If the same SRC is to control the SVX and ISL the SRCTM would need to provide for 8 FIB Fanouts. This can be accomplished by optically splitting the four G-link fibers into eight. Also, the SRCTM will have connectors for an optional mezzanine card containing an additional four status return connectors. Each of the FIB status lines returned from different fibs will be ORed providing one set of status to the SRC. A block diagram of the SRCTM is given in Figure 2-1.

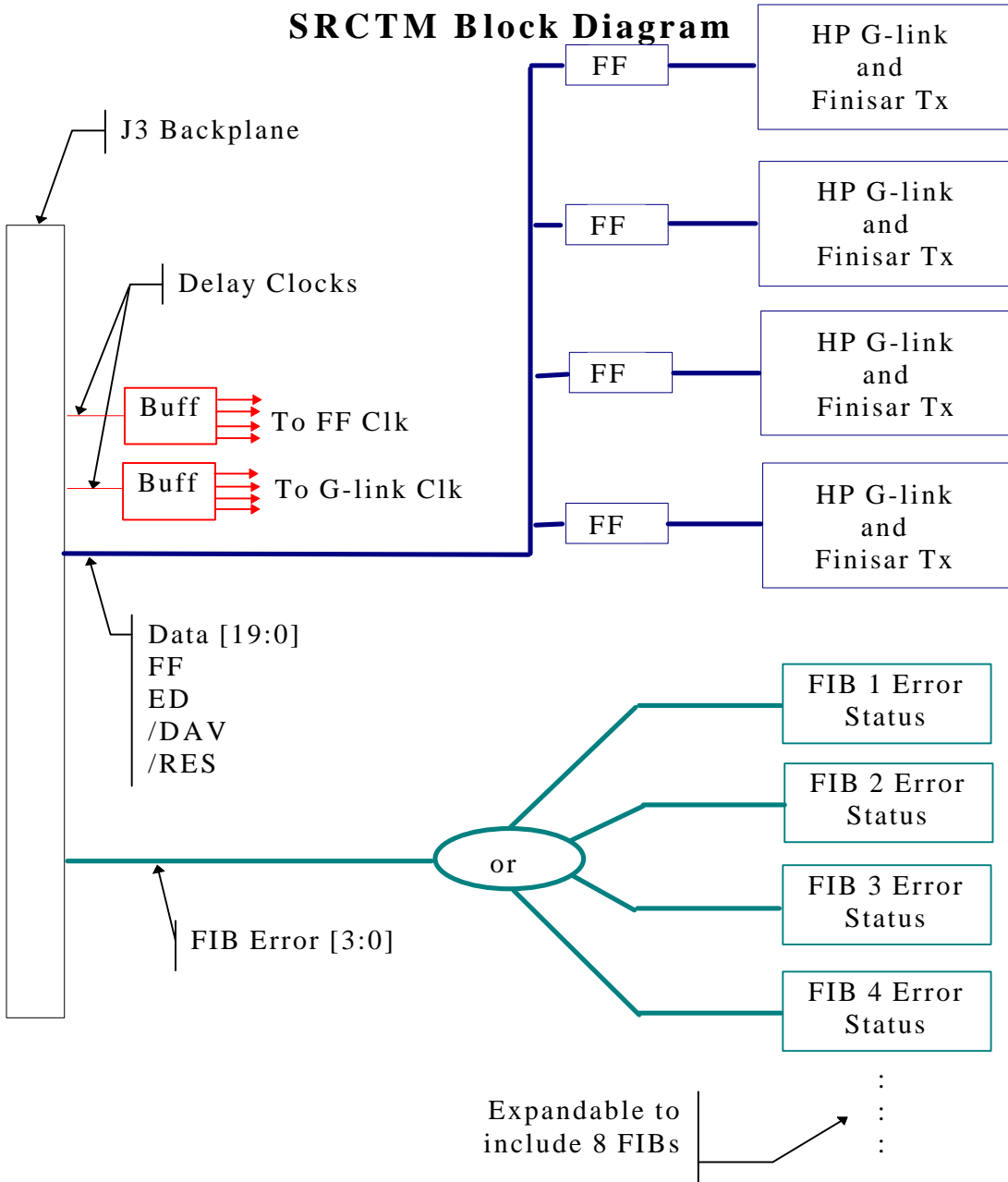

**Figure 2-1 - Block Diagram**

Figure 2-2 shows how G-link data enters the Board through the backplane from the SRC. Since all of the FIBs will get the same data, one set of data will travel along the board as a bus. The data is registered before going to the G-link circuits. The part chosen for the registers (CY74FCT2374) incorporates a series resistor to reduce reflection noise.

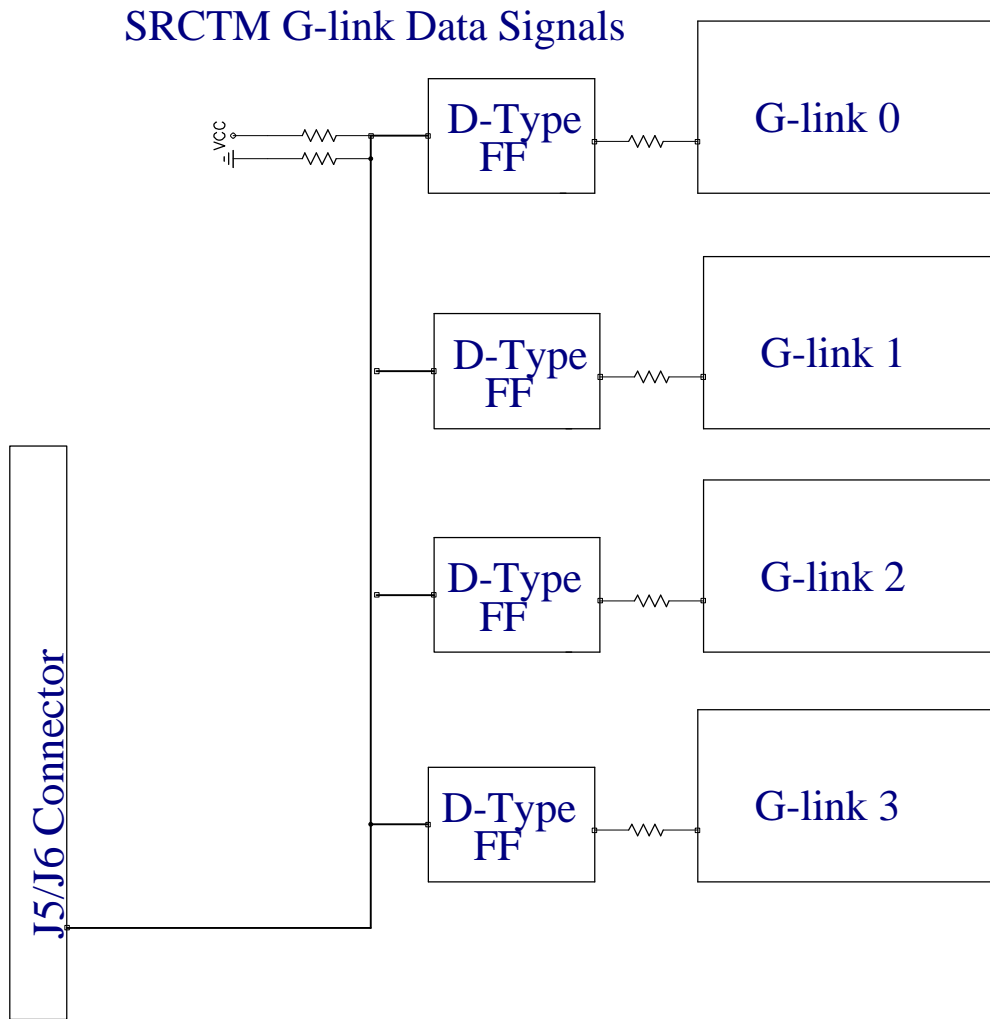

Figure 2-2 - Board Data Bus

The board requires two clocks, one for the G-links and one for the registers. These clocks are adjustable on the SRC. The clocks are split and buffered close to the connector as seen in Figure 2-3. The signals are terminated and buffered once more before the G-link and register clock input. The part chosen for the buffers (CY74FCT2244) incorporate a series resistor to reduce reflection noise.

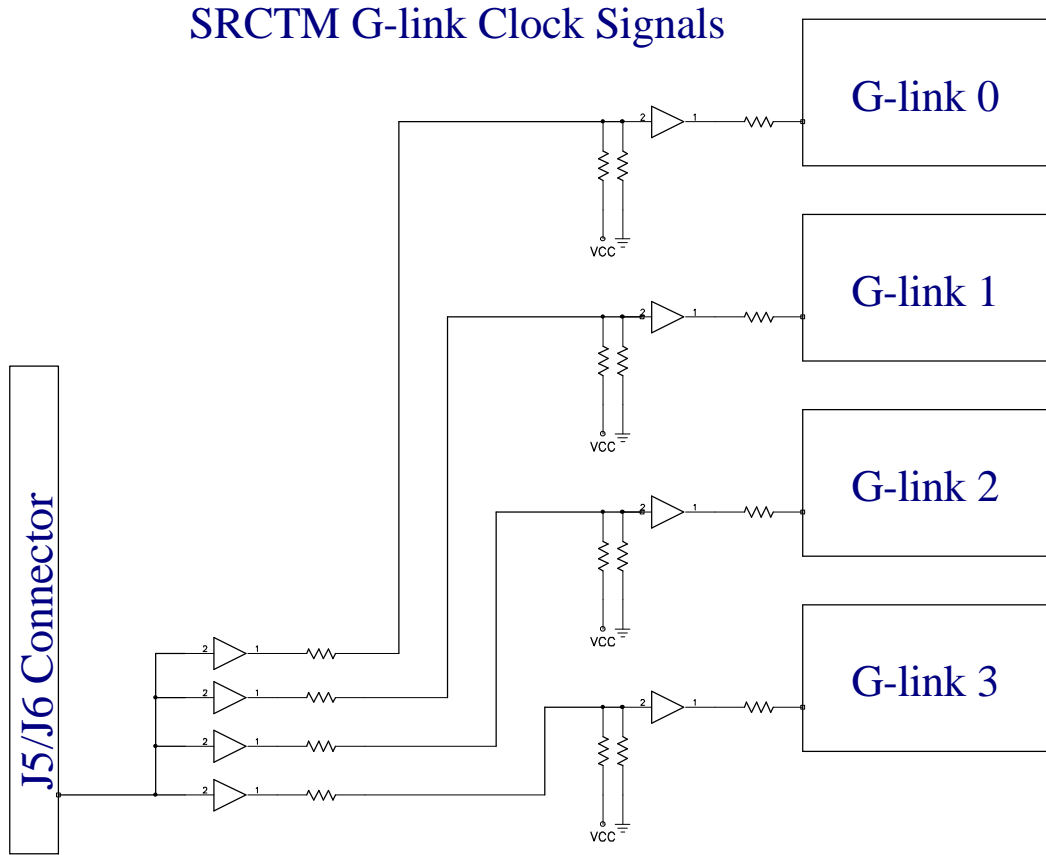
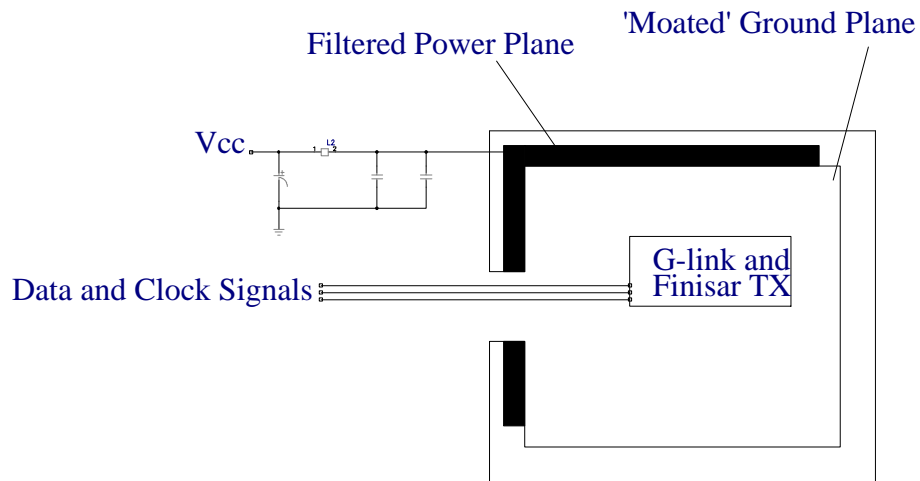

Figure 2-3 - Board Clocks

Each G-link and Finisar transmitter pair will have their own filtered power plane and moated ground plane shown in Figure 2-4. The data signals and clock will cross the Moat over the portion of the ground plane which is connected to the board plane.

SRCTM Power and Ground Planes



Every G-link and Finisar Optical Part will have a Filtered Power

Figure 2-4 - G-link Power and Ground

### **3. Physical Description**

The SRCTM is 366.7 mm tall, 120mm wide and .093 inch thick. The board has 6 layers, four layers are signal layers and two are power layers. The top and bottom signal micro strip layers will be 12 mills wide and have an impedance of 80 ohms.

#### 4. Appendix

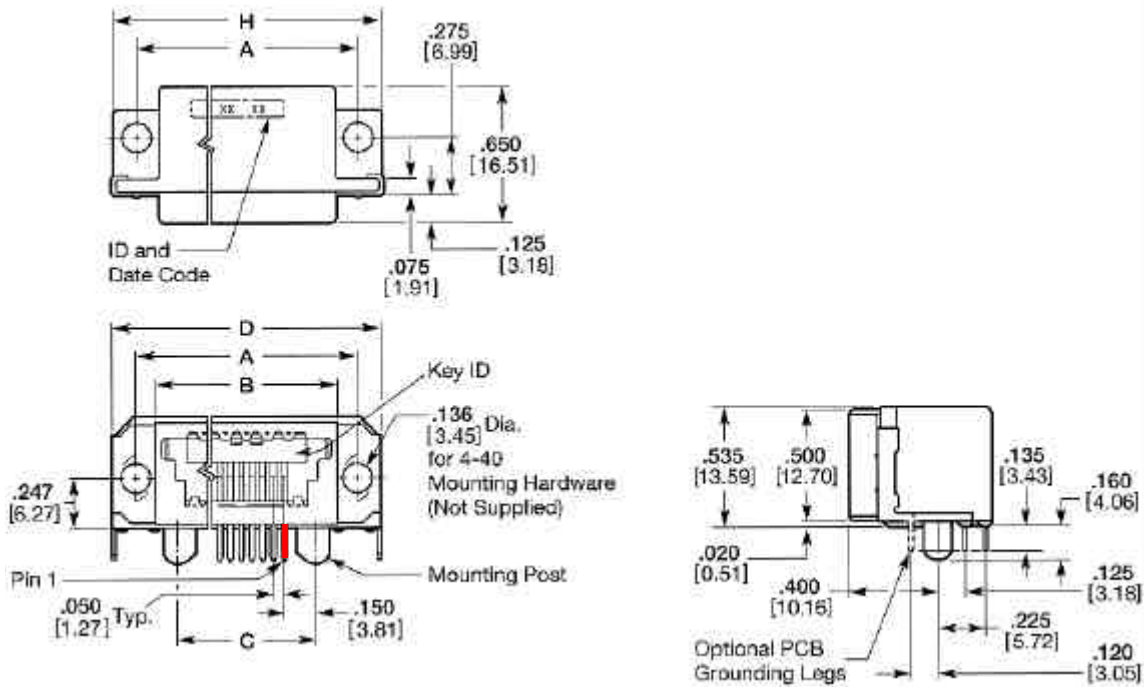

Figure 4-1 - FIB Status Return Cable Connector

Pin	Signal
1	FIB_ER0+
2	FIB_ER0-
3	FIB_ER1+
4	FIB_ER1-
5	FIB_ER2+
6	FIB_ER2-
7	FIB_ER3+
8	FIB_ER3-

Figure 4-2 - FIB Status Cable Pinouts

<b>Mezzanine Connector A</b>		<b>Mezzanine Connector B</b>	
Pin	Signal	Pin	Signal
1	FIB4_ER0+	1	FIB6_ER0+
2	FIB4_ER0-	2	FIB6_ER0-
3	FIB4_ER1+	3	FIB6_ER1+
4	FIB4_ER1-	4	FIB6_ER1-
5	FIB4_ER2+	5	FIB6_ER2+
6	FIB4_ER2-	6	FIB6_ER2-
7	FIB4_ER3+	7	FIB6_ER3+
8	FIB4_ER3-	8	FIB6_ER3-
9	FIB5_ER3-	9	FIB7_ER3-
10	FIB5_ER3+	10	FIB7_ER3+
11	FIB5_ER2-	11	FIB7_ER2-
12	FIB5_ER2+	12	FIB7_ER2+
13	FIB5_ER1-	13	FIB7_ER1-
14	FIB5_ER1+	14	FIB7_ER1+
15	FIB5_ER0-	15	FIB7_ER0-
16	FIB5_ER0+	16	FIB7_ER0+

**Figure 4-3 - Optional Mezzanine Connector for FIB 3-7**

Design		SRCTM			
		J3 Connector Connections			
Date	2/2/98 14:18				
Signal	I	O	OT	I/O	Function
GLD[19:0]	20				G-link Data (20 Bits)
FF					Fill Frame
/RES					Reset
/DAV					Data Valid
ED					Enable Data
/CAV					Command Valid (used to signal FFO RUN)
LOCK		1			G-link Transmitter Lock With RF_CLK
FIB_ERR[3:0]		4			FIB Fanout Error Return Line
/CS[3:0]	4				G-link Status chip select
SI					G-link Status Serial Command Input
SO		1			G-link Status Serial Data Output
READY		1			G-link Status Ready
SCLK					G-link Status Clock
GL_CLOCK					Phase Adjustable CDF 53MHz Clock
RF_DEL_CLK					Phase Adjustable CDF 53MHz Clock
<b>Pin Count</b>	<b>7</b>	<b>0</b>	<b>0</b>		<b>40</b>

Figure 4-4 - J5/J6 Signals

PIN	ROW A	ROW B	ROW C	ROW D	ROW E	ROW F
1	GND	FIB CLK	TTL0	FIB CLK	GND	GND
2	B_MCLK	FIB CLK	TTL1	FIB CLK	GND	GND
3	GND	FIB CLK	TTL2	FIB CLK	GND	GND
4	B_AD_PIPE	FIB CLK	TTL3	FIB CLK	GND	GND
5	GND	FIB CLK	TTL4	FIB CLK	GND	GND
6	B_SYNC	FIB CLK	TTL5	FIB CLK	GND	GND
7	GND	FIB CLK	TTL6	FIB CLK	GND	GND
8	GND	FIB CLK	TTL7	FIB CLK	GND	GND
9	GND	FIB CLK	TTL8	FIB CLK	GND	GND
10	GND	FIB CLK	TTL9	FIB CLK	GND	GND
11	GND	FIB CLK	TTL10	FIB CLK	GND	GND
12	GND	FIB CLK	TTL11	FIB CLK	GND	GND
13	GND	FIB CLK	TTL12	FIB CLK	GND	GND
14	RF_DEL_CLK	FIB CLK	TTL13	FIB CLK	GND	GND
15	GND	FIB CLK	TTL14	FIB CLK	GND	GND
16	GL_CLK	FIB CLK	TTL15	FIB CLK	GND	GND
17	GND	FIB CLK	TTL16	FIB CLK	GND	GND
18	C0	FIB CLK	TTL17	FIB CLK	GND	GND
19	RESET	FIB CLK	TTL18	FIB CLK	GND	GND
20	C1	FIB CLK	TTL19	FIB CLK	GND	GND
21	FF	FIB CLK	TTL20	FIB CLK	GND	GND
22	C2	FIB CLK	TTL21	FIB CLK	GND	GND
23	GND	FIB CLK	TTL22	FIB CLK	GND	GND
24	C3	FIB CLK	TTL23	FIB CLK	GND	GND
25	GND	GND	TTL24	GND	GND	GND
26	C4	READY	GND	GND	/CS0	GND
27	S1	SCLK	GND	/CS2	/CS1	GND
28	C5	S0	GND	/CS3	GND	GND
29	GND	GND	GND	GND	/CAV	GND
30	L_1/0	GND	GND	GND	GND	GND
31	GND	FIB_ERR0	GND	ED	GND	GND
32	C_CLK1	FIB_ERR1	N/C	/DAV	LOCK	GND
33	GND	FIB_ERR2	GND	GND	GND	GND
34	C_CLK2	FIB_ERR3	GND	GND	GND	GND
35	GLD18	GND	GND	GND	GLD19	GND
36	PIPE_RD2	GLD16	GND	GLD17	GND	GND
37	GND	GND	GND	GND	GND	GND
38	L1A	GLD14	GND	GLD15	GND	GND
39	GLD12	GND	GND	GND	GLD13	GND
40	FE_CLK1	GLD10	GND	GLD11	GND	GND
41	GND	GND	GND	GND	GND	GND
42	FE_CLK2	GLD8	GND	GLD9	GND	GND
43	GLD6	GND	GND	GND	GLD7	GND
44	BE_CLK1	GLD4	GND	GLD5	GND	GND
45	GND	GND	GND	GND	GND	GND
46	BE_CLK2	GLD2	GND	GLD3	GND	GND
47	GLD0	GND	GND	GND	GLD1	GND

REVISED LAYOUT for use with FFO and SRC and DEM

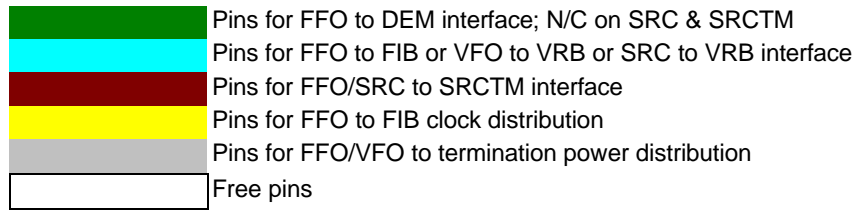

**Figure 4-5 - J5/J6 Connector Pinouts**

## 5. Table of Figures

<i>Figure 2-1 - Block Diagram</i>	2
<i>Figure 2-2 - Board Data Bus</i>	3
<i>Figure 2-3 - Board Clocks</i>	4
<i>Figure 2-4 - G-link Power and Ground</i>	5
<i>Figure 4-1 - FIB Status Return Cable Connector</i>	7
<i>Figure 4-2 - FIB Status Cable Pinouts</i>	7
<i>Figure 4-3 - Optional Mezzanine Connector for FIB 3-7</i>	8
<i>Figure 4-4 - J5/J6 Signals</i>	9
<i>Figure 4-5 - J5/J6 Connector Pinouts</i>	11