

# Noise Characterization of the ATLAS Tile Calorimeter Readout System

Christopher J. Meyer  
University of Chicago, Illinois, USA

April 29, 2009

## Abstract

It is shown that the addition of a bootstrap filter to the current ATLAS Tile Calorimeter 3in1 card increases s/n from 1500 to 1730. When a 12-bit ADC is used in place of the current 10-bit ADC s/n decreases from 1600 to 1500, but with the addition of the bootstrap filter s/n is brought back to an acceptable 1600.

## 1 Introduction

The Large Hadron Collider (LHC) is a circular proton-proton (pp) accelerator capable of reaching center-of-mass energies of 14 trillion electron volts (TeV) at the CERN facilities in Geneva, Switzerland. Planned to begin operation in late 2009 it has a designed initial luminosity of  $10^{27} \text{ cm}^{-2}\text{s}^{-1}$  which corresponds to bunches of  $10^{11}$  protons crossing 40 million times per second (40 MHz).

The data generated by these collisions will be read out by two general purpose detectors, ATLAS (A Toroidal LHC ApparatuS) and CMS (Compact Muon Solenoid). CMS will not be discussed in this paper. ATLAS is a forward-backward symmetric detector composed of three main systems: the inner detector, the calorimetry system, and the muon spectrometer.

The inner detector is composed of high-resolution semiconductor pixel and strip detectors in the inner part of the volume and straw-tube tracking detectors in the outer part. It is permeated by a 2 T solenoid field which bends particles for the purpose of momentum measurements. Its design goals are pattern recognition, momentum and vertex measurements, and electron identification.

The calorimetry system consists of two main sections, the liquid-argon (LAr) calorimeter and the hadron (tile) calorimeter. The calorimeters provide position and energy information on the particles they absorb (almost everything except muons and neutrinos). The LAr calorimeter is responsible for electrons and photons while the tile calorimeter provides information about hadrons (bound quark states).

The muon spectrometer is a light and open structure with three layers of high precision tracking chambers. Immersed in a magnetic field the muons are bent providing excellent momentum resolution. More information regarding the ATLAS detector can be found in Ref. [1].

This paper deals with the readout system for the tile calorimeter, particularly with the processing of the calorimeter output before it is digitized and outputted into a computer readable format.

## 2 ATLAS Tile Calorimeter Readout System

The current readout system for the ATLAS Tile Calorimeter consists of a number of 1.4 m long aluminum units called drawers. These drawers house the PMTs and readout electronics which take analog signals from the calorimeter and convert them into serialized digital output. This output is processed and written into data files which are later processed offline. Each drawer is connected to forty-eight PMTs, each of which is connected to a dedicated 3-in-1 card.

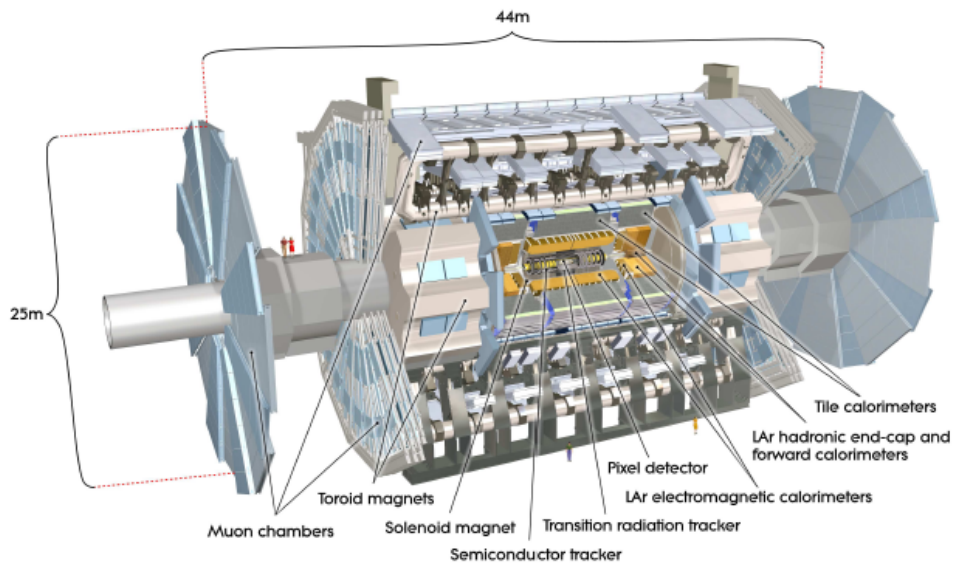

Figure 1: ATLAS detector.

The 3-in-1 card takes a PMT signal and (1) passes it through a seven-pole shaper consisting of passive elements, (2) sends it through a hi- and low-gain amplifier, (3) converts the signal into differential form to cut out baseline noise before sending the signal onward.

The clean, shaped analog curve is then converted into a digital signal by sampling at twenty-five nanosecond intervals. This analog-to-digital conversion (ADC) is done on a chip which buffers the input from six 3in1 cards. There are eight total ADCs to cover the forty-eight PMTs all of which hook into a single read out card responsible for the entire drawer.

In order to cover the wide range of energy deposits the calorimeter will face during operation 16 bits of dynamic range is needed. Due to practical limitations a 16-bit ADC is not feasible so the current Tile Calorimeter readout system uses a bigain 10-bit ADC instead. For the proposed Super LHC (sLHC) upgrade there is an effort to replace the 10-bit ADCs with 12-bit ADCs to account for general improvement in circuit technology and the higher luminosities expected.

The points mentioned above are described below in more detail.

### Tile Calorimeter

The tile calorimeter is made up of alternating layers of steel and plastic scintillator material in the layout shown in figure 2. The plastic scintillator (active medium) absorbs the energy of incident charged particles and then reemits it in the form of photons. In order to absorb all the hadrons traveling through the tile calorimeter the scintillator would have to be impractically large, so layers of steel are interspersed (called passive layers). The steel layers are much denser so undergo many more strong interactions with the hadrons travelling through them increasing the total radial thickness to 7.4 radiation lengths. These multiple interactions create showers of charged particles, some of which are detected by the scintillator. Since all the energy is not detected it is necessary to rescale the energy at a later time depending on what was travelling through the calorimeter (proton, pion, etc...). More specifics can be found in Ref. [1].

Fiberoptics then take the light from the scintillator and transports it to one of the forty-eight PMT tubes associated with the drawer. The light is then amplified through the PMT and outputed to the 3-in-1 card. The system is designed for a maximal pulse deposited in any give tile of 2 TeV [2].

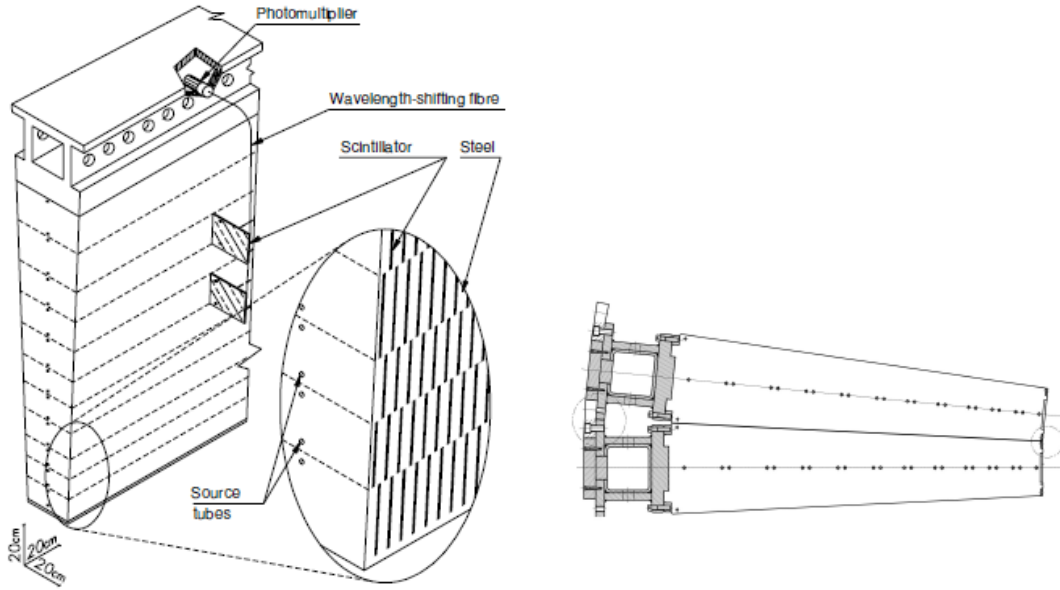

Figure 2: The left shows the arrangement of a slice of the tile calorimeter. 64 of these are arranged to create full cylindrical coverage. The right shows the azimuthal view of how two segments will fit together.

### 3in1 Card

The pulse coming out of the PMT generally has a 5.5 ns rise time and 11 ns fall time with jagged edges due to photo-electron effects[3]. The 3in1 card cleans up this signal into something the ADC can easily characterize. Since the ADC samples at 40 MHz (every 25 ns), the smallest signal which can be accurately sampled and later reconstructed must be no larger than 20 MHz. This corresponds to 50 ns, which is the width the shaped pulse is set to.

The shaping is done by a 7 pole, passive element shaper so as to reduce noise. It is based on a Bessel filter with bandwidth at -3dB of 12Mhz and has an effective noise bandwidth of 115%. Outputs for two gain ranges of 1V/800pC and 2V/800pC are provided. An example of the shaped pulse can be seen in figure 3.

While the upper limit on a pulse is 2 TeV corresponding to large showers, 30 MeV is the lower limit and corresponds to muons. The dynamic range required to accurately sample this range is then  $2\text{TeV}/30\text{MeV} = 2^{16}$ , so a 16-bit ADC is required. A 16-bit ADC is impractical because of noise and cost, so instead a 10-bit ADC bigain system with relative gain of 64 ( $2^6$ ) is employed. The high gain channel uses a CLC501 gain-of-16 clamping amplifier on the 2V/800pC output, while the low gain channel uses a CLC502 unity gain clamping amplifier on the 1V/800pC output provided by the shaper.

The third stage is to switch the signal to differential mode before outputting to the ADC since it is approximately a foot away in the experimental setup. In this way any noise picked up during transport will be cancelled out at the other end when it is removed from differential mode. The low-gain is put through a gain-of-1/2 differential driver while the high-gain channel is put through a differential driver of gain unity. More information can be found in Ref. [2]. A summary of this process is shown in the flow chart in figure 4.

## 2.1 Local Test Setup

The setup used for this study is a simpler version of the above. It consists of two 3in1 cards feeding into one ADC which is connected to a readout card communicating via ethernet with a computer control system.

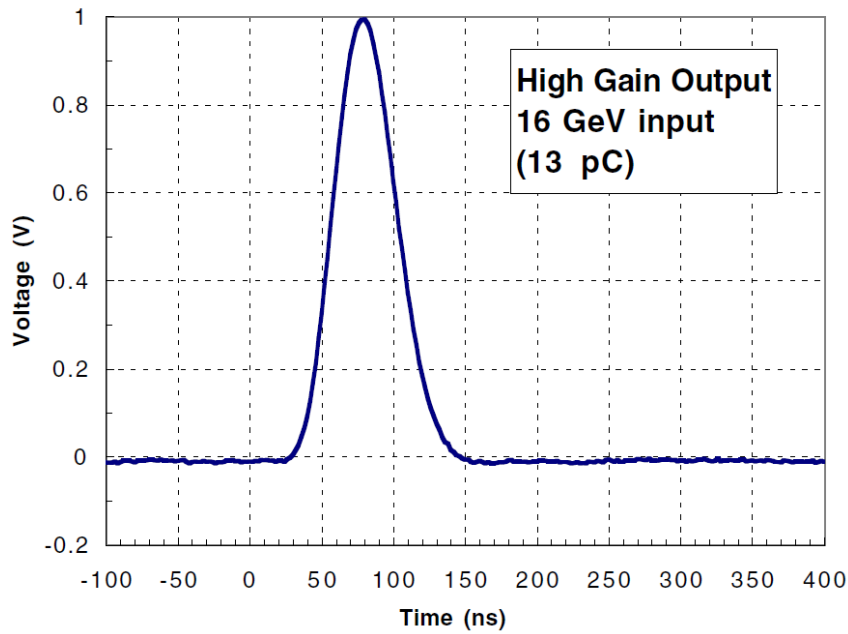

Figure 3: An example of the shaped pulse from the 3in1 card.

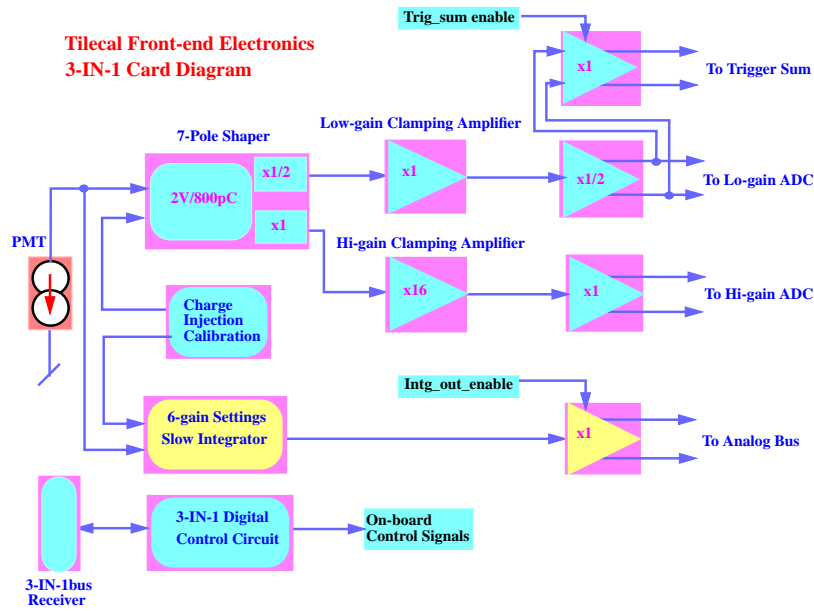

Figure 4: Flow chart of the 3-in-1 card.

Known pulses can be injected into the system (simulating PMT pulses) which are compared with the output of the test system. These pulses correspond to 1V for every 400nC of charge.

With this smaller setup the links between sub-systems can be opened up or even entirely replaced, enabling simple studies of various changes to the design. For this paper this includes the placement of a passive filter between the lo gain amplifier and differential section of the 3in1 card, as well as replacing the 10-bit with a 12-bit ADC and characterizing the differences in system noise. A schematic of the 3in1 card with proposed points of study is shown in figure 5.

## 2.2 DAQ and Analysis Routines

Data are logged using a lynx (unix like) environment by connecting to a VME crate controller which interfaces with the test setup. The shaped pulses for the two 3in1 cards are converted into binned histograms and stored in an array. All further analysis of the system is done using these binned pulses.

To determine the noise level the peak height above base line is computed by taking the peak voltage and subtracting the pedestal voltage

$$\Delta V = V_{peak} - V_{ped}.$$

The spread of  $\Delta V$  gives a good measure of the relative noise for different filters. This method is also used to compare the s/n ratio of 10-bit vs 12-bit ADC readout systems.

Before  $\Delta V$  can be calculated the timing needs to be set so one of the 5 ADC points (and thus one bin of the pulse) lands on the peak of the shaped signal. This is necessary because when computing  $V_{peak}$  the largest point is taken as the peak without performing a fit. The optimal timing is found by varying the offset between 0 and 240 ns and looking for a maximum amplitude. A plot of  $\Delta V$  vs time is given in figure 6. For both cards the optimal time is approximately 170 ns.

Once the optimal timing has been set a baseline for the noise can be found. Figure 7 shows the histograms of  $\Delta V$  for the original system setup. These will serve as baselines for later studies on alterations to the two boards.

## 3 Additional Filter Stage for 3in1 Card

### 3.1 Modifications

The first modification is to replace the old differential mode output driver consisting of 4 op-ams with two dedicated differential driver elements. This has already been decided on for the sLHC upgrade so it is a simple matter of replacing the old elements in the simulation schematics and bypassing the old elements when working directly with the board.

### 3.2 Results

## 4 Noise of 12-bit versus 10-bit ADC

### 4.1 Modifications

### 4.2 Results

## 5 Conclusion

As shown in figure 10 by bootstrapping the the output of the amplifier to the input signal the s/n ratio is increased from 1600 to 1730. In addition, moving to a 12-bit ADC increases the noise level of the system, but with the filter in place the s/n ratio returns to above 1600, the necessary level for muon detection.

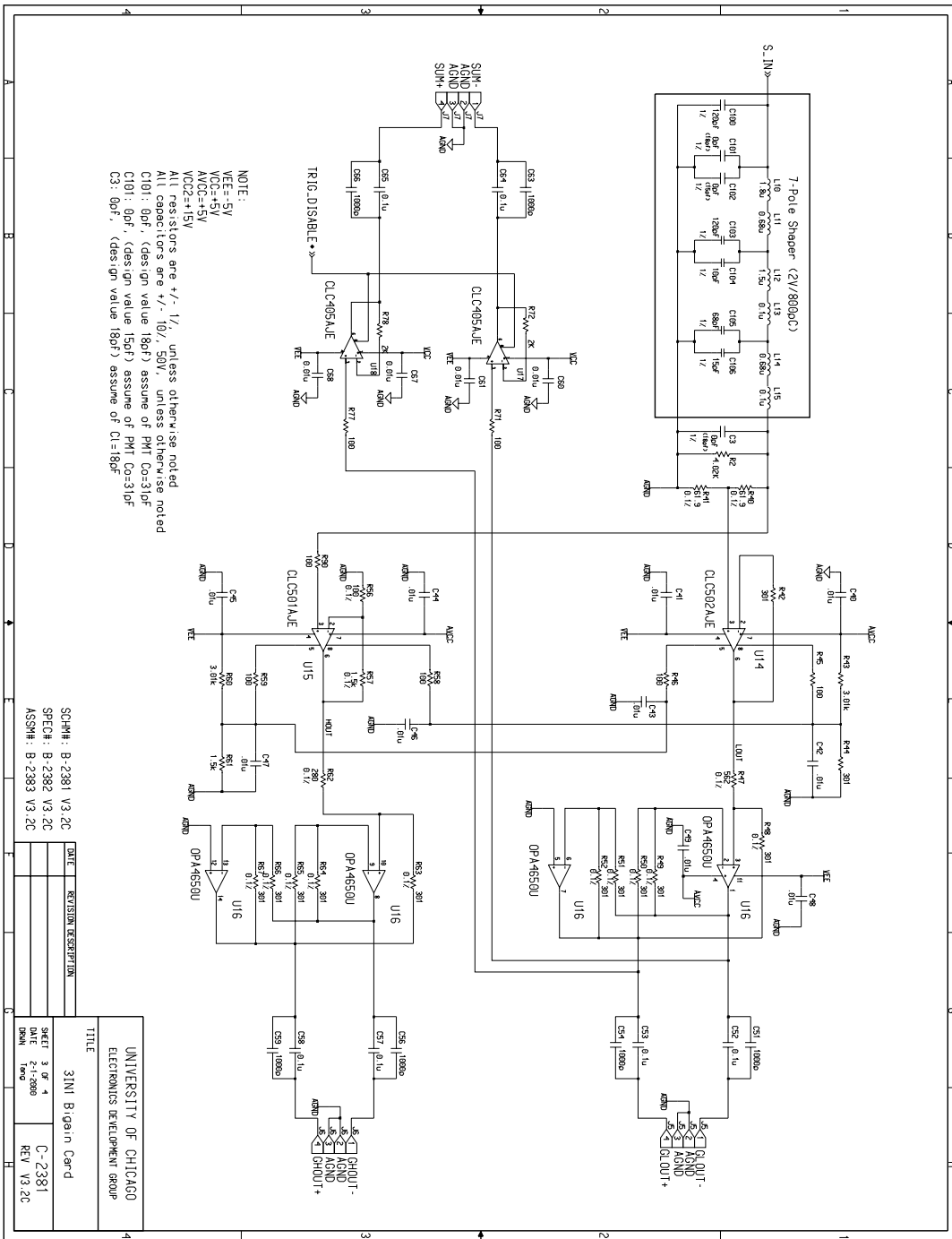

Figure 5: Schematic of 3 in 1 card. This will have boxes and arrows indicating sections to be studied.

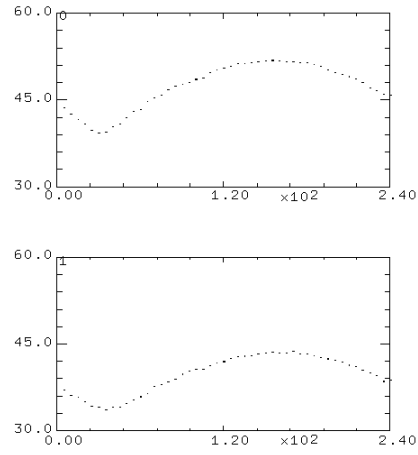

Figure 6: Timing offset vs peak voltage. The place where the “hump” is largest is the optimal timing offset. This will have lines at that value and labels of axis/title.

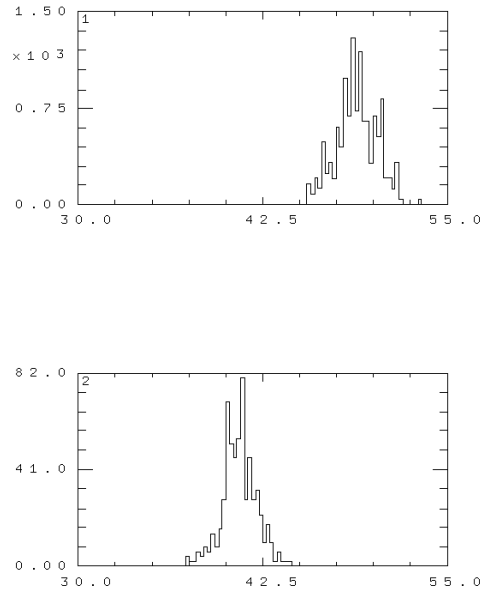

Figure 7: The baseline noise of the system. This will have the sigma and labels on the axis/title.



Figure 8: Schematic of filter with associated effect on noise. Several of these will be shown for the different filters tried.



Figure 9: Noise Diagram, 10-bit vs 12-bit ADC.



Figure 10: Noise of 12-bit ADC with filter in place.

## Acknowledgments

Thanks to Mark Oreglia for advising and providing all around support, Kelby Anderson for his expertise on the DAQ system, and Fukun Tang for advice concerning the circuit and its simulation in Mentor Graphics.

## References

- [1] ATLAS Collaboration, JINST 3 **S08003** (2008)
- [2] Anderson, K. et al., Front-end Electronics for the ATLAS Tile Calorimeter (1998)
- [3] The Tilecal Group, ATLAS TileCal Front End Electronics sLHC Upgrade Environment (2009)